

## Ultra Low Quiescent Current Linear Regulator

**UM153xxS SOT23-3**

**UM153xxY SOT89-3**

### General Description

The UM153xx series are ultra low quiescent current low dropout linear regulators designed for low power portable applications. The range of output voltage is from 1.3V to 5.0V while operated from 2.2V to 5.5V input.

The UM153xx series offer high output voltage accuracy, excellent transient response, stability with ultra low ESR ceramic capacitors as small as 1 $\mu$ F, thermal overload protection and output current limiting. The device is available in a low profile SOT23-3 or SOT89-3 package.

### Applications

- Battery-Powered Systems
- Reference voltage sources
- Cameras, Video cameras
- Portable AV systems
- Portable games
- Cellular Phones

### Features

- Maximum Input Voltage: 5.5V
- $\pm 2.0\%$  Voltage Accuracy at 30mA
- Fast Transient Response
- Output Current Limit
- Stable with 1 $\mu$ F Output Capacitor
- Thermal Overload Protection
- Low Profile SOT23-3 or SOT89-3 Package

### Pin Configurations

### Top View

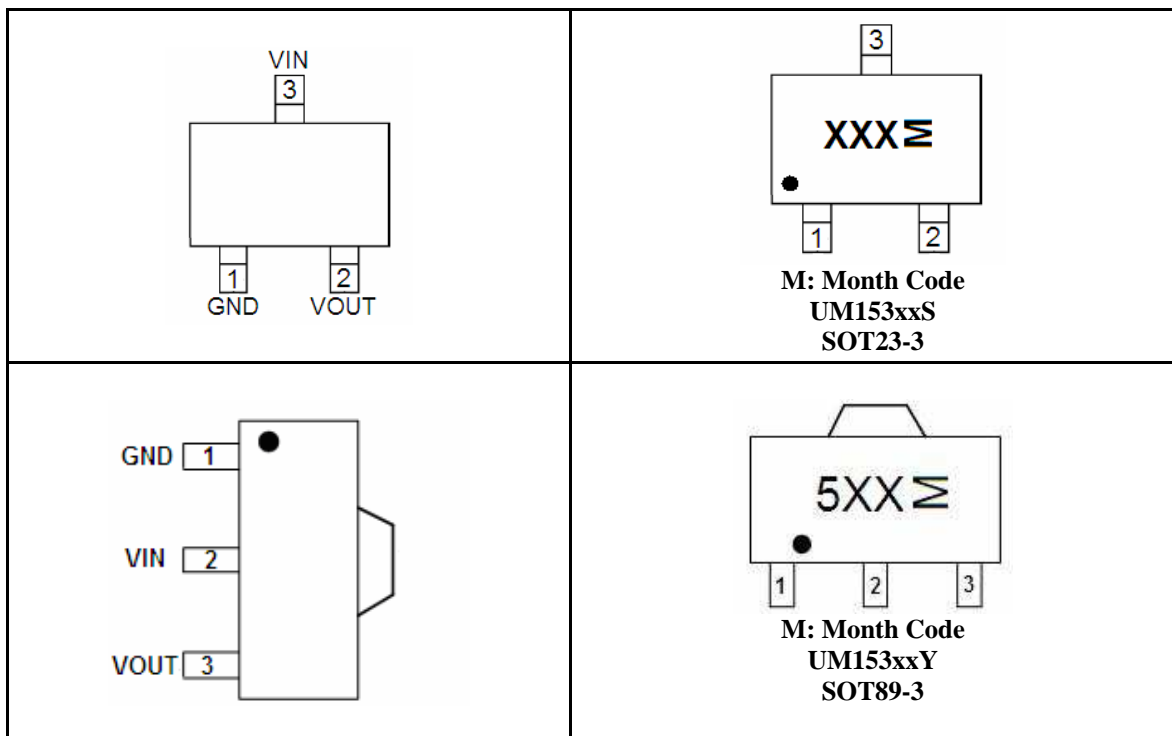

**Available Voltage Version**

Part Number	Output Voltage	Marking Code	Package
UM15313S	1.3V	UC3	SOT23-3
UM15315S	1.5V	UC5	SOT23-3
UM15318S	1.8V	UC8	SOT23-3
UM15325S	2.5V	UD5	SOT23-3
UM15327S	2.7V	UD7	SOT23-3
UM15328S	2.8V	UD8	SOT23-3
UM15330S	3.0V	UDA	SOT23-3
UM15333S	3.3V	UG3	SOT23-3
UM15335S	3.5V	UG5	SOT23-3
UM15336S	3.6V	UG6	SOT23-3
UM15338S	3.8V	UG8	SOT23-3
UM15340S	4.0V	UGA	SOT23-3
UM15342S	4.2V	UI2	SOT23-3
UM15343S	4.3V	UI3	SOT23-3
UM15345S	4.5V	UI5	SOT23-3
UM15347S	4.7V	UI7	SOT23-3
UM15348S	4.8V	UI8	SOT23-3
UM15350S	5.0V	UIA	SOT23-3
UM15313Y	1.3V	5A3	SOT89-3
UM15315Y	1.5V	5C5	SOT89-3
UM15318Y	1.8V	5C8	SOT89-3
UM15325Y	2.5V	5D5	SOT89-3
UM15327Y	2.7V	5D7	SOT89-3
UM15328Y	2.8V	5D8	SOT89-3
UM15330Y	3.0V	5AA	SOT89-3
UM15333Y	3.3V	5G3	SOT89-3
UM15335Y	3.5V	5G5	SOT89-3
UM15336Y	3.6V	5G6	SOT89-3
UM15338Y	3.8V	5G8	SOT89-3
UM15340Y	4.0V	5GA	SOT89-3
UM15342Y	4.2V	5GC	SOT89-3
UM15343Y	4.3V	5GD	SOT89-3
UM15345Y	4.5V	5GH	SOT89-3
UM15347Y	4.7V	5GM	SOT89-3
UM15348Y	4.8V	5GJ	SOT89-3
UM15350Y	5.0V	5GN	SOT89-3

## Absolute Maximum Ratings (Note 1)

Symbol	Parameter	Value	Unit
$V_{IN}$	Supply Voltage on IN Pin	-0.3 to +6.5	V
$V_{OUT}$	Voltage on OUT Pin	-0.3 to +7.5	V
$T_J$	Operating Junction Temperature (Notes 2, 3)	-40 to +125	°C
$T_{STG}$	Storage Temperature Range	-65 to +150	°C
$T_L$	Lead Temperature for Soldering 10 seconds	+300	°C

## Recommended Operating Conditions (Note 4)

Supply Input Voltage	2.2 V to 5.5V
Junction Temperature Range	-40°C to 125°C
Ambient Temperature Range	-40°C to 85°C

Note 1: Absolute Maximum Ratings are those values beyond which the life of a device may be impaired.

Note 2: The device is guaranteed to meet performance specifications from 0°C to 70°C. Specifications over the -40°C to 125°C operating junction temperature range are guaranteed by design, characterization and correlation with statistical process controls.

Note 3: This IC includes over temperature protection circuit inside that is intended to protect the device during momentary overload conditions. Over temperature protection trip point is around 160°C. Continuous operation above the specified maximum operating junction temperature may impair device reliability.

Note 4: The device is not guaranteed to function outside its operating conditions.

## Internal Block Diagram

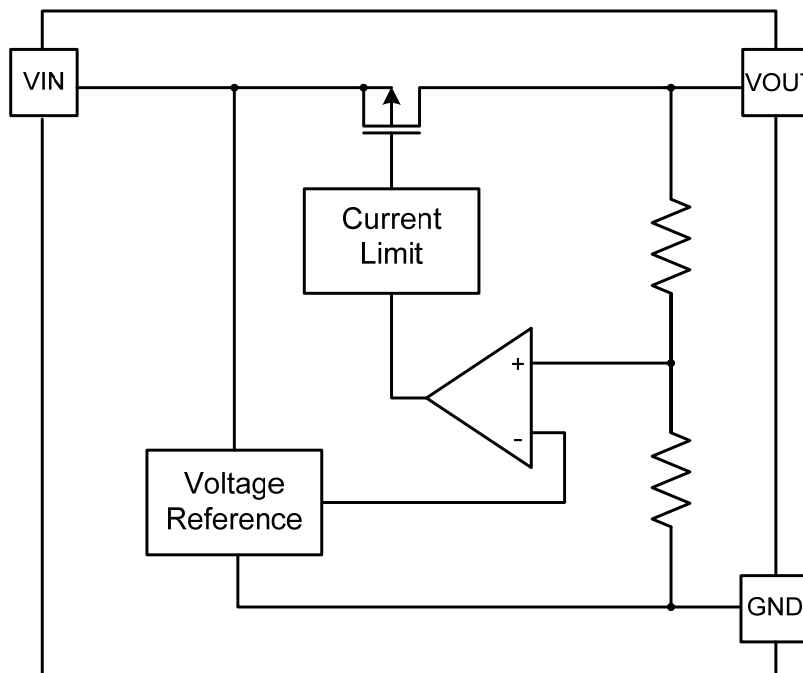

**Electrical Characteristics**

$V_{IN}=+5V\pm 10\%$ ,  $C_{IN}=1\mu F$ ,  $C_{OUT}=1\mu F$ ,  $T_A=-40^\circ C$  to  $+85^\circ C$ . Typical conditions are at  $V_{IN}=5V$ ,  $T_A=25^\circ C$ .

Symbol	Parameter	Test Conditions	Min	Typ	Max	Unit
$V_{IN}$	Input Voltage Range		2.2		5.5	V
$V_{OUT}$	Output Voltage Range		1.3		5.0	V
$I_Q$	Quiescent Current	$I_{OUT}=0mA, V_{IN}=5.0V$		1.2	3	$\mu A$
$I_{OUT}$	Output Current	$V_{IN}\geq 3V$	100			mA
		$V_{IN}\geq 3.5V$	200			mA
	Output Voltage Accuracy	$V_{IN}=V_{OUT}+1V(V_{IN}\geq 3V)$ , $1mA\leq I_{OUT}\leq 30mA$	-2.0		+2.0	%
$\Delta V_{DO}$	Dropout Voltage	$V_{out}\leq 1.8V, I_{OUT}=100mA$			2.6-Vout	V
		$V_{out}\geq 2.5V, I_{OUT}=100mA$			0.7	
$I_{LIMIT}$	Current Limit			300		mA
	Output Voltage TC			150		ppm/ $^\circ C$
$T_{SHDN}$	Thermal-Shutdown Temperature			160		$^\circ C$
$\Delta T_{SHDN}$	Thermal-Shutdown Hysteresis			20		$^\circ C$
	Line Regulation	$V_{OUT}+1V\leq V_{IN}\leq 5.5V$ ( $V_{IN}\geq 3V$ ), $I_{OUT}=30mA$		$\pm 0.3$	$\pm 0.5$	%
	Load Regulation	$V_{IN}=V_{OUT}+1V(V_{IN}\geq 3V)$ , $1mA\leq I_{OUT}\leq 100mA$		10		mV
	Output Voltage Noise	10-100kHz, $C_{IN}=1\mu F$ , $I_{OUT}=1mA$ , UM15318S		170		$\mu V_{rms}$
PSRR	Power Supply Ripple Rejection	$V_{IN}=V_{OUT}+1V$ $I_{OUT}=10mA$	F=10Hz		55	dB
			F=100Hz		45	
			F=1KHz		45	

## Typical Performance Characteristics

Quiescent Current vs Input Voltage

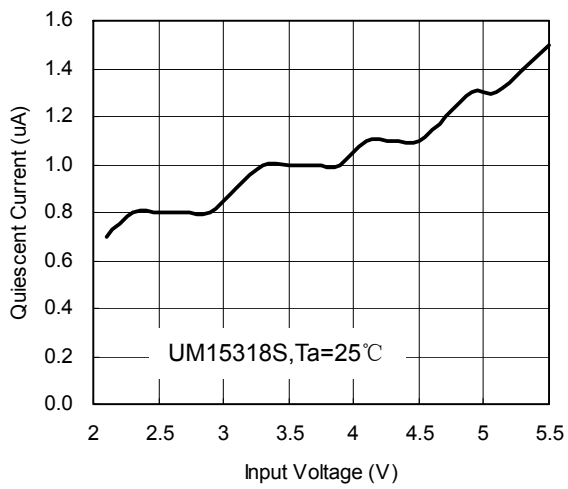

Quiescent Current vs Ambient Temperature

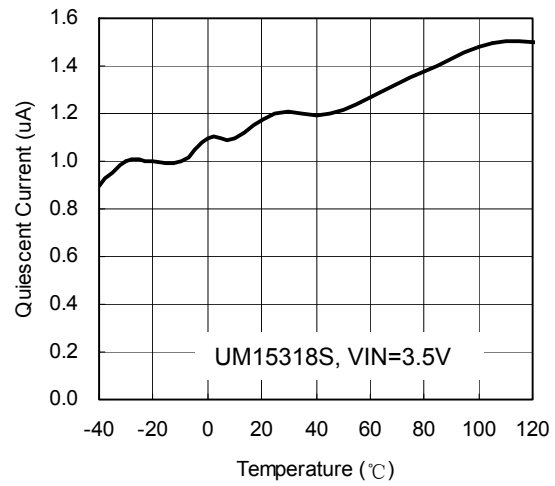

Output Voltage vs Input Voltage

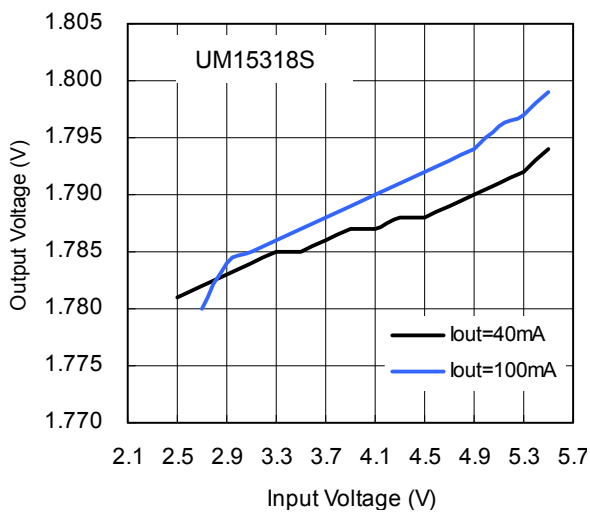

Output Voltage vs Output Current

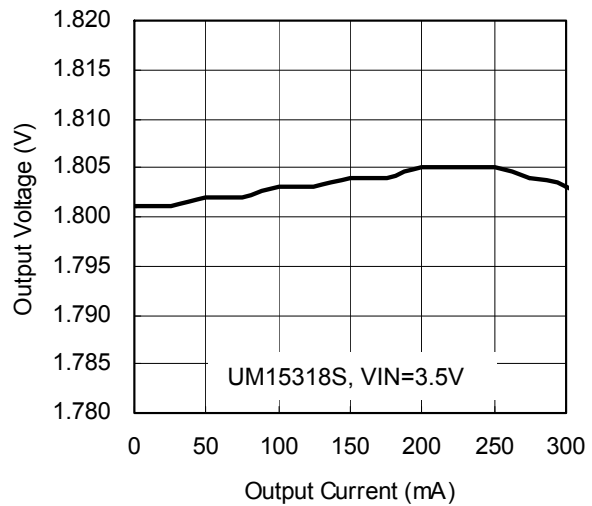

Output Voltage vs Ambient Temperature

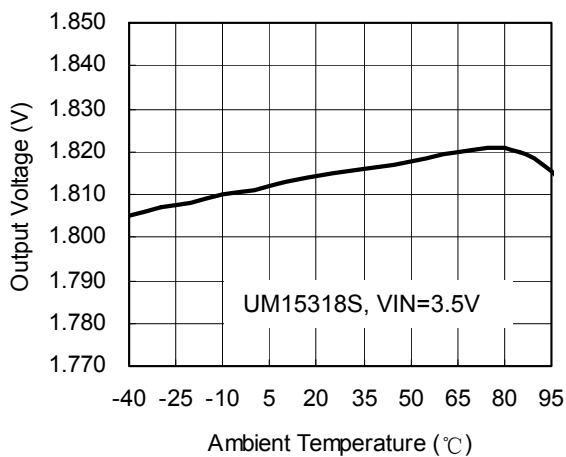

## Typical Performance Characteristics (Continued)

### Line Transient Response

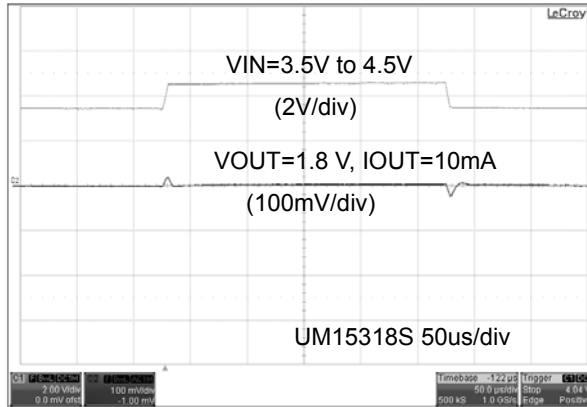

### Load Transient Response

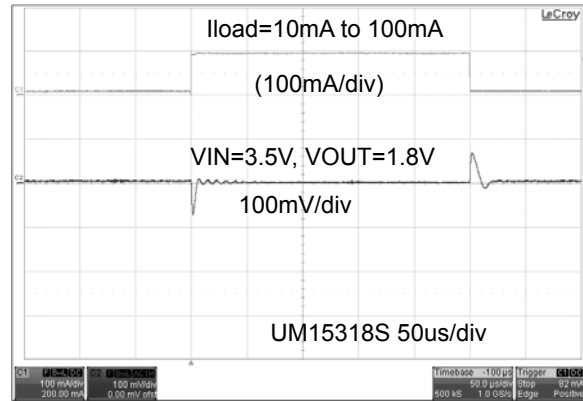

## Typical Application Circuit

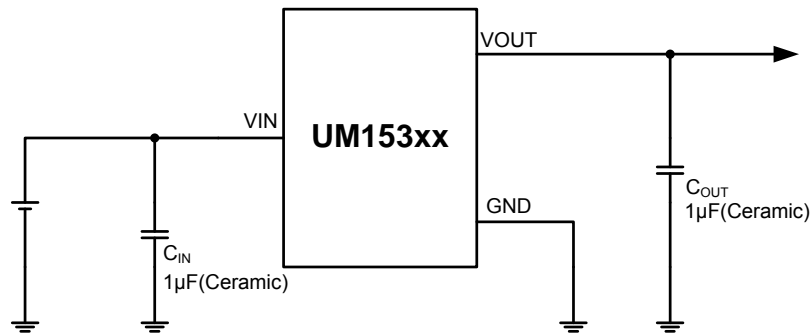

## Applications Information

### Output Capacitance and Transient Response

The UM153xx series regulators are designed to be stable with a wide range of output capacitors. The ESR of the output capacitor affects stability, most notably with small capacitors. A minimum output capacitor of 1µF with an ESR of 0.3Ω or less is recommended to ensure stability. The device's output transient response will be a function of output capacitance. Larger values of output capacitance decrease the peak deviations and provide improved transient response for larger load current changes. Extra consideration must be given to the use of ceramic capacitors. The X5R and X7R dielectrics result in more stable characteristics and are more suitable for use as the output capacitor. The X7R type has better stability across temperature, while the X5R is less expensive and is available in higher values.

### Thermal Protection

Thermal protection disables the output when the junction temperature rises to approximately +160°C allowing the device to cool. When the junction temperature cools to approximately +140°C the output circuit is again enabled.

## Package Information

### UM153xxS SOT23-3

#### Outline Drawing

DIMENSIONS				
Symbol	MILLIMETERS		INCHES	
	Min	Max	Min	Max
A	1.050	1.250	0.041	0.049
A1	0.000	0.100	0.000	0.004
A2	1.050	1.150	0.041	0.045
b	0.300	0.500	0.012	0.020
c	0.100	0.200	0.004	0.008
D	2.820	3.020	0.111	0.119
E	1.500	1.700	0.059	0.067
E1	2.650	2.950	0.104	0.116
e	0.950REF		0.037REF	
e1	1.800	2.000	0.071	0.079
L	0.550REF		0.022REF	
L1	0.300	0.600	0.012	0.024
$\theta$	0°	8°	0°	8°

#### Land Pattern

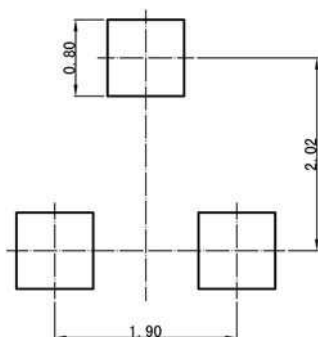
	<p>NOTES:</p> <ol style="list-style-type: none"> <li>Compound dimension: 2.92×1.60;</li> <li>Unit: mm;</li> <li>General tolerance ±0.05mm unless otherwise specified;</li> <li>The layout is just for reference.</li> </ol>
---	---

#### Tape and Reel Orientation



## UM153xxY SOT89-3

### Outline Drawing

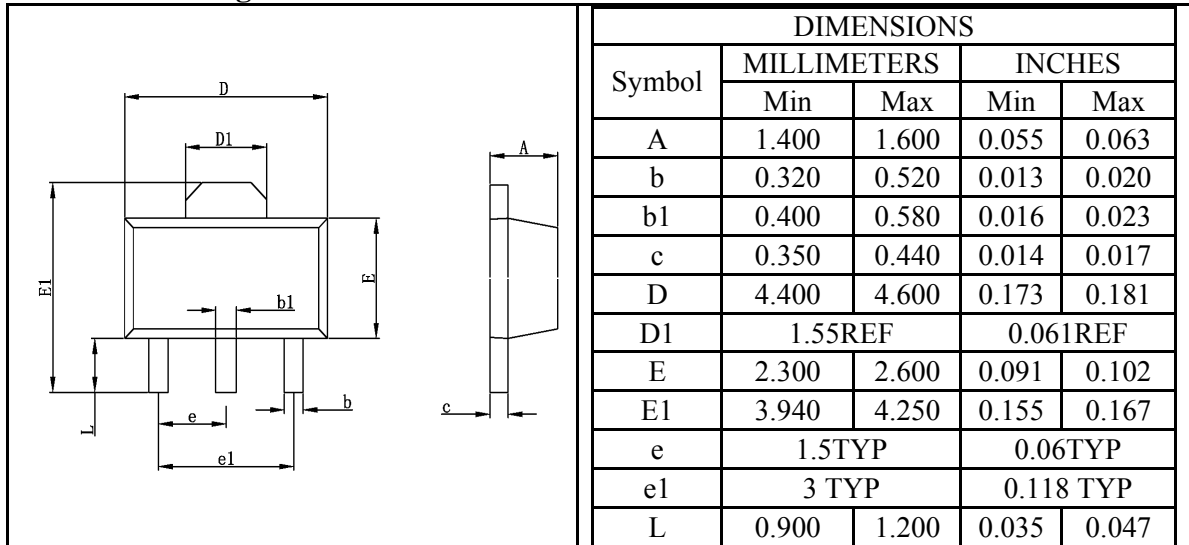

### Land Pattern

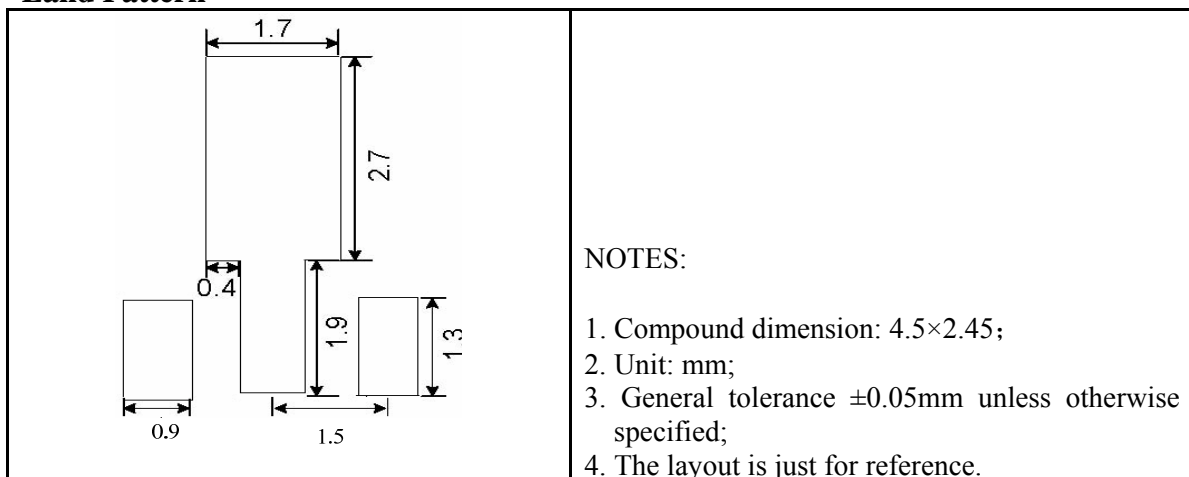

### Tape and Reel Orientation

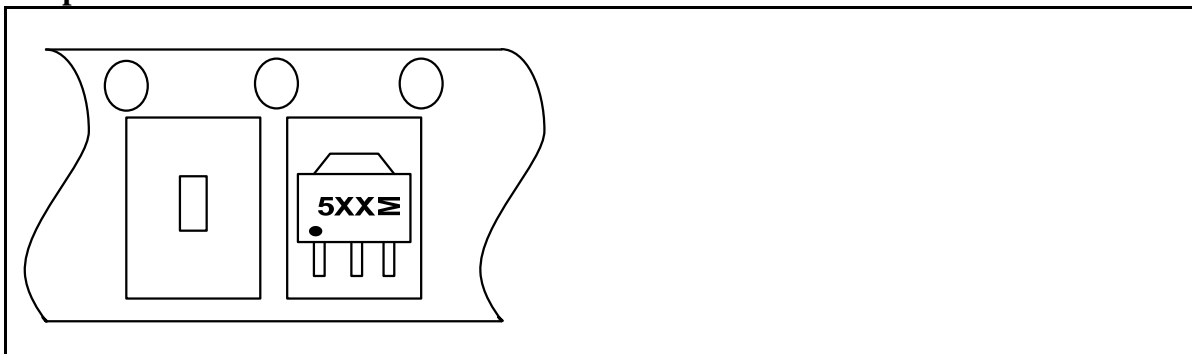

---

**IMPORTANT NOTICE**

The information in this document has been carefully reviewed and is believed to be accurate. Nonetheless, this document is subject to change without notice. Union assumes no responsibility for any inaccuracies that may be contained in this document, and makes no commitment to update or to keep current the contained information, or to notify a person or organization of any update. Union reserves the right to make changes, at any time, in order to improve reliability, function or design and to attempt to supply the best product possible.



Union Semiconductor, Inc

Add: 2F, No. 3, Lane647 Songtao Road, Shanghai 201203

Tel: 021-51093966

Fax: 021-51026018

Website: [www.union-ic.com](http://www.union-ic.com)