

Low Power DC/DC Boost Converter

UM1660S SOT23-5

General Description

The UM1660S is a PFM controlled step-up DC-DC converter with a switching frequency up to 1MHz. The device is ideal to generate output voltage for small to medium LCD bias supplies and white LED backlight supplies from a single cell Li-Ion battery. The part can also be used to generate standard 3.3V/5V to 12V power conversions.

With a high switching frequency of 1MHz, a low profile and small board area solution can be achieved using a chip coil and an ultra small ceramic output capacitor. The UM1660S has an internal 400mA switch current limit, offering lower output voltage ripple. The low quiescent current (typically 36 μ A) together with an optimized control scheme, allows device operation at very high efficiencies over the entire load current range.

Applications

- LCD Bias Supply
- White LED Supply for LCD Backlights
- Digital Still Camera
- PDAs, Organizers and Handheld PCs
- Cellular Phones
- Standard 3.3V/5V to 12V Conversion

Features

- 2.0V to 6.0V Input Voltage Range
- Adjustable Output Voltage up to 28V
- 400mA Internal Switch Current
- Up to 1MHz Switching Frequency
- 36 μ A Typical No Load Quiescent Current
- 1 μ A Maximum Shutdown Current
- Internal Soft-Start
- Available in Tiny SOT23-5 Package

Pin Configurations

Top View

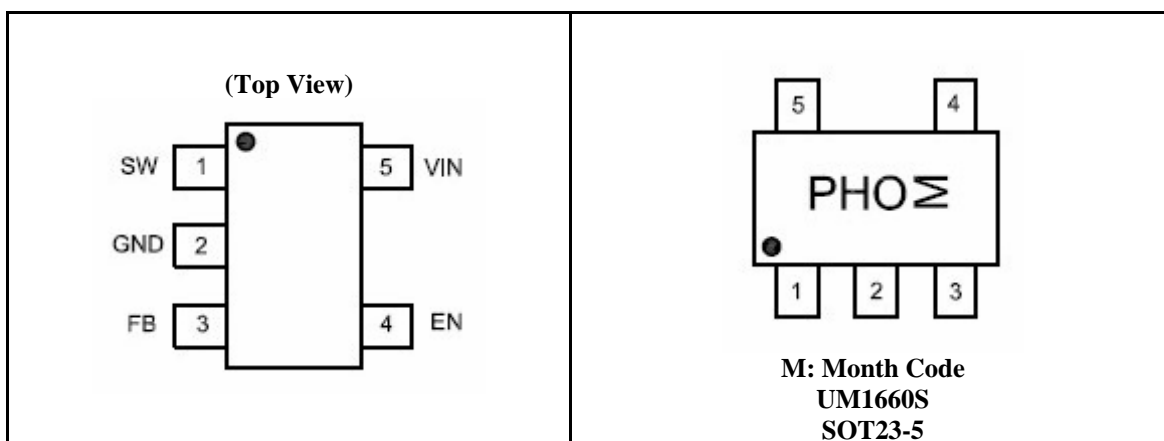

Ordering Information

Part Number	Packaging Type	Marking Code	Shipping Qty
UM1660S	SOT23-5	PHO	3000pcs/7Inch Tape & Reel

Pin Description

Pin Number	Symbol	Function
1	SW	Connect the inductor and the Schottky diode to this pin. This is the switch pin and is connected to the drain of the internal power MOSFET.
2	GND	Ground
3	FB	This is the feedback pin of the device. Connect this pin to the external voltage divider to program the desired output voltage.
4	EN	This is the enable pin of the device. Pulling this pin to ground forces the device into shutdown mode reducing the supply current to less than 1μA. This pin should not be left floating and needs to be terminated.
5	VIN	Supply voltage pin

Absolute Maximum Ratings

Over operating free-air temperature (unless otherwise noted) (Note 1)

Symbol	Parameter	Value	Unit
V_{IN}	Supply Voltage on VIN (Note 2)	-0.3 to +7.0	V
V_{FB}, V_{EN}	Voltages on FB, EN (Note 2)	-0.3 to $V_{IN} + 0.3$	V
V_{SW}	Switch Voltage on SW (Note 2)	30	V
P_D	Continuous Power Dissipation at $T_A = 25^\circ\text{C}$	350	mW
T_J	Operating Junction Temperature	-40 to +150	$^\circ\text{C}$
T_{STG}	Storage Temperature Range	-65 to +150	$^\circ\text{C}$
T_L	Maximum Lead Temperature for Soldering 10 seconds	+260	$^\circ\text{C}$

Note 1: Stresses beyond those listed under absolute maximum ratings may cause permanent damage to the device. These are stress ratings only, and functional operation of the device at these or any other conditions beyond those indicated under recommended operating conditions is not implied. Exposure to absolute-maximum-rated conditions for extended periods may affect device reliability.

Note 2: All voltage values are with respect to network ground terminal.

Recommended Operating Conditions

Symbol	Parameter	Min	Typ	Max	Unit
V_{IN}	Input Voltage Range	2.0		6.0	V
V_{OUT}	Output Voltage Range			28	V
L	Inductor (Note 3)	2.2	10		μH
f	Switching Frequency (Note 3)			1	MHz
C_{IN}	Input Capacitor (Note 3)		4.7		μF
C_{OUT}	Output Capacitor (Note 3)	1			μF
T_A	Operating Ambient Temperature	-40		85	$^\circ\text{C}$
T_J	Operating Junction Temperature	-40		125	$^\circ\text{C}$

Note 3: Refer to application section for further information.

Electrical Characteristics

($V_{IN}=2.4\text{ V}$, $EN = V_{IN}$, $C_{IN}=4.7\mu\text{F}$, $C_{OUT}=1\mu\text{F}$, $L=10\mu\text{H}$, $T_A = -40^\circ\text{C}$ to 85°C , typical values are at $T_A = 25^\circ\text{C}$, unless otherwise noted)

Symbol	Parameter	Test Conditions	Min	Typ	Max	Unit
SUPPLY CURRENT						
V_{IN}	Input Voltage Range		2.0		6.0	V
I_Q	Operating Quiescent Current	$I_{OUT}=0\text{mA}$, not switching $V_{FB} = 1.3\text{V}$		36	70	μA
I_{SD}	Shutdown Current	$EN=GND$		0.1	1	μA
V_{UVLO}	Under-voltage Lockout Threshold			1.5	1.8	V
ENABLE						
V_{IH}	EN High Level Input Voltage		1.3			V
V_{IL}	EN Low Level Input Voltage				0.4	V
I_L	EN Input Leakage Current	$EN=GND$ or V_{IN}		0.1	1	μA
POWER SWITCH AND CURRENT LIMIT						
V_{SW}	Maximum Switch Voltage				28	V
t_{ON}	Maximum On Time		4	6	7.5	μs
t_{OFF}	Minimum Off Time		250	400	550	ns
$R_{DS(ON)}$	MOSFET On Resistance	$V_{IN} = 2.4\text{V}$, $I_{SW}=50\text{mA}$		750	1200	$\text{m}\Omega$
	MOSFET Leakage Current	$V_{SW}=28\text{V}$		1	10	μA
I_{LIM}	MOSFET Current Limit		350	400	450	mA
OUTPUT						
V_{OUT}	Adjustable Output Voltage Range		V_{IN}		28	V
V_{REF}	Internal Voltage Reference			1.233		V
I_{FB}	Feedback Input Bias Current	$V_{FB} = 1.3\text{V}$			1	μA
V_{FB}	Feedback Trip Point Voltage	$2.0\text{V} \leq V_{IN} \leq 6.0\text{V}$	1.196	1.233	1.270	V
	Line Regulation (Note 4)	$2.0\text{V} \leq V_{IN} \leq 6.0\text{V}$; $V_{OUT}=18\text{V}$; $I_{LOAD}=10\text{mA}$		0.05		%/V
	Load Regulation (Note 4)	$V_{IN} = 2.4\text{V}$; $V_{OUT}=18\text{V}$; $0\text{mA} < I_{OUT} < 25\text{mA}$;		0.15		%/mA

Note 4: The line and load regulation depend on the external component selection.

Function Block Diagram

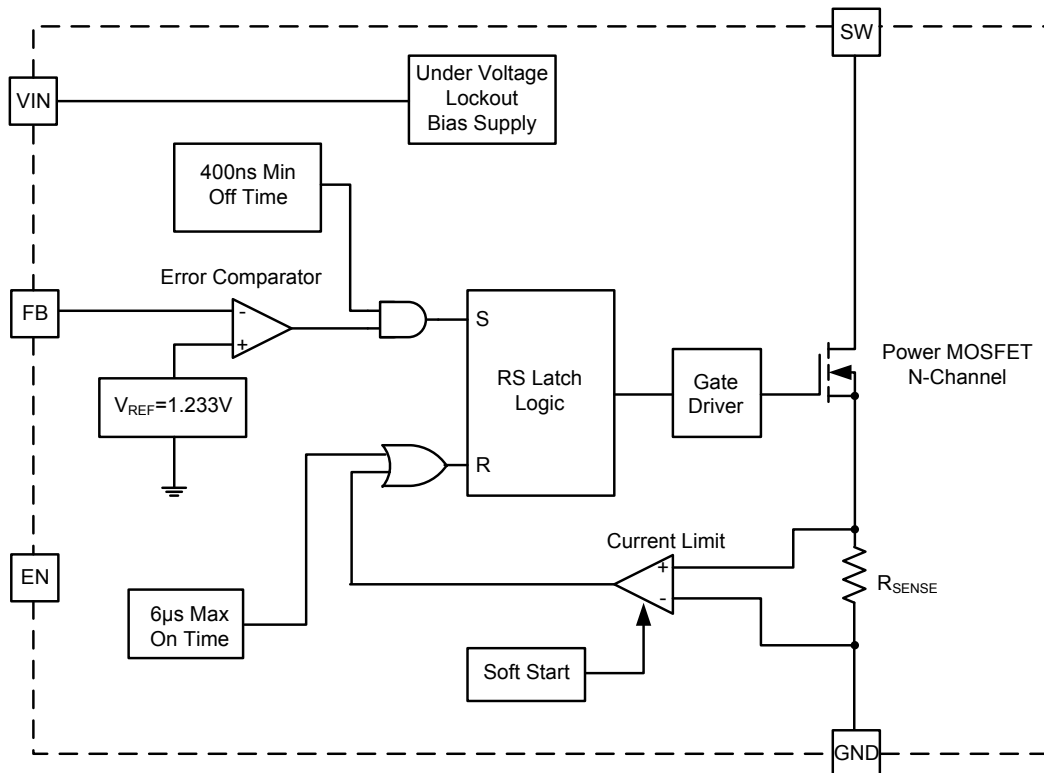

Figure 1. UM1660S function block diagram

Operation

The UM1660S features a constant off-time control scheme. Operation can be best understood by referring to the function block diagram. The converter monitors the output voltage, and as soon as the feedback voltage falls below the reference voltage of typically 1.233V, the internal switch turns on and the current ramps up. The switch turns off as soon as the inductor current reaches the internally set peak current of typically 400mA. The second criteria that turns off the switch is the maximum on-time of 6µs (typical). This is just to limit the maximum on-time of the converter to cover for extreme conditions. As the switch is turned off the external Schottky diode is forward biased delivering the current to the output. The switch remains off for a minimum of 400ns (typical), or until the feedback voltage drops below the reference voltage again. Using this PFM peak current control scheme the converter operates in discontinuous conduction mode (DCM) where the switching frequency depends on the output current, which results in very high efficiency over the entire load current range.

Peak Current Control

The internal switch turns on until the inductor current reaches the typical dc current limit (I_{LIM}) of 400mA. There is approximately a 100ns delay from the time the current limit is reached and when the internal logic actually turns off the switch. During this 100ns delay, the peak inductor current will increase. This increase demands a larger saturation current rating for the inductor. This saturation current can be approximated by the following equation:

$$I_{peak(typ)} = I_{LIM} + \frac{V_{in}}{L} \times 100ns$$

The higher the input voltage and the lower the inductor value, the greater the peak current.

Soft-Start

All inductive step-up converters exhibit high inrush current during start-up if no special precaution is made. This can cause voltage drops at the input rail during start up and may result in an unwanted or early system shut down. The UM1660S limits this inrush current by increasing the current limit in two steps from $I_{LIM}/4$ for 256 cycles to $I_{LIM}/2$ for the next 256 cycles, and then full current limit.

Enable

Pulling the enable pin (EN) to ground shuts down the device reducing the shutdown current to $1\mu A$ (typical). Since there is a conductive path from the input to the output through the inductor and Schottky diode, the output voltage is equal to the input voltage during shutdown. The enable pin needs to be terminated and should not be left floating. Using a small external transistor disconnects the input from the output during shutdown as shown in the figure below.

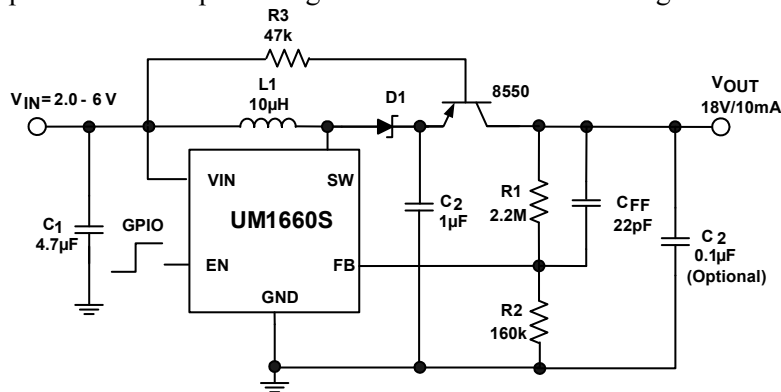

Figure 2. Disconnect the input from the output during shutdown using external transistor

Under-voltage Lockout

An under-voltage lockout prevents misoperation of the device at input voltages below typical 1.5 V. When the input voltage is below the under-voltage threshold the main switch is turned off.

Typical Application Circuit

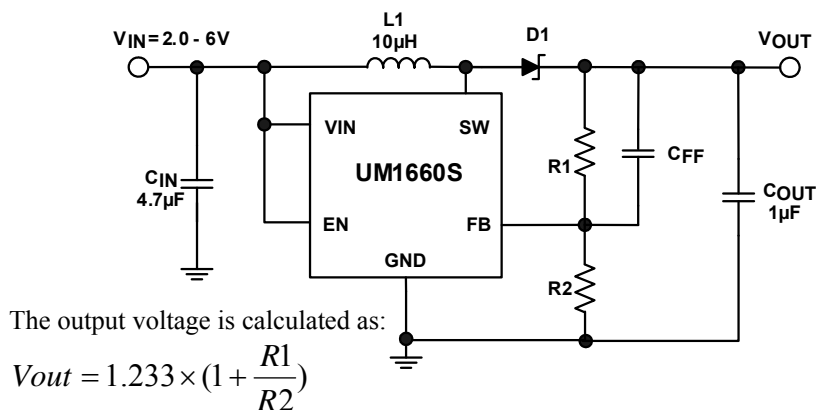

Figure 3. Standard DC/DC Boost Supply

We can use a PWM signal on the enable pin of UM1660S to adjust the white LED brightness (see figure 4 below). When adding the PWM signal to EN pin, the UM1660S is turned on or off by the PWM signal, so the LEDs operate at either zero or full current. The average LED current increases proportionally with the duty cycle of the PWM signal. The magnitude of the PWM signal should be higher than the minimum enable voltage of EN pin (1.3V) and lower than the V_{in} , in order to let the dimming control perform correctly. The frequency range of the PWM signal is from 50Hz to 10 kHz.

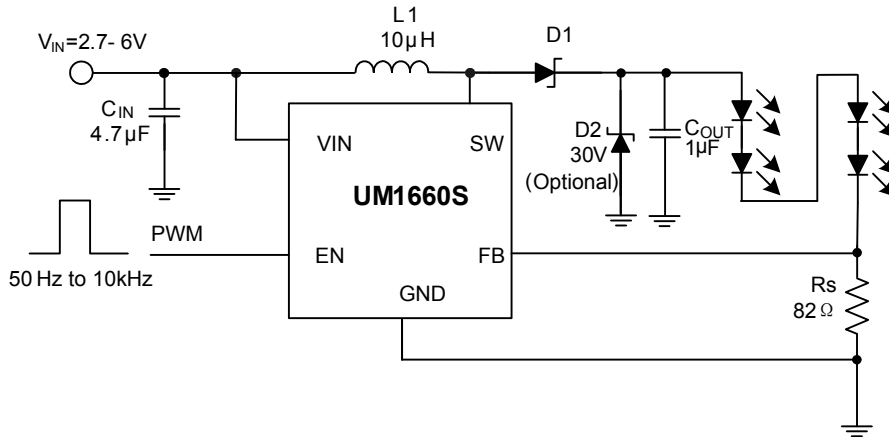
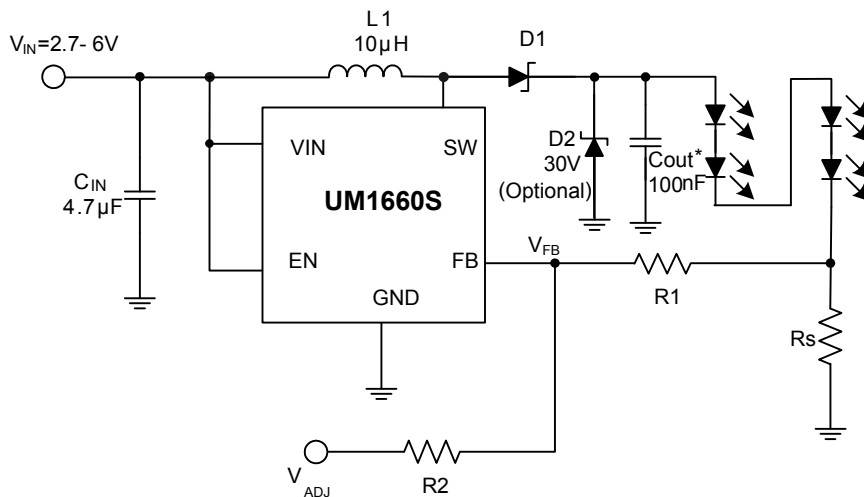

Figure 4.

White LED Supply with Adjustable Brightness Control Using a PWM Signal on the Enable Pin

We also can adjust the white LED brightness using an analog signal on the feedback pin (see figure 5 below). Add a DC voltage to the FB pin, and adjust the LED current by change the DC voltage, which control the brightness. The LED current is calculated as:

$$I_{RS} = \frac{V_{FB} \times (R_1 + R_2) - V_{ADJ} \times R_1}{R_S \times R_2}$$



*A smaller output capacitor value for C_{out} causes a larger LED ripple

Figure 5.

White LED Supply with Adjustable Brightness Control Using an Analog Signal on the Feedback Pin

Typical Operating Characteristics

($C_{IN}=4.7\mu F$, $C_{OUT}=1\mu F$, $L=10\mu H$, $T_A=25^\circ C$, unless otherwise noted)

Efficiency vs Output Current

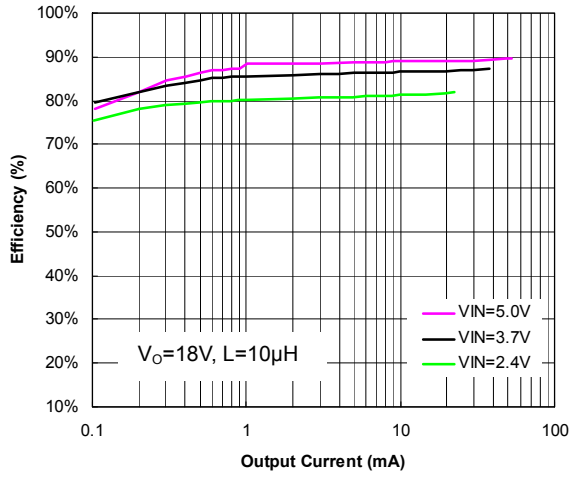

Efficiency vs Output Current

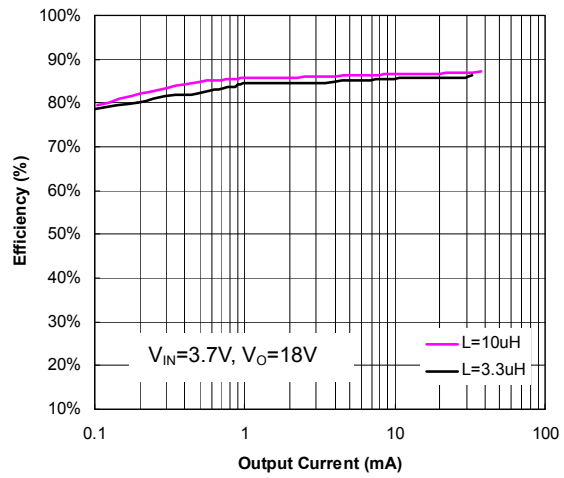

Efficiency vs Input Voltage

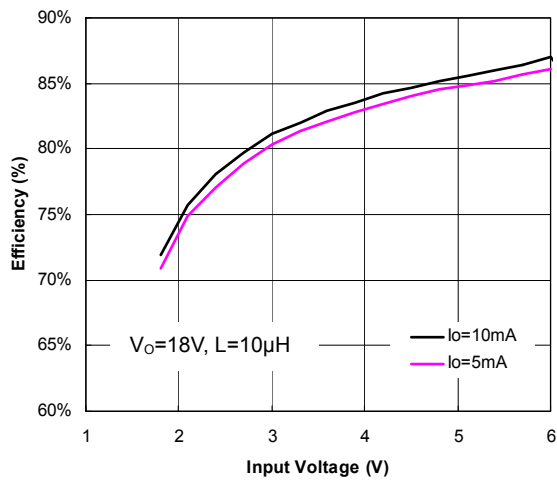

Quiescent Current vs Input Voltage

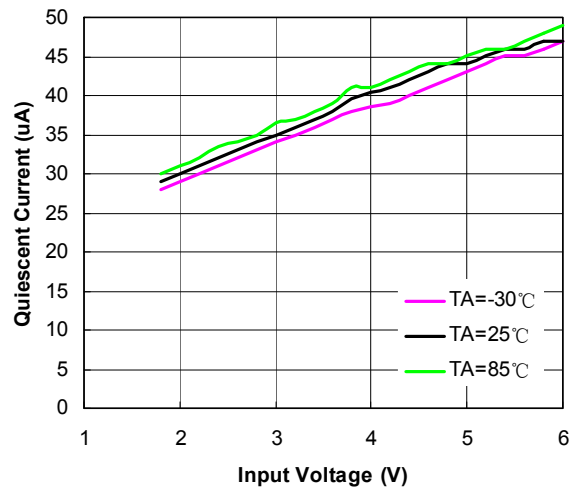

Feedback Voltage vs Temperature

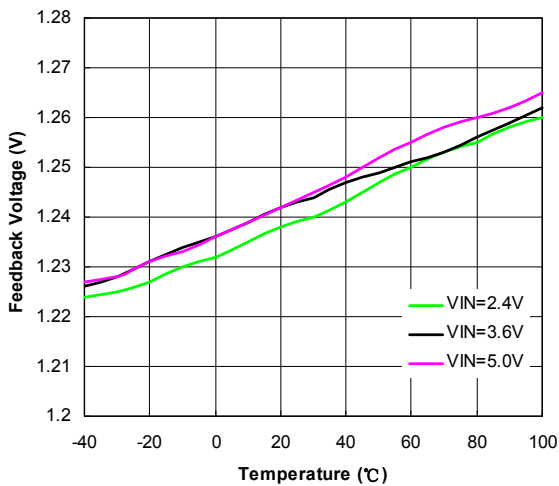

Switch Current Limit vs Temperature

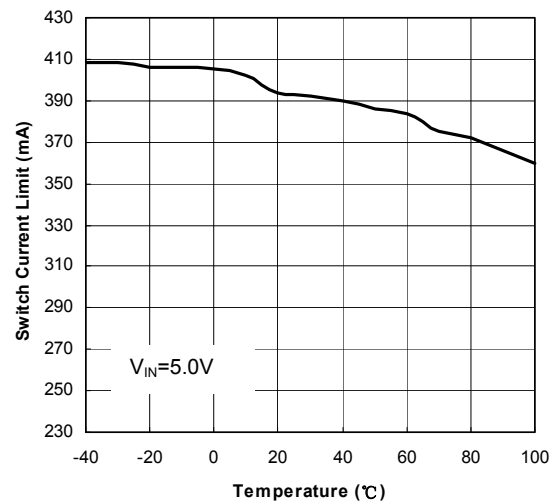

Typical Operating Characteristics (Continued)

($C_{IN}=4.7\mu F$, $C_{OUT}=1\mu F$, $L=10\mu H$, $T_A=25^\circ C$, unless otherwise noted)

Output Voltage vs Temperature

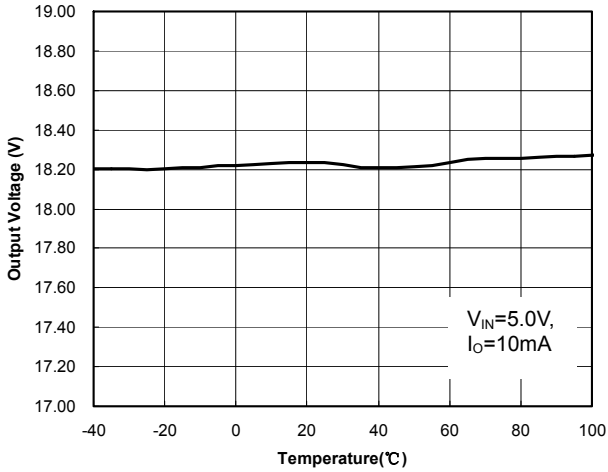

$R_{DS(ON)}$ vs Temperature

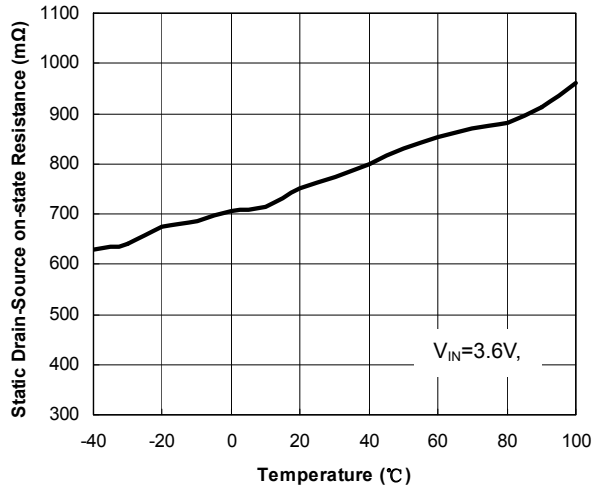

$R_{DS(ON)}$ vs Input Voltage

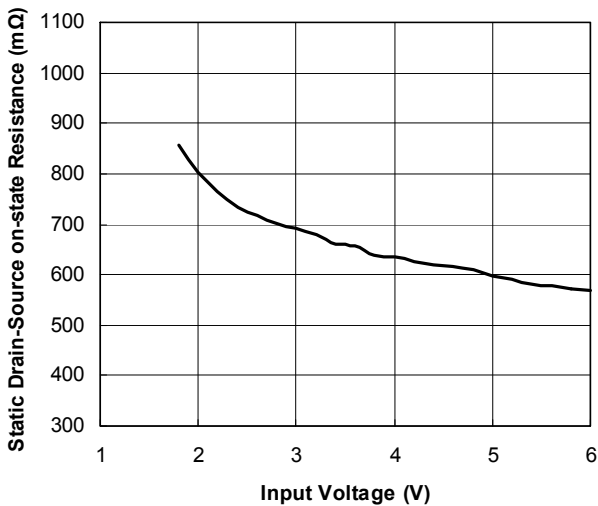

Line Transient Response

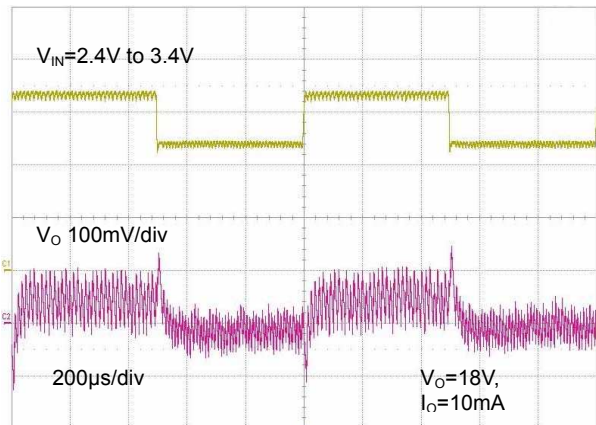

Load Transient Response

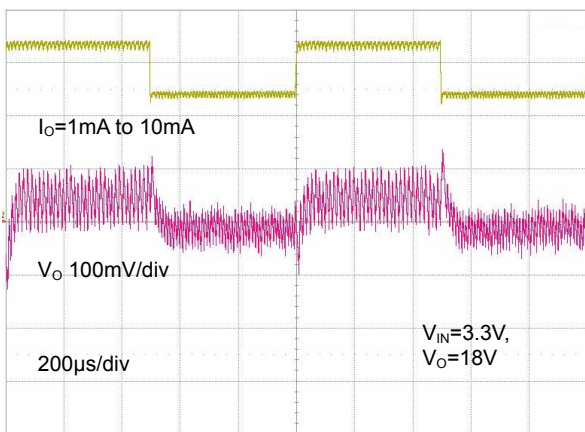

Start-up Behavior

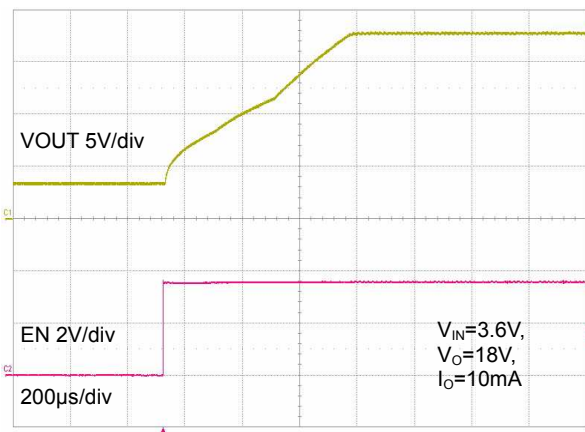

Applications Information

Inductor Selection, Maximum Load Current

Since the PFM peak current control scheme is inherently stable, the inductor value does not affect the stability of the regulator. The selection of the inductor together with the nominal load current, input and output voltage of the application determines the switching frequency of the converter. Depending on the application, inductor values between 2.2μH up to 33μH are recommended. The maximum inductor value is determined by the maximum on time of the switch, typically 6μs. The peak current limit of 400mA (typically) should be reached within this 6μs period for proper operation.

The inductor value determines the maximum switching frequency of the converter. Therefore, select the inductor value that ensures the maximum switching frequency at the converter maximum load current is not exceeded. The maximum switching frequency is calculated by the following formula:

$$f_{s_{\max}} = \frac{V_{in_{\min}} \times (V_{out} - V_{in})}{I_p \times L \times V_{out}}$$

Where:

I_p = Peak current as described in the previous peak current control section

L = Selected inductor value

$V_{in_{\min}}$ = The highest switching frequency occurs at the minimum input voltage

If the selected inductor value does not exceed the maximum switching frequency of the converter, the next step is to calculate the switching frequency at the nominal load current using the following formula:

$$f_s(I_{load}) = \frac{2 \times I_{load} \times (V_{out} - V_{in} + V_d)}{I_p^2 \times L}$$

Where:

I_p = Peak current as described in the previous peak current control section

L = Selected inductor value

I_{load} = Nominal load current

V_d = Rectifier diode forward voltage (typically 0.3V)

A smaller inductor value gives a higher converter switching frequency, but lowers the efficiency. The inductor value has less effect on the maximum available load current and is only of secondary order. The best way to calculate the maximum available load current under certain operating conditions is to estimate the expected converter efficiency at the maximum load current. This number can be taken out of the efficiency graphs shown in page 6. The maximum load current can then be estimated as follows:

$$I_{load_{\max}} = \eta \frac{I_p^2 \times L \times f_{s_{\max}}}{2 \times (V_{out} - V_{in})}$$

Where:

I_p = Peak current as described in the previous peak current control section

L = Selected inductor value

$f_{s_{\max}}$ = Maximum switching frequency as calculated previously

η = Expected converter efficiency. Typically 70% to 85%

The maximum load current of the converter is the current at the operation point where the converter starts to enter the continuous conduction mode. Usually the converter should always operate in discontinuous conduction mode.

Last, the selected inductor should have a saturation current that meets the maximum peak current of the converter (as calculated in the peak current control section). Use the maximum value for I_{LIM} for this calculation.

Another important inductor parameter is the dc resistance. The lower the dc resistance, the higher the efficiency of the converter.

Setting the Output Voltage

The output voltage is calculated as:

$$V_{out} = 1.233V \times \left(1 + \frac{R1}{R2}\right)$$

For battery powered applications a high impedance voltage divider should be used with a typical value for R2 of 200k Ω and a maximum value for R1 of 2.2M Ω . Smaller values might be used to reduce the noise sensitivity of the feedback pin.

A feedforward capacitor across the upper feedback resistor R1 is required to provide sufficient overdrive for the error comparator.

The lower the switching frequency of the converter, the larger the feedforward capacitor value required. A good starting point is to use a 10pF feedforward capacitor. As a first estimation, the required value for the feedforward capacitor at the operation point can also be calculated using the following formula:

$$C_{FF} = \frac{1}{2\pi \times \frac{f_s}{20} \times R1}$$

Where:

R1 = Upper resistor of voltage divider

f_s = Switching frequency of the converter at the nominal load current (See previous section for calculating the switching frequency)

C_{FF} = Choose a value that comes closest to the result of the calculation

The larger the feedforward capacitor the worse the line regulation of the device. Therefore, when concern for line regulation is paramount, the selected feedforward capacitor should be as small as possible.

Output Capacitor Selection

The output capacitor limits the output ripple and maintains the output voltage during large load transitions. Ceramic capacitors with X5R or X7R temperature characteristics are highly recommended due to their small size, low ESR, and small temperature coefficients. For most applications, a 1 μ F ceramic capacitor is sufficient. For some applications a reduction in output voltage ripple can be achieved by increasing the output capacitor.

Input Capacitor Selection

For good input voltage filtering, low ESR ceramic capacitors are recommended. A 4.7 μ F ceramic input capacitor is sufficient for most of the applications. For better input voltage filtering this value can be increased.

Diode Selection

Schottky diode is a good choice for UM1660S because of its low forward voltage drop and fast reverse recovery. Using Schottky diode can get better efficiency. The current rating of the diode should meet the peak current rating of the converter as it is calculated in the peak current control section. Use the maximum value for I_{LIM} for this calculation.

Lay out Considerations

High switching frequencies and relatively large peak currents make the PCB layout a very important part of design. Good design minimizes excessive EMI on the feedback paths and voltage gradients in the ground plane, resulting in a stable and well-regulated output. Good layout for the UM1660S can be implemented by following a few simple design rules.

1. The input capacitor should be placed as close as possible to the input pin for good input voltage filtering.
2. The inductor and diode should be placed as close as possible to the switch pin to minimize the noise coupling into other circuits.
3. The feedback network should be routed away from the inductor. The feedback pin and feedback network should be shielded with a ground plane or trace to minimize noise coupling into this circuit.
4. Wide traces should be used for connections in bold as shown in the Figure below. A star ground connection or ground plane minimizes ground shifts and noise.

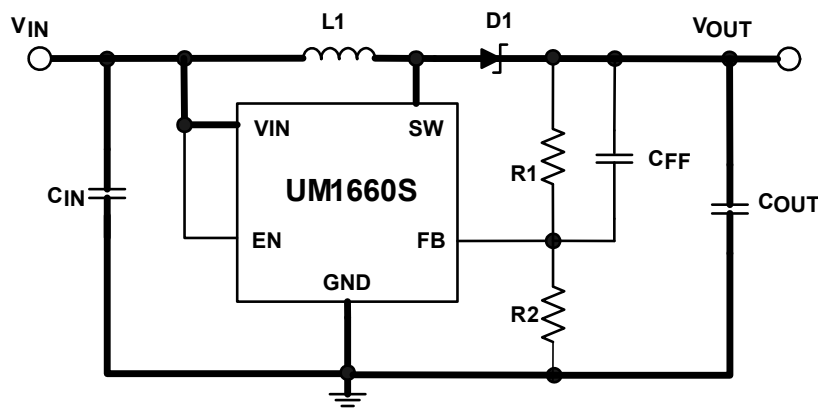

Package Information

UM1660S: SOT23-5

Outline Drawing

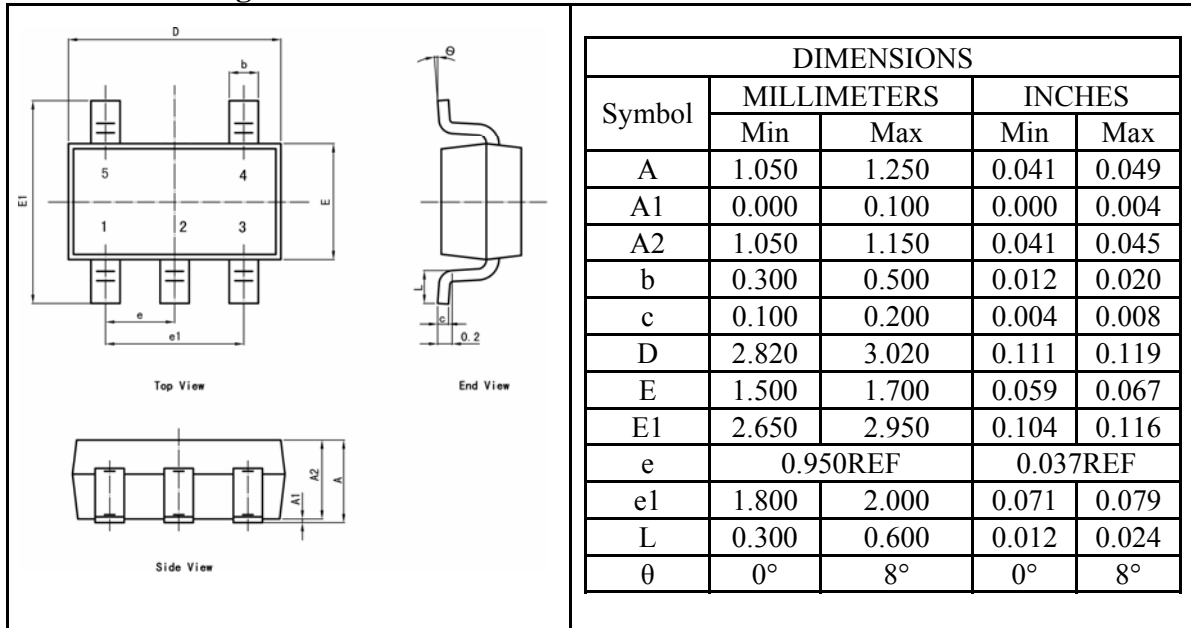

Land Pattern

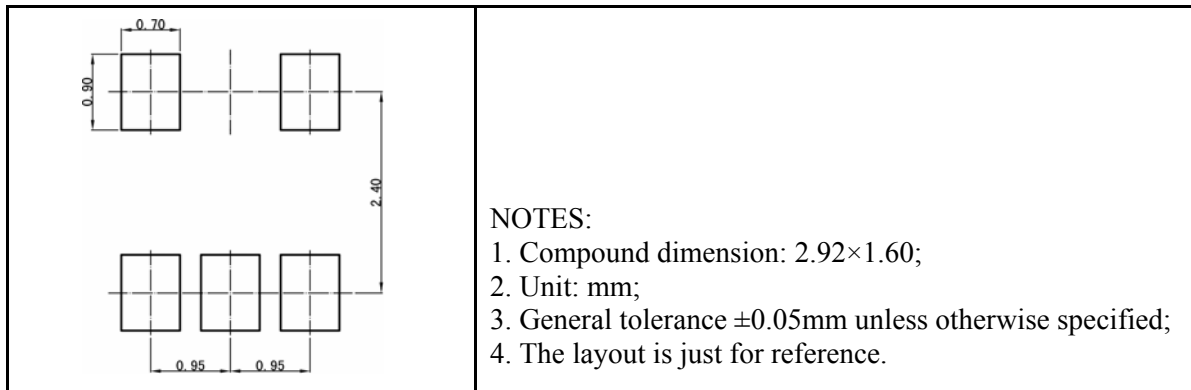

Tape and Reel Orientation



IMPORTANT NOTICE

The information in this document has been carefully reviewed and is believed to be accurate. Nonetheless, this document is subject to change without notice. Union assumes no responsibility for any inaccuracies that may be contained in this document, and makes no commitment to update or to keep current the contained information, or to notify a person or organization of any update. Union reserves the right to make changes, at any time, in order to improve reliability, function or design and to attempt to supply the best product possible.



Union Semiconductor, Inc

Add: 2F, No. 3, Lane 647 Songtao Road, Shanghai 201203

Tel: 021-51093966

Fax: 021-51026018

Website: www.union-ic.com

Union Semiconductor, Inc