

## 1.0A, 1.5MHz, Synchronous Step-Down DC-DC Converter UM3510 SOT23-5

### General Description

The UM3510 is a 1.5MHz constant frequency, slope compensated current mode PWM step-down converter. The device integrates a main switch and a synchronous rectifier for high efficiency without an external Schottky diode. It is ideal for powering portable equipment that runs from a single cell lithium-Ion (Li+) battery. The UM3510 can supply 1.0A of load current from a 2.5V to 5.5V input voltage. The output voltage can be regulated as low as 0.6V. The UM3510 can also run at 100% duty cycle for low dropout operation, extending battery life in portable system. Pulse Skipping Mode operation at light loads provides very low output ripple voltage for noise sensitive applications.

The UM3510 is available in a low profile SOT23-5 package.

### Applications

- Cellular and Smart Phones
- Microprocessors and DSP Core Supplies
- Wireless and DSL Modems
- PDAs, GPS
- MP3 Player
- Portable Instruments

### Features

- High Efficiency: Up to 96%
- 1.5MHz Constant Switching Frequency
- 1.0A Output Current
- Integrated Main switch and synchronous rectifier. No Schottky Diode Required
- 2.5V to 5.5V Input Voltage Range
- Output Voltage as Low as 0.6V
- 100% Duty Cycle in Dropout
- Low Quiescent Current: 200 $\mu$ A
- Slope Compensated Current Mode Control for Excellent Line and Load Transient Response
- Short Circuit Protection
- Thermal Fault Protection
- <1 $\mu$ A Shutdown Current
- Lead free SOT23-5 Package

### Pin Configurations

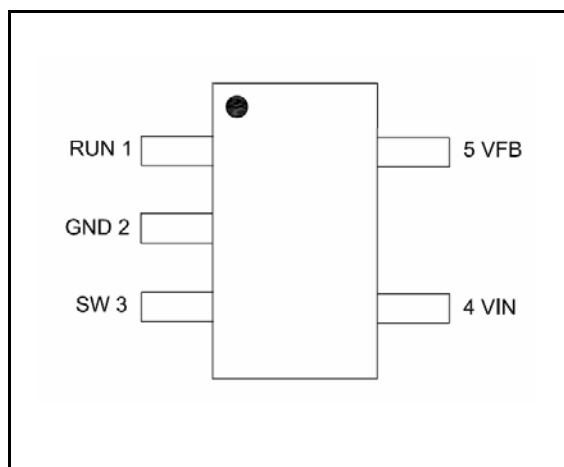

### Top View

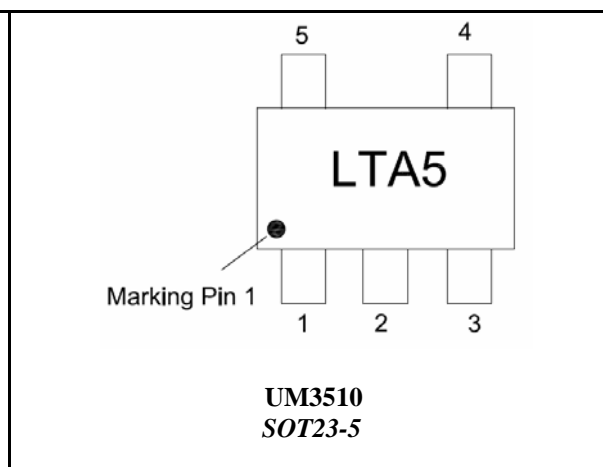

**Ordering Information**

Part Number	Packaging Type	Marking Code	Shipping Qty
UM3510	SOT23-5	LTA5	3000pcs/7Inch Tape & Reel

**Pin Description**

Pin Number	Symbol	Function
1	RUN	Regulator enable control input. Drive RUN above 1.0V to turn on the part. Drive RUN below 0.4V to turn it off. In shutdown, all functions are disabled drawing <math><1\mu\text{A}</math> supply current. Do not leave RUN floating.
2	GND	Ground.
3	SW	Power switch output. It is the switch node connection to Inductor. This pin connects to the drains of the internal P-CH and N-CH MOSFET switches.
4	VIN	Supply input pin. Must be closely decoupled to GND, Pin 2, with a 2.2 $\mu\text{F}$ or greater ceramic capacitor.
5	VFB	Feedback input pin. Connect FB to the center point of the external resistor divider.

**Absolute Maximum Ratings (Note 1)**

Symbol	Parameter	Value	Unit
$V_{IN}$	Input Voltage	-0.3 to +6.0	V
$V_{RUN}, V_{FB}$	RUN, VFB Voltages	-0.3 to $V_{IN}+0.3$	V
$V_{SW}$	SW Voltages	-0.3 to $V_{IN}+0.3$	V
$T_O$	Operating Temperature	-40 to +85	$^{\circ}\text{C}$
$T_{STG}$	Storage Temperature Range	-65 to +150	$^{\circ}\text{C}$

Note 1: Stresses greater than those listed under MAXIMUM RATINGS may cause permanent damage to the device. This is a stress rating only and functional operation of the device at these or any other conditions above those indicated in the operational sections of this specification is not implied. Exposure to absolute maximum rating conditions for extended periods may affect reliability.

**Electrical Characteristics (Note 2)**

 ( $V_{IN}=V_{RUN}=3.6V$ ,  $T_A=+25^{\circ}C$ , unless otherwise noted)

Symbol	Parameter	Test Conditions	Min	Typ	Max	Unit
$V_{IN}$	Input Voltage Range		2.5		5.5	V
$I_Q$ (Active)	Input DC Supply Current (Active Mode)	$V_{FB}=0.5V$ or $V_{OUT}=90\%$		200	300	$\mu A$
$I_Q$ (Shutdown)	Input DC Supply Current (Shutdown Mode)	$V_{FB}=0V$ , $V_{IN}=4.2V$		0.08	1.0	$\mu A$
$V_{FB}$	Regulated Feedback Voltage	$T_A = +25^{\circ}C$	0.5880	0.6000	0.6120	V
		$0^{\circ}C \leq T_A \leq 85^{\circ}C$	0.5865	0.6000	0.6135	
		$-40^{\circ}C \leq T_A \leq 85^{\circ}C$	0.5850	0.6000	0.6150	
$I_{FB}$	VFB Input Bias Current	$V_{FB}=0.65V$			$\pm 30$	nA
	Reference Voltage Line Regulation	$2.5V \leq V_{IN} \leq 5.5V$		0.11	0.40	%/V
	Output Voltage Line Regulation	$2.5V \leq V_{IN} \leq 5.5V$ , $I_{OUT}=10mA$		0.11	0.40	%/V
	Output Voltage Load Regulation	$100mA \leq I_{OUT} \leq 1.0A$		0.002		%/mA
$I_{O(Max)}$	Maximum Output Current	$V_{IN}=3.6V$ , $V_{OUT}=1.8V$	1.0			A
f	Oscillator Frequency	$V_{FB}=0.6V$ or $V_{OUT}=100\%$	1.2	1.5	1.8	MHz
$R_{DS(ON)}$	$R_{DS(ON)}$ of P-CH MOSFET	$V_{IN}=3.6V$ , $I_{SW}=100mA$		0.40	0.50	$\Omega$
	$R_{DS(ON)}$ of N-CH MOSFET	$V_{IN}=3.6$ , $I_{SW}=-100mA$		0.35	0.45	$\Omega$
$I_P$	Peak Inductor Current	$V_{IN}=3.0V$ , $V_{FB}=0.5V$ or $V_{OUT}=90\%$ , Duty Cycle < 35%		1.60		A
$I_{SWL}$	SW Leakage	$V_{RUN}=0V$ , $V_{SW}=0V$ or $5V$ $V_{IN}=5V$		$\pm 0.01$	$\pm 1$	$\mu A$
$V_H$	RUN High-Level Threshold	$-40^{\circ}C \leq T_A \leq 85^{\circ}C$	1.0			V
$V_L$	RUN Low-Level Threshold	$-40^{\circ}C \leq T_A \leq 85^{\circ}C$			0.4	V
$I_{RUNL}$	RUN Leakage Current			$\pm 0.1$	$\pm 1$	$\mu A$
$\eta_{(MAX)}$	Max. Efficiency	$V_{IN}=2.7V$ , $V_{OUT}=2.5V$	90			%
	Thermal Shutdown Temp			160		$^{\circ}C$

Note2: 100% production test at +25°C. Specifications over the temperature range are guaranteed by design and characterization.

**Block Diagram**

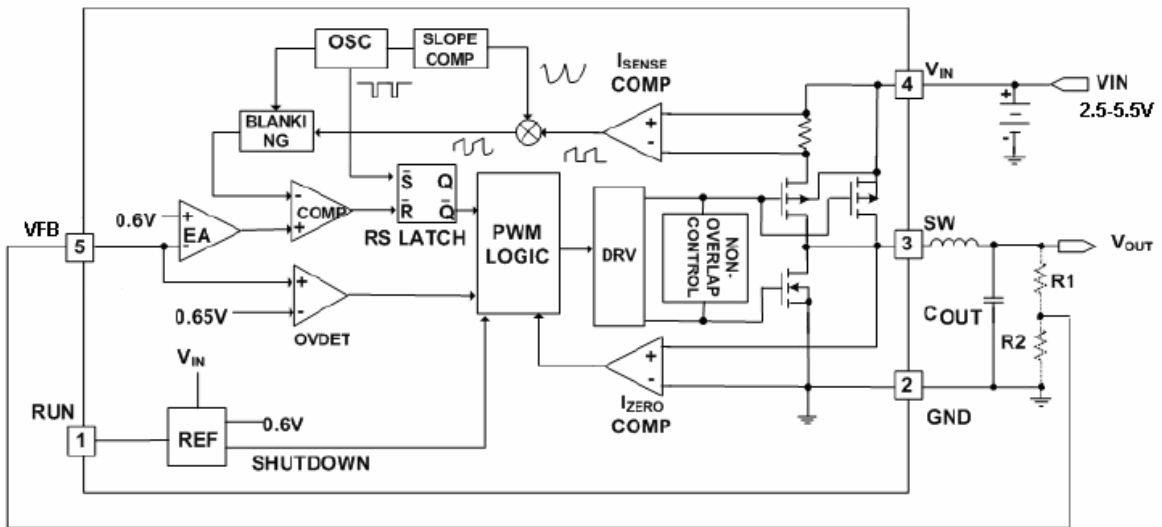

**Typical Application Circuit**

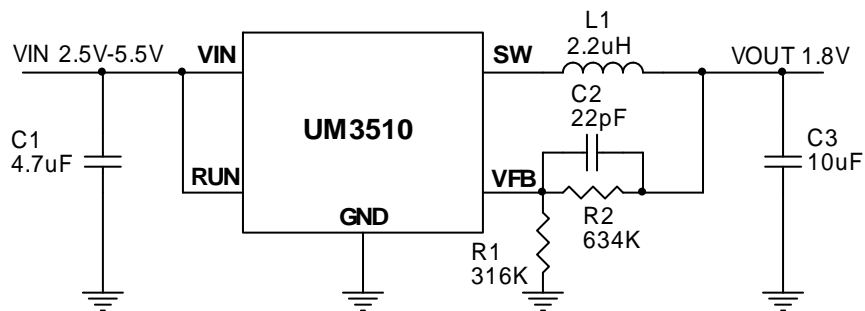

## Function description

UM3510 is a monolithic switching mode Step-Down DC-DC converter. It utilizes internal MOSFETs to achieve high efficiency and can generate very low output voltage by using internal reference at 0.6V. It operates at a fixed switching frequency, and uses the slope compensated current mode architecture. This Step-Down DC-DC Converter supplies 1.0A output current at  $V_{IN}=3.6V$  with input voltage range from 2.5V to 5.5V.

### Current Mode PWM Control

Slope compensated current mode PWM control provides stable switching and cycle-by-cycle current limit for excellent load and line responses and protection of the internal main switch (P-Ch MOSFET) and synchronous rectifier (N-CH MOSFET). During normal operation, the internal P-Ch MOSFET is turned on for a certain time to ramp the inductor current at each rising edge of the internal oscillator, and switched off when the peak inductor current is above the error voltage. The current comparator,  $I_{COMP}$ , limits the peak inductor current. When the main switch is off, the synchronous rectifier will be turned on immediately and stay on until either the inductor current starts to reverse, as indicated by the current reversal comparator,  $I_{ZERO}$ , or the beginning of the next clock cycle. The OVDET comparator controls output transient overshoots by turning the main switch off and keeping it off until the fault is no longer present.

### Pulse Skipping Mode Operation

At very light loads, the UM3510 automatically enters Pulse Skipping Mode. In the Pulse Skipping Mode, the inductor current may reach zero or reverse on each pulse. The PWM control loop will automatically skip pulses to maintain output regulation. The bottom MOSFET is turned off by the current reversal comparator,  $I_{ZERO}$ , and the switch voltage will ring. This is discontinuous mode operation, and is normal behavior for the switching regulator.

### Dropout Operation

When the input voltage decreases toward the value of the output voltage, the UM3510 allows the main switch to remain on for more than one switching cycle and increases the duty cycle (Note 1) until it reaches 100%. The output voltage then is the input voltage minus the voltage drop across the main switch and the inductor. At low input supply voltage, the  $R_{DS(ON)}$  of the P-Channel MOSFET increases, and the efficiency of the converter decreases. Caution must be exercised to ensure the heat dissipated not to exceed the maximum junction temperature of the IC.

Note 1: The duty cycle D of a step-down converter is defined as:

$$D = T_{ON} \times f_{OSC} \times 100\% \cong V_{OUT} / V_{IN} \times 100\%$$

Where  $T_{ON}$  is the main switch on time and  $f_{OSC}$  is the oscillator frequency (1.5Mhz).

### Maximum Load Current

The UM3510 will operate with input supply voltage as low as 2.5V, however, the maximum load current decreases at lower input due to large IR drop on the main switch and synchronous rectifier. The slope compensation signal reduces the peak inductor current as a function of the duty cycle to prevent sub-harmonic oscillations at duty cycles greater than 50%. Conversely the current limit increases as the duty cycle decreases.

## Typical Performance Characteristics

( $V_{IN} = 3.6V$ ,  $V_{OUT} = 1.8V$ ,  $T_A = +25^\circ C$ , unless otherwise noted.)

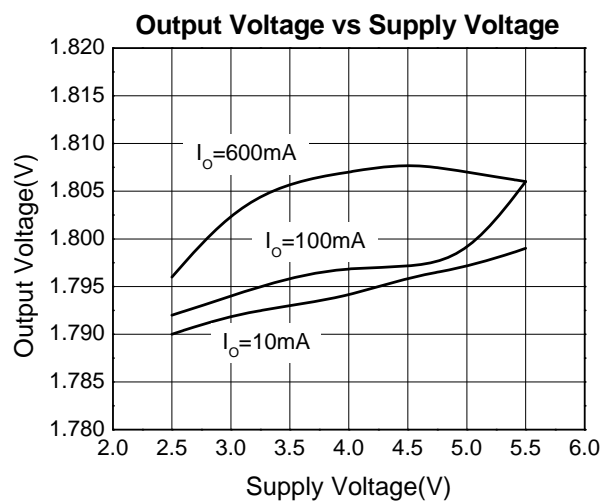
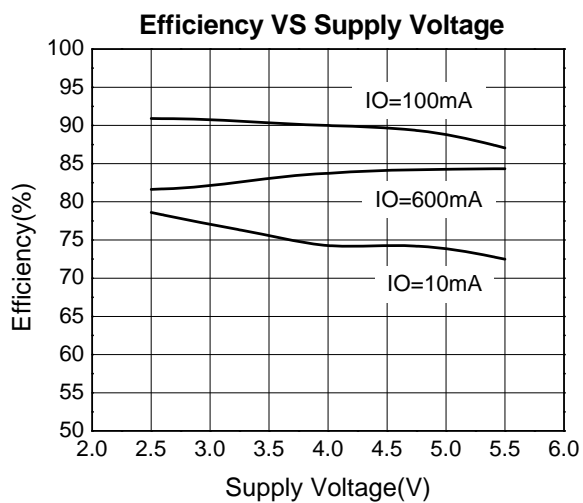
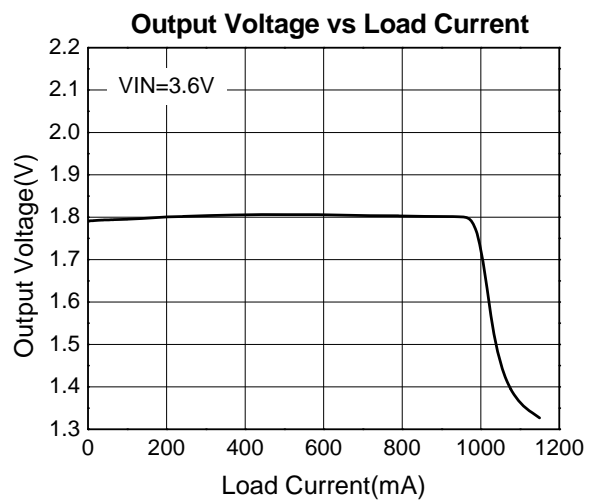
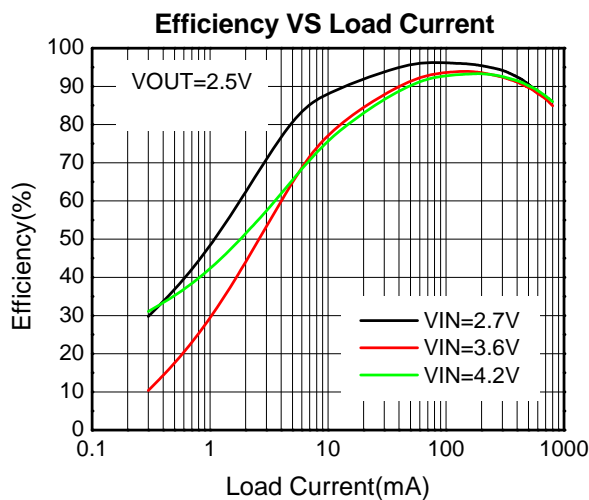
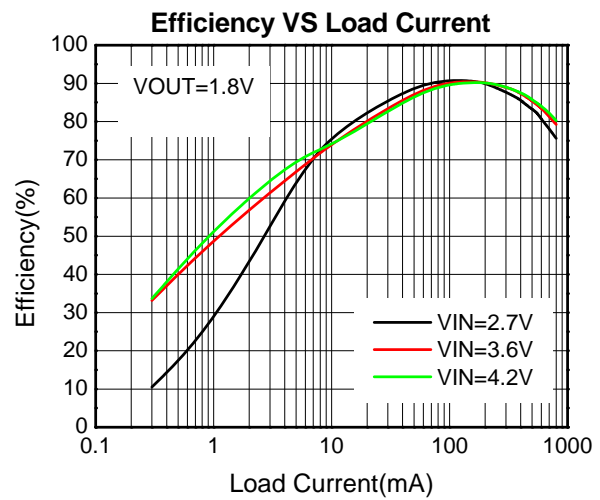
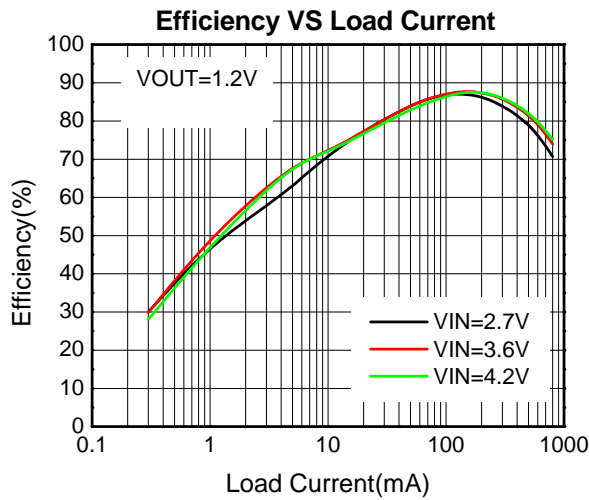

## Typical Performance Characteristics (Continued)

( $V_{IN} = 3.6V$ ,  $V_{OUT} = 1.8V$ ,  $T_A = +25^\circ C$ , unless otherwise noted.)

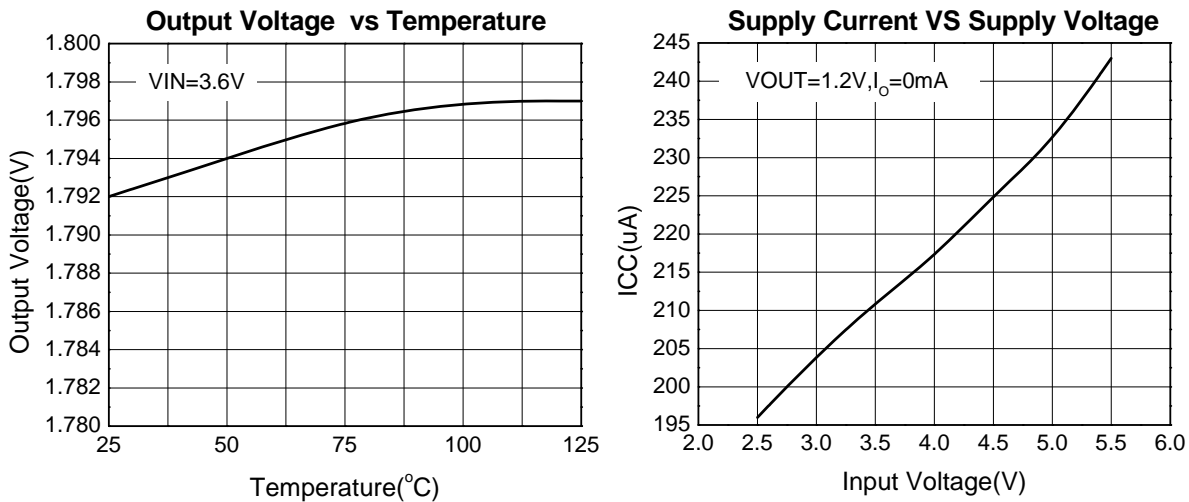

## Applications Information

### Output Voltage Setting

The external resistor divider sets the output voltage. The feedback resistor R1 also sets the feedback loop bandwidth with the internal compensation capacitor.

Choose R1 around 300k $\Omega$  for optimal transient response. R2 is then given by:

$$R2 = \frac{R1}{\frac{V_{OUT}}{0.6V} - 1}$$

### Inductor Selection

A 1 $\mu H$  to 10 $\mu H$  inductor with DC current rating at least 25% higher than the maximum load current is recommended for most applications. For best efficiency, the inductor DC resistance shall be <200m $\Omega$ .

For most designs, the inductance value can be derived from the following equation:

$$L = \frac{V_{OUT} \times (V_{IN} - V_{OUT})}{V_{IN} \times \Delta I_L \times f_{OSC}}$$

Where  $\Delta I_L$  is the inductor ripple current. Choose inductor ripple current approximately 30% of the maximum load current, 600mA.

The maximum inductor peak current is:

$$I_{L(MAX)} = I_{LOAD} + \frac{\Delta I_L}{2}$$

Under light load conditions below 100mA, larger inductance is recommended for improved efficiency.

**Input Capacitor Selection**

The input capacitor reduces the surge current drawn from the input and switching noise from the device. The input capacitor impedance at the switching frequency shall be less than input source impedance to prevent high frequency switching current passing to the input. Ceramic capacitors with X5R or X7R dielectrics are highly recommended because of their low ESR and small temperature coefficients. For most applications, a 4.7 $\mu$ F capacitor is sufficient.

**Output Capacitor Selection**

The output capacitor keeps output voltage ripple small and ensures regulation loop stable. The output capacitor impedance shall be low at the switching frequency. Ceramic capacitor with X5R or X7R dielectrics are recommended. The output ripple  $\Delta V_{OUT}$  is approximately:

$$\Delta V_{OUT} \leq \frac{V_{OUT} \times (V_{IN} - V_{OUT})}{V_{IN} \times f_{OSC} \times L} \times \left( ESR + \frac{1}{8 \times f_{OSC} \times C3} \right)$$

**Layout Guidance**

When laying out the PC board, the following suggestions should be taken to ensure proper operation of the UM3510.

1. The power traces, including the GND trace, the SW trace and the VIN trace should be kept short, direct and wide to allow large current flow. Put enough multiply-layer pads when they need to change the trace layer.
2. Connect the input capacitor C1 to the VIN pin as closely as possible to get good power filter effect.
3. Keep the switching node, SW, away from the sensitive FB node.
4. Do not trace signal line under inductor.

## Package Information

### UM3510: SOT23-5

#### Outline Drawing

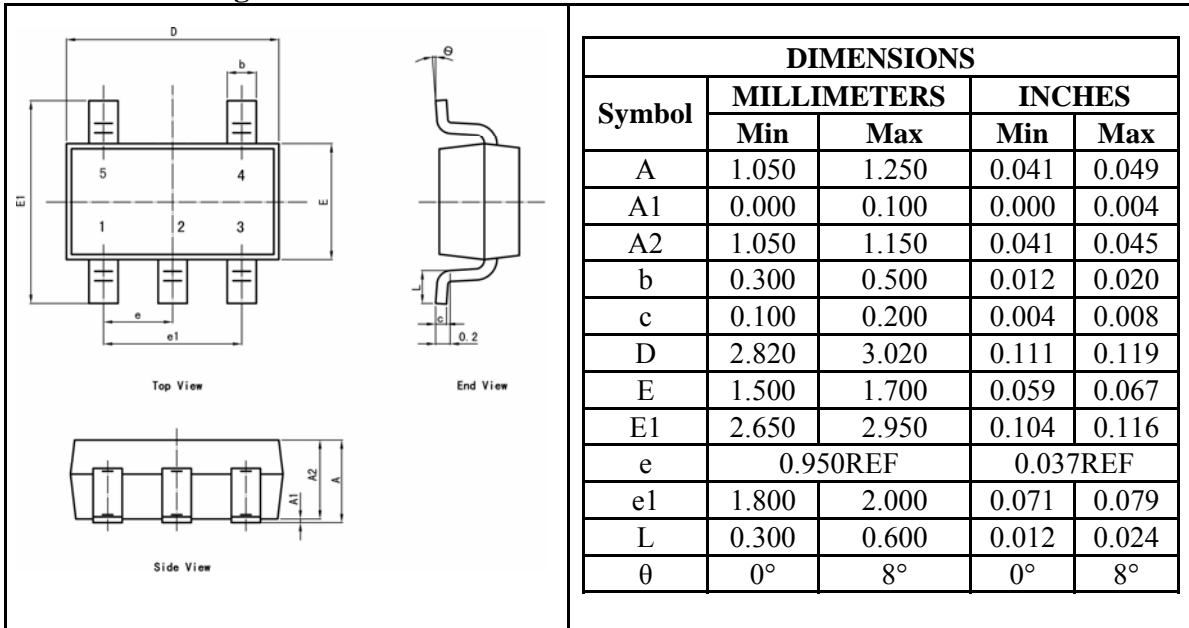

#### Land Pattern

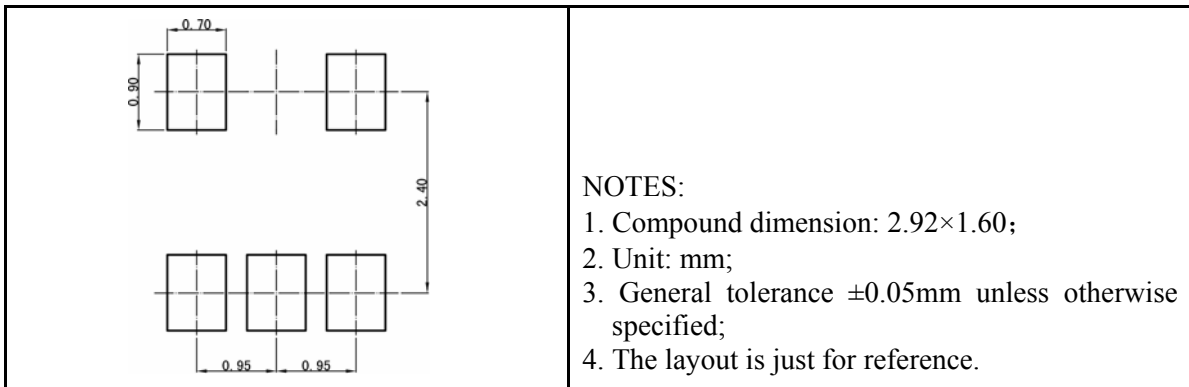

#### Tape and Reel Orientation

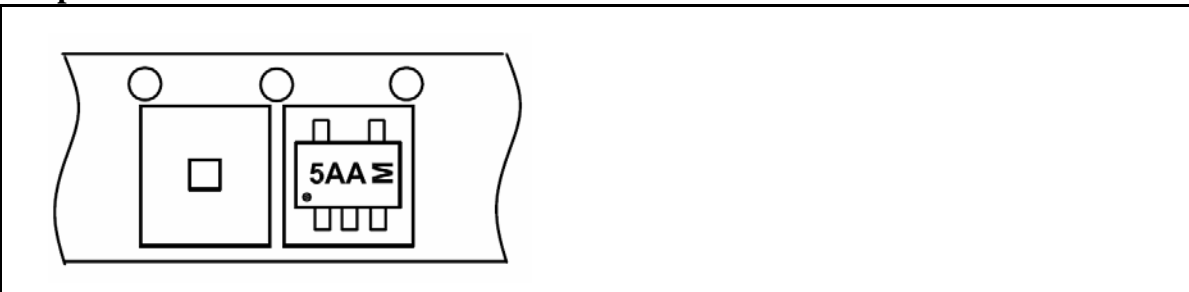

---

**IMPORTANT NOTICE**

The information in this document has been carefully reviewed and is believed to be accurate. Nonetheless, this document is subject to change without notice. Union assumes no responsibility for any inaccuracies that may be contained in this document, and makes no commitment to update or to keep current the contained information, or to notify a person or organization of any update. Union reserves the right to make changes, at any time, in order to improve reliability, function or design and to attempt to supply the best product possible.



Union Semiconductor, Inc

Add: 2F, No. 3, Lane 647 Songtao Road, Shanghai 201203

Tel: 021-51093966

Fax: 021-51026018

Website: [www.union-ic.com](http://www.union-ic.com)