

## 500mA, Micropower, VLDO Linear Regulator

### UM177XX QFN2020-6

#### General Description

The UM177XX series are VLDO (very low dropout) linear regulators designed for low power portable applications. Typical output noise is only  $75\mu\text{V}_{\text{RMS}}$  and maximum dropout is just 400mV at the load current of 500mA. The internal P-channel MOSFET pass transistor requires no base current, allowing the device to draw only  $100\mu\text{A}$  during normal operation at the maximum load current of 500mA.

Other features include high output voltage accuracy, excellent transient response, under voltage lockout, stability with ultra low ESR ceramic capacitors as small as  $1\mu\text{F}$ , reverse-battery, short-circuit and thermal overload protection and output current limiting.

The UM177XX series are available in a low profile QFN2020-6 package.

#### Applications

- Bluetooth/802.11 Cards
- PDAs and Notebook Computers
- Portable Instruments and Battery-Powered Systems
- Cellular Phones

#### Features

- Very Low Dropout: 400mV(max) at 500mA
- Maximum Input Voltage: 6.0V
- Low Noise:  $75\mu\text{V}_{\text{RMS}}$  (10Hz to 100kHz)
- $\pm 2.5\%$  Voltage Accuracy at 500mA
- Fast Transient Response
- Under Voltage Lockout
- Fixed Output Voltage:  
3.5V/3.3V/3.0V/2.8V/2.5V/1.8V/1.5V/1.3V/  
1.2V
- Output Current Limit
- Reverse-Battery Protection
- No Protection Diodes Needed
- Stable with  $1\mu\text{F}$  Output Capacitor
- Short-Circuit and Thermal Overload Protection
- Low Profile QFN2020-6 Package

#### Pin Configurations

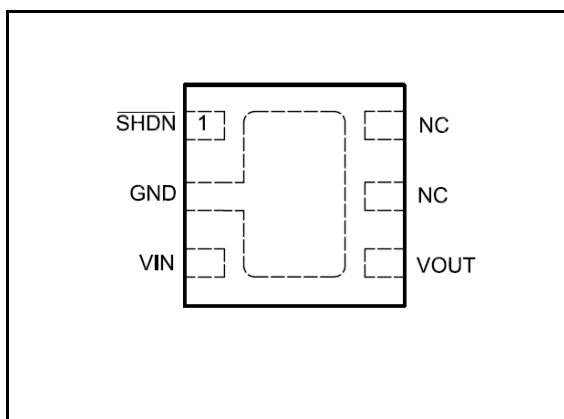

#### Top View

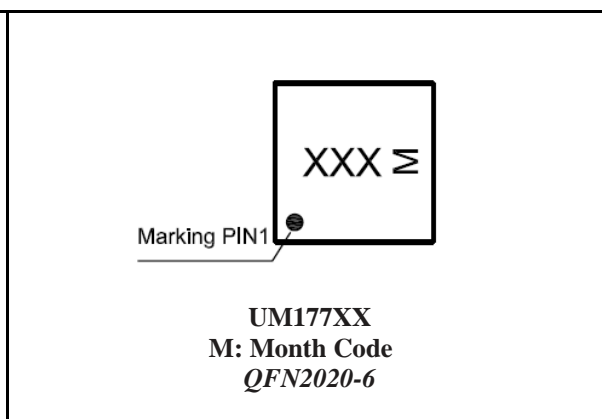

## Ordering Information

Part Number	Output Voltage	Packaging Type	Marking Code	Shipping Qty
UM17735	3.5V	QFN2020-6	AAZ	3000pcs/7Inch Tape & Reel
UM17733	3.3V		AAV	
UM17730	3.0V		AAR	
UM17728	2.8V		AAQ	
UM17725	2.5V		AAN	
UM17718	1.8V		AAK	
UM17715	1.5V		AAJ	
UM17713	1.3V		AAD	
UM17712	1.2V		AAC	

## Pin Description

Pin Number	Symbol	Function
1	$\overline{\text{SHDN}}$	Shutdown Input, Active Low
2	GND	Ground
3	VIN	Power Supply
4	VOUT	Voltage Regulated Output
5	NC	Not Connected
6	NC	Not Connected

## Absolute Maximum Ratings (Note 1)

Symbol	Parameter	Value	Unit
$V_{\text{IN}}$	Supply Voltage on IN Pin	-7.5 to +7.5	V
$V_{\overline{\text{SHDN}}}$	Voltage on $\overline{\text{SHDN}}$ Pin	-0.3 to +7.5	V
$V_{\text{OUT}}$	Voltage on OUT Pin	-0.3 to +7.5	V
	Output Short-Circuit Duration	Indefinite	
$T_{\text{J}}$	Operating Junction Temperature (Notes 2, 3)	-40 to +125	°C
$T_{\text{STG}}$	Storage Temperature Range	-65 to +150	°C
$T_{\text{L}}$	Lead Temperature for Soldering 10 seconds	+300	°C

Note 1: Absolute Maximum Ratings are those values beyond which the life of a device may be impaired.

Note 2: The UM177XX is tested and specified under pulse load conditions such that  $T_{\text{J}} \approx T_{\text{A}}$ . The device is guaranteed to meet performance specifications from 0 °C to 70 °C. Specifications over the -40 °C to 125 °C operating junction temperature range are assured by design, characterization and correlation with statistical process controls.

Note 3: This IC includes overtemperature protection that is intended to protect the device during momentary overload conditions. Junction temperature will exceed 125 °C when overtemperature protection is active. Continuous operation above the specified maximum operating junction temperature may impair device reliability.

**Electrical Characteristics**

Over recommended operating free-air temperature range (unless otherwise noted)

Symbol	Parameter	Test Conditions	Min	Typ	Max	Unit
$V_{IN}$	Input Voltage Range		$V_{OUT}+$ $V_{DROP}$		6.0	V
$V_{UVLO}$	Input Under Voltage Lockout*	$V_{IN}$ falling	2.0		2.6	V
$I_Q$	Operating Quiescent Current	$V_{IN}=5.0V, I_{OUT}=0mA$		90		$\mu A$
		$V_{IN}=5.0V, I_{OUT}=500mA$		100		
$I_{SHDN}$	Shutdown Leakage Current				1	$\mu A$
	ESD Rating	Human Body Mode	2			KV
$I_{OUT}$	Output Current		500			mA
	Output Voltage Accuracy	$1mA \leq I_{OUT} \leq 150mA$ , $T_A = +25^\circ C$	-1		+1	%
		$1mA \leq I_{OUT} \leq 150mA$ , $T_A = -40^\circ C$ to $+85^\circ C$	-2		+2	
		$1mA \leq I_{OUT} \leq 500mA$ , $T_A = -40^\circ C$ to $+85^\circ C$	-2.5		+2.5	
$\Delta V_{DO}$	Dropout Voltage	$I_{OUT}=500mA$		250	400	mV
$I_{LIMIT}$	Output Current Limit	$V_{IN} \geq 2.5V$	700			mA
	Input Reverse Leakage Current (OUT to IN Leakage Current)	$V_{IN}=4V, V_{OUT}=5.5V$ chip active		0.01	1.5	$\mu A$
t	Startup Time Response	$R_L=68\Omega, C_{OUT}=1\mu F$		20		$\mu s$
$V_{IL}$	$\overline{SHDN}$ Input Low Voltage				$0.3 \times V_{IN}$	V
$V_{IH}$	$\overline{SHDN}$ Input High Voltage		$0.7 \times V_{IN}$			V
	$\overline{SHDN}$ Input Current	$\overline{SHDN}=V_{IN}$ or GND	-1	0.1	+1	$\mu A$
$T_{SHDN}$	Thermal-Shutdown Temperature			160		$^\circ C$
$\Delta T_{SHDN}$	Thermal-Shutdown Hysteresis			20		$^\circ C$
	Line Regulation	$V_{OUT}+1V \leq V_{IN} \leq V_{OUT}+2V$ $I_{OUT}=10mA$		0.09		%/V
	Load Regulation	$V_{IN}=V_{OUT}+1V$ $1mA \leq I_{OUT} \leq 150mA$		0.2		%
	Output Voltage Noise	10Hz to 100KHz $C_{IN}=0.1\mu F, I_{OUT}=10mA$		75		$\mu V_{RMS}$
PSRR	Power Supply Ripple Rejection	$V_{IN}=V_{OUT}+1V$ $I_{OUT}=100mA$	F=100Hz	70		dB
			F=1KHz	65		
			F=10KHz	50		
			F=100KHz	40		

\*Only UM17735/UM17733/UM17730/UM17728/UM17725 has this function.

### Typical Characteristics (shown for 3.3 V output option)

(  $C_{IN}=1.0\mu F$ ,  $C_{OUT} = 1.0 \mu F$ ,  $T_A = 25^\circ C$  unless otherwise specified.)

**Figure1. Output Voltage Vs. Input Voltage**

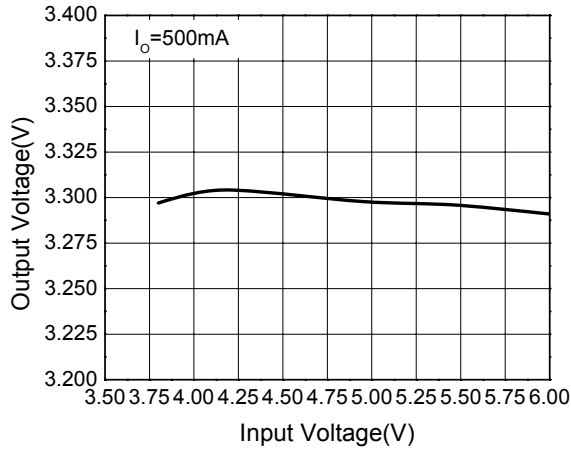

**Figure2. Dropout Voltage Vs. Output Current**

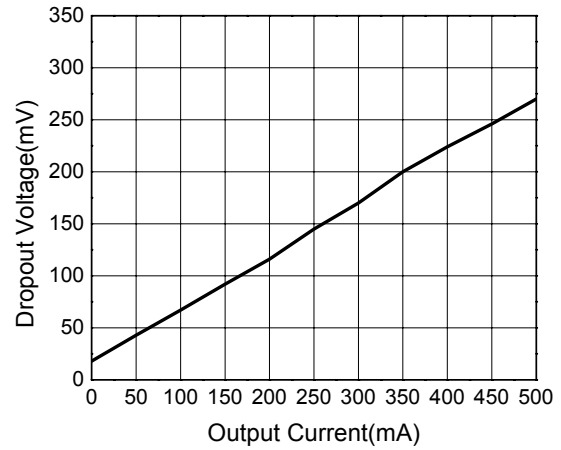

**Figure3. Output Voltage Vs. Temperature**

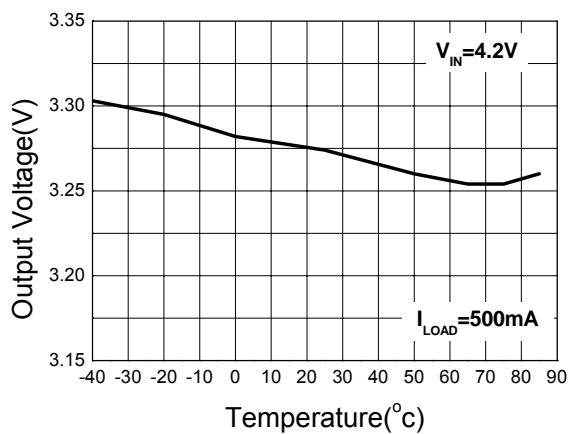

**Figure4. Output Voltage Vs. Output Current**

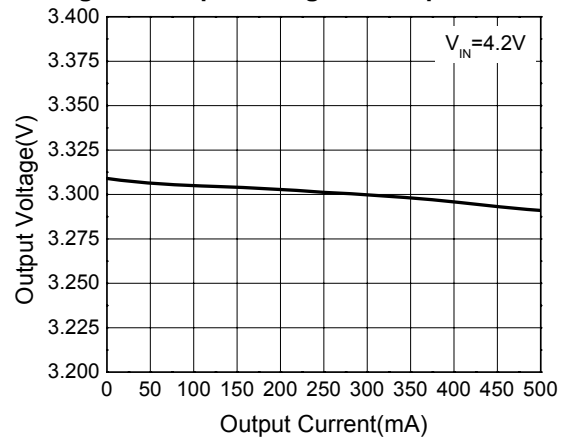

## Pin Function

**$\overline{\text{SHDN}}$  (Pin 1):** Shutdown, Active Low. This pin is used to put the UM177XX into shutdown. The  $\overline{\text{SHDN}}$  pin cannot be left floating and must be tied to the input pin if not used.

**GND (Pin 2):** Ground and Heat Sink. Solder to a ground plane or large pad to maximize heat dissipation.

**VIN (Pin 3):** Power for UM177XX and Load. Power is supplied to the devices through the IN pin. The IN pin should be locally bypassed to ground if the UM177XX series are more than a few inches away from another source of bulk capacitance. In general, the output impedance of a battery rises with frequency, so it is usually advisable to include an input bypass capacitor in battery-powered circuits. A capacitor in the range of  $0.1\mu\text{F}$  to  $1\mu\text{F}$  is usually sufficient. The UM177XX series are designed to withstand reverse voltages on the IN pin with respect to both ground and the output pin. In the case of a reversed input, which can happen if a battery is plugged in backwards, the UM177XX will act as if there is a large resistor in series with its input with only a small amount of current flow.

**VOUT (Pin 4):** Voltage Regulated Output. The OUT pin supplies power to the load. A minimum output capacitor of  $1\mu\text{F}$  is required to ensure stability. Larger output capacitors may be required for applications with large transient loads to limit peak voltage transients. See the Applications Information section for more information on output capacitance.

**NC (Pin 5, 6):** Not Connected.

## Typical Application Circuit

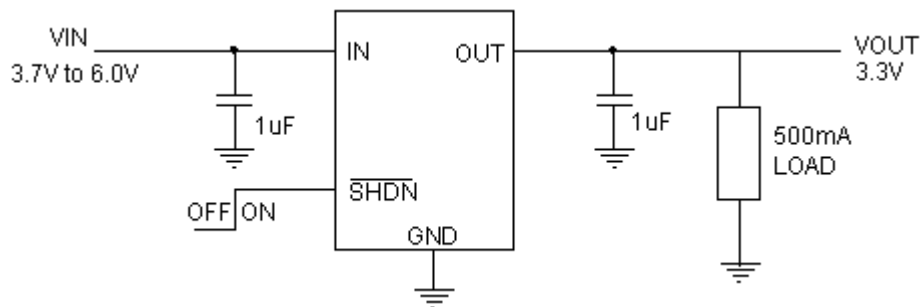

## Package Information

### UM177XX: QFN2020-6

#### Outline Drawing

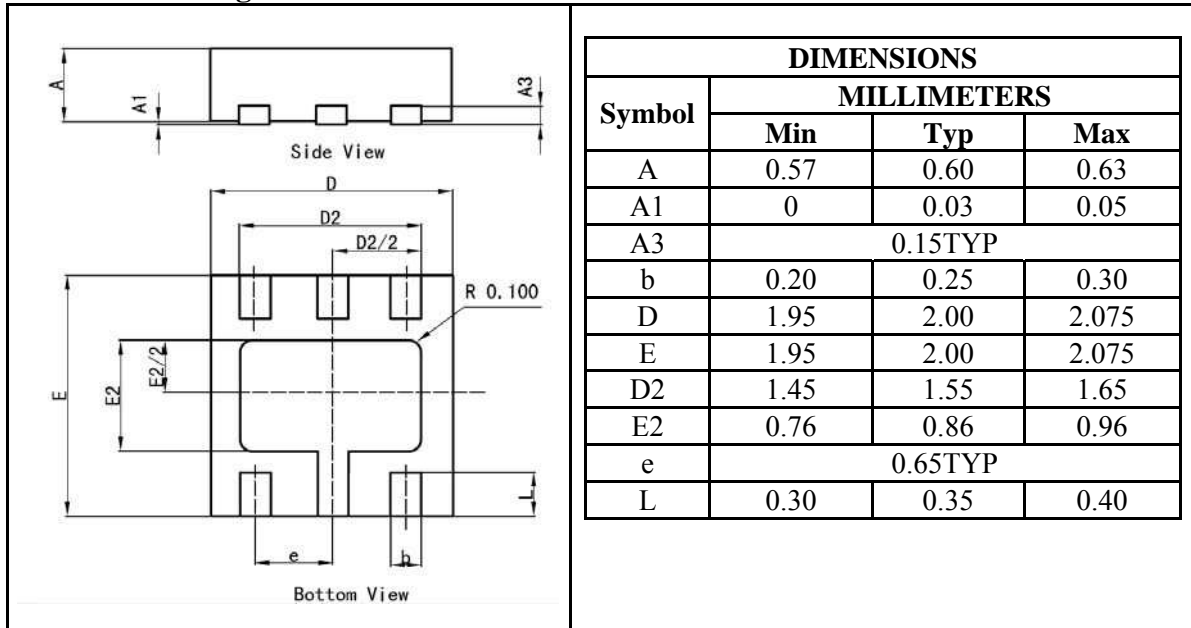

#### Land Pattern

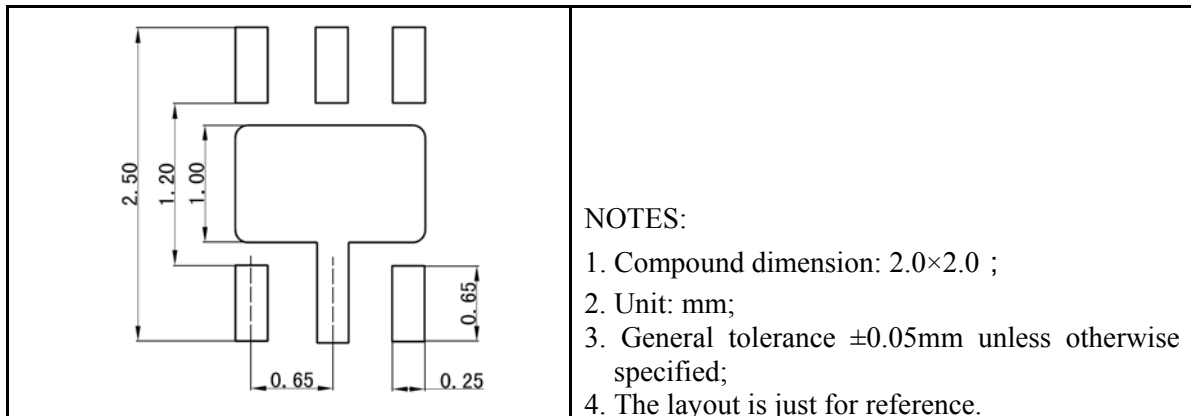

#### Tape and Reel Orientation

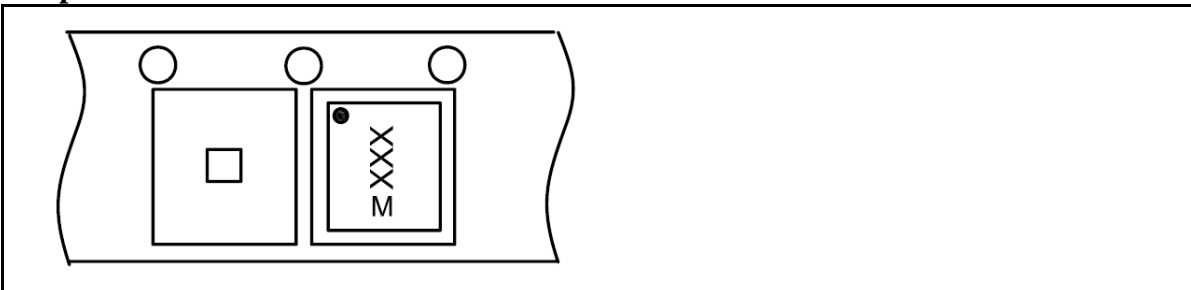

---

**IMPORTANT NOTICE**

The information in this document has been carefully reviewed and is believed to be accurate. Nonetheless, this document is subject to change without notice. Union assumes no responsibility for any inaccuracies that may be contained in this document, and makes no commitment to update or to keep current the contained information, or to notify a person or organization of any update. Union reserves the right to make changes, at any time, in order to improve reliability, function or design and to attempt to supply the best product possible.



Union Semiconductor, Inc

Add: 7F, No. 5, Bibo Road, Shanghai 201203

Tel: 021-51097928

Fax: 021-51026018

Website: [www.union-ic.com](http://www.union-ic.com)