



DESCRIPTION

The PT2463 is a motor driver designed for 2 phase stepping motor, it implement PWM to regulate output current. The driver stage is consists by dual MOSFET H-bridge. Fabricated by advanced BCD process to improve performance and reduce power losses. The driver support up to 40V supply voltage and maximum driving current up to 1.8A.

The on-chip voltage regulator allows only powered from a single power supply, VM, it highly reduce external components and saving the PCB size.

FEATURES

- Low $R_{DS(on)}$ BCD process
- PWM constant-current drive
- Provides phase inputs to allow full step and half step excitation
- High voltage and current: 40V/1.8A
- Thermal shutdown (TSD), over-current shutdown (ISD), power-on reset (POR) and under voltage lock out (UVLO) helps to secure operates status.
- HTSSOP 28-Pin package with thermal pad

APPLICATIONS

- Home appliance
- Amusement machine
- Office automation machine

BLOCK DIAGRAM

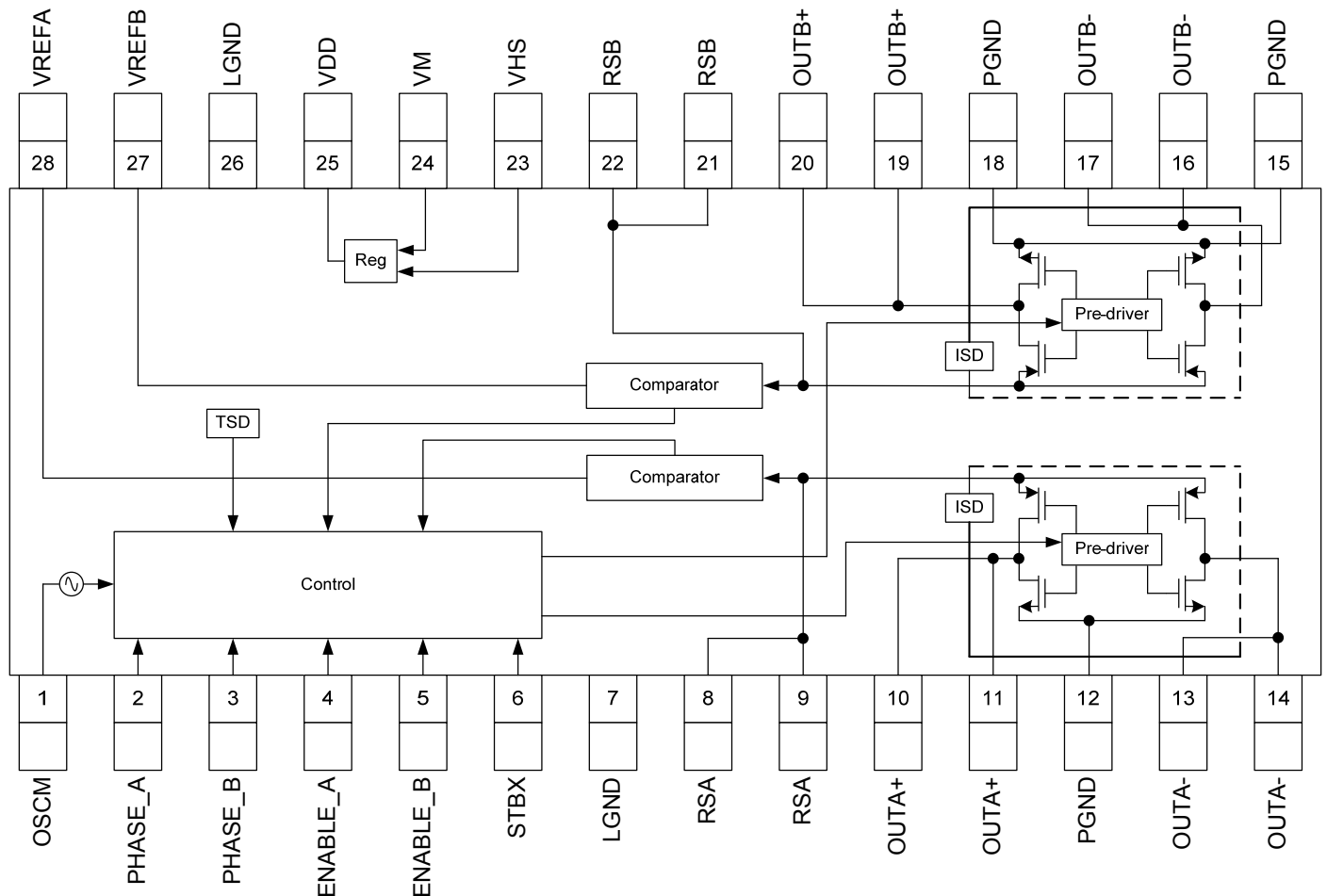



APPLICATION CIRCUIT DIAGRAM

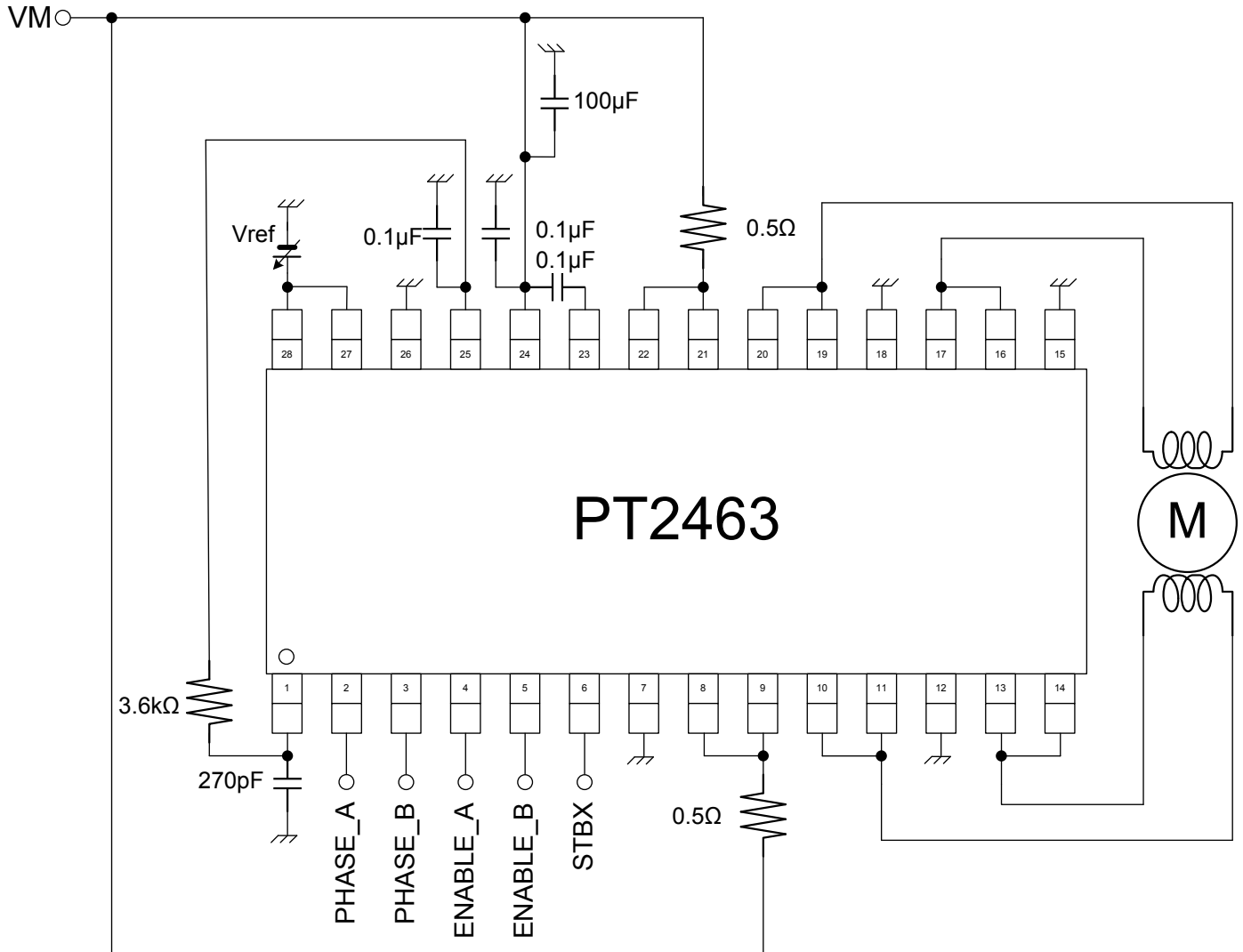



ORDER INFORMATION

Part Number	Package Type	Top Code
PT2463-HT	28-Pin, HTSSOP, 173MIL	PT2463-HT

PIN CONFIGURATION

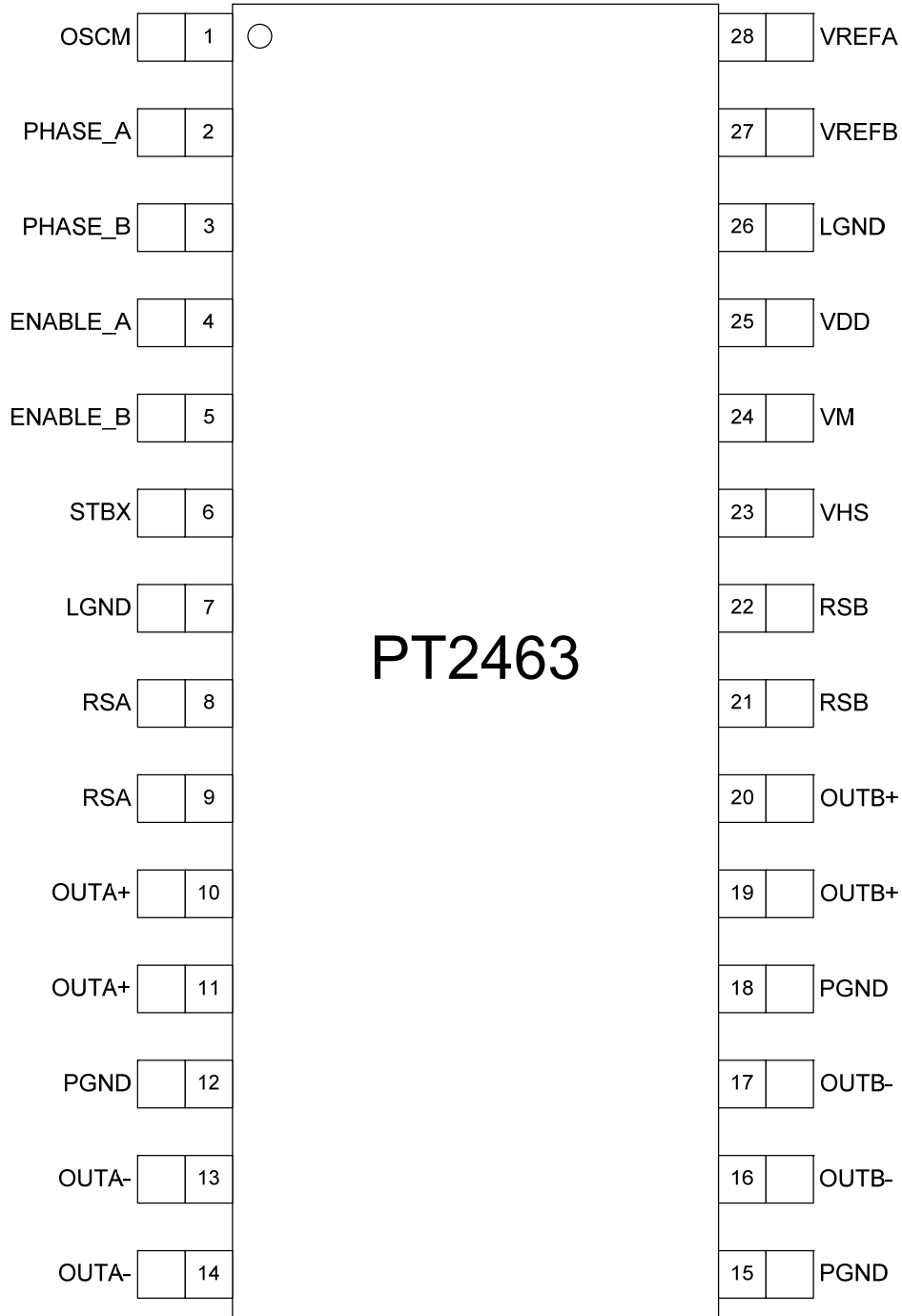

PIN DESCRIPTION

Pin Name	I/O	Description	Pin No.
OSCM	I/O	External pin for system clock RC oscillator	1
PHASE_A	I	Phase-A output current direction select	2
PHASE_B	I	Phase-B output current direction select	3
ENABLE_A	I	Phase-A enable, high=driver on, GND=driver off.	4
ENABLE_B	I	Phase-B enable, high=driver on, GND=driver off.	5
STBX	I	Power down mode; connect to GND will disable OSCM and output driver.	6
LGND	-	GND for logic circuit	7, 26
RSA	I	External current sense resistor A; connect to high side of H-bridge, also the negative input of current sense circuit.	8, 9
OUTA+	O	H-bridge driver A positive output	10, 11
PGND	-	H-bridge driver A GND	12
OUTA-	O	H-bridge driver A negative output	13, 14
PGND	-	H-bridge driver B GND	15
OUTB-	O	H-bridge driver B negative output	16, 17
PGND	-	Power GND	18
OUTB+	O	H-bridge driver B positive output	19, 20
RSB	I	External current sense resistor B; connect to high side of H-bridge, also the negative input of current sense circuit.	21, 22
VHS	O	Smoothing filter for built-in regulator for high side driver	23
VM	-	Main supply for the motor, also the positive input of current sense circuit.	24
VDD	I	Smoothing filter for built-in regulator for logic	25
VREFB	I	Apply a DC potential to determinate output peak current of the PHASE B driver	27
VREFA	I	Apply a DC potential to determinate output peak current of the PHASE A driver	28

IMPORTANT NOTICE

Princeton Technology Corporation (PTC) reserves the right to make corrections, modifications, enhancements, improvements, and other changes to its products and to discontinue any product without notice at any time.

PTC cannot assume responsibility for use of any circuitry other than circuitry entirely embodied in a PTC product. No circuit patent licenses are implied.

Princeton Technology Corp.
2F, 233-1, Baociao Road,
Sindian, Taipei 23145, Taiwan
Tel: 886-2-66296288
Fax: 886-2-29174598
<http://www.princeton.com.tw>