

DESCRIPTION

The PT5102P is a 1-channel low-saturation bi-directional motor driver IC. The design is optimal for motor applications, such as cameras, printers, FDDs, or other portable devices with forward, reverse, brake and stand-by function.

FEATURES

- H-Bridge drive, low ON resistance (Upper transistor + low transistor resistance: 1.3Ω typ. At 200mA , $V_{DD} = V_M = 3.3V$)
- Low input current
- Built in Over current protection circuit (OCP)
- Built in Under voltage lockout circuit (UVLO)
- Brake function
- High output sinking and driving capability
- Thin, highly reliable package (MSOP-8)

BLOCK DIAGRAM & APPLICATION CIRCUIT

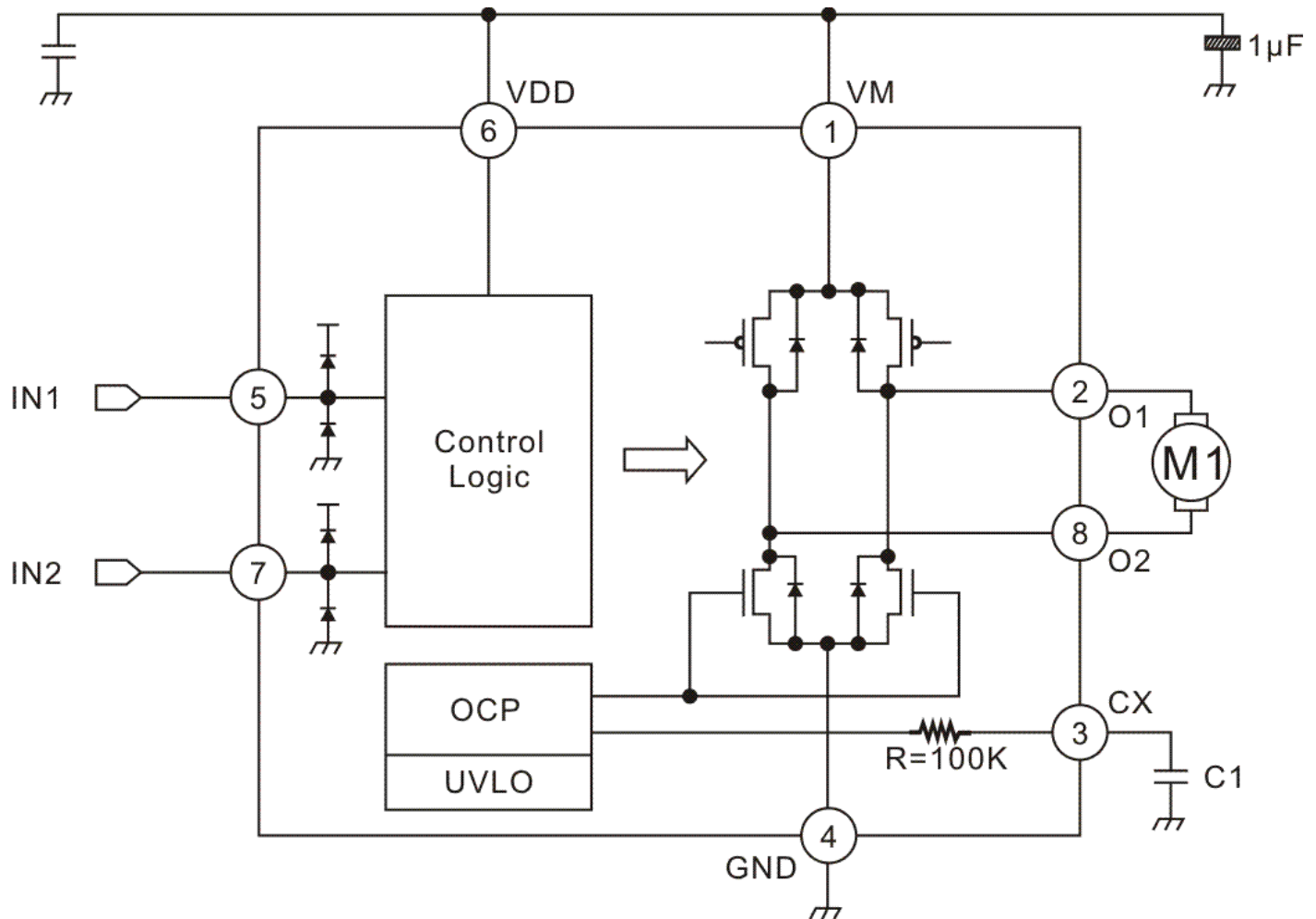

ORDER INFORMATION

Valid Part Number	Package Type	Top Code
PT5102P	8 Pins, MSOP, 118MIL	PT5102P

PIN CONFIGURATION

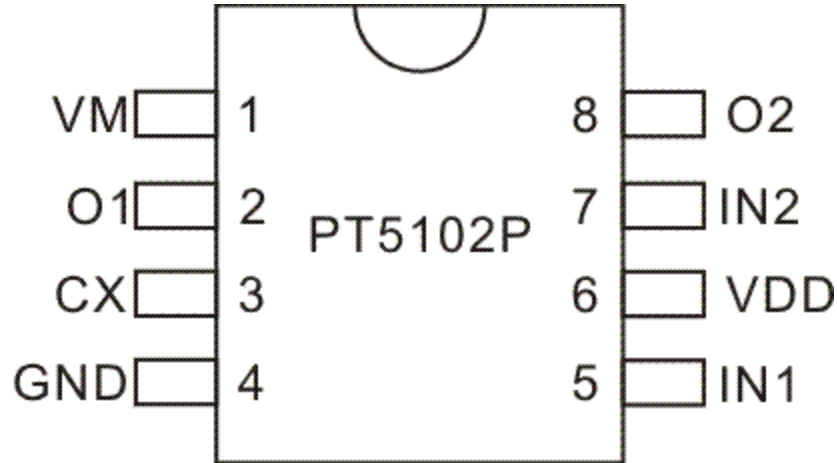

PIN DISCRIPTION

Pin Name	Description	Pin No.
VM	Power supply pin for output driver	1
O1	Output sinking / driving pin	2
CX	Capacitance terminal for start inrush current	3
GND	Ground pin	4
IN1	Input pin that determines driving mode	5
VDD	Power supply pin for controller.	6
IN2	Input pin that determines driving mode	7
O2	Output sinking / driving pin	8