

DESCRIPTION

The PT5115 is a monolithic 4-Channel CMOS H-bridge motor driver. It can drive one stepper motor, two DCM and two coils. There also are several other flexible system solutions left to be utilized. The current consumption can be hold at quite low level during standby or operation. And the active power supply voltage range is from 2.7~5.5V. So the device is ideal for portable and battery powered applications.

The PT5115 is available in QFN24 (4mm × 4mm) package. Performance is specified for -20°C to +85°C temperature range.

APPLICATIONS

- DSC

FEATURES

- Independent 4channel H-bridge, 3 full-swing drivers and 1 constant-current driver, all of those drivers with brake function.
- Versatile and flexible control mode - DC/stepper motor alternative, Full-swing/ Constant-Voltage/ Constant-Current selected
- Special Exclusive Control mode optional
- Constant-Voltage set by DAC: 1.8V~4.8V 0.2V/Bit Accuracy ± 5%
- Constant current set by DAC: 150mV~300mV 10mV/Bit Accuracy±5%
- Under voltage lockout circuit - Shut down the internal circuit at VCC=1.8V (Typ.)
- Thermal shut down circuit - Shut down the internal circuit at 150°C Hysteresis 30°C
- Available in small package QFN24 (4mm × 4mm)

BLOCK DIAGRAM

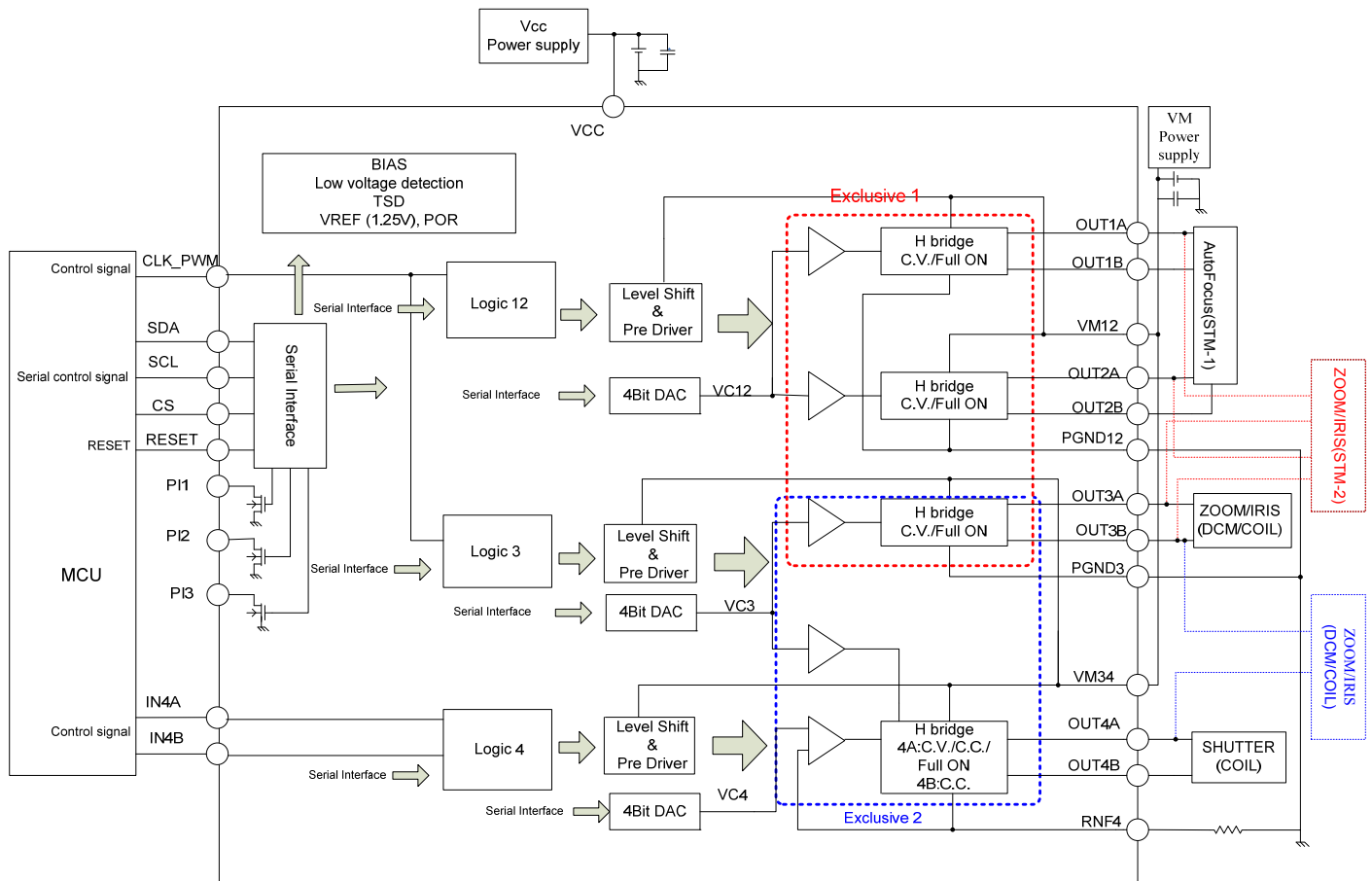

Notes:

1. FS=Full-swing
2. CV= Constant-Voltage
3. CC=Constant-Current

ORDER INFORMATION

| Valid Part Number | Package Type | Top Code |
|-------------------|--------------|----------|
| PT5115 | 24 pins, QFN | PT5115 |

PIN CONFIGURATION

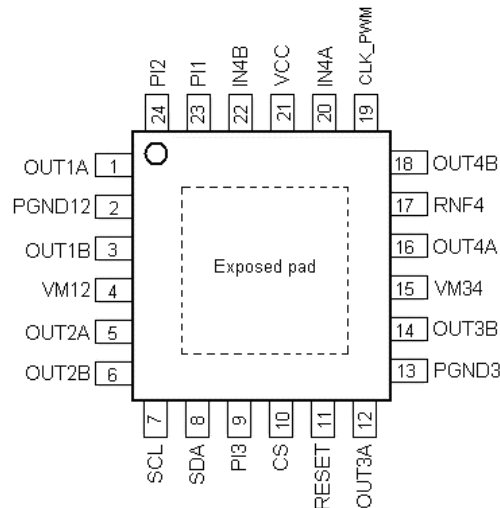

Note: The Exposed PAD must be connect to GND

PIN DESCRIPTION

| Pin Name | I/O | Description | Pin No. |
|-----------|--------------|---|-------------|
| OUT1A | O | CH1 output A | 1 |
| PGND12 | GND | CH12 Power GND | 2 |
| OUT1B | O | CH1 output B | 3 |
| VM12 | Power Supply | CH1/2 Power supply | 4 |
| OUT2A | O | CH2 output A | 5 |
| OUT2B | O | CH2 output B | 6 |
| SCL | I | Serial clock input | 7 |
| SDA | I | Serial data input | 8 |
| PI3 | OUT | PI3 Output | 9 |
| CS | I | Serial data latch control | 10 |
| RESET | I | Logic reset | 11 |
| OUT3A | O | CH3 output A | 12 |
| PGND3 | GND | CH3 Power GND | 13 |
| OUT3B | O | CH3 output B | 14 |
| VM34 | Power Supply | CH3/4 Power supply | 15 |
| OUT4A | O | CH4 output A | 16 |
| RNF4 | I/O | CH4 current sense input or Power GND | 17 |
| OUT4B | O | CH4 output B | 18 |
| CLK_PWM | I | Stepping motor clock for CH12/PWM input for CH3 | 19 |
| IN4A | I | CH4 Input Control Pin | 20 |
| VCC | Power Supply | Small signal power supply | 21 |
| IN4B | I | CH4 Input Control Pin | 22 |
| PI1 | OUT | PI1 Output | 23 |
| PI2 | OUT | PI2 Output | 24 |
| PGND3/GND | GND | CH3 Power GND and pre driver GND | Exposed pad |

IMPORTANT NOTICE

Princeton Technology Corporation (PTC) reserves the right to make corrections, modifications, enhancements, improvements, and other changes to its products and to discontinue any product without notice at any time.

PTC cannot assume responsibility for use of any circuitry other than circuitry entirely embodied in a PTC product. No circuit patent licenses are implied.

Princeton Technology Corp.
2F, 233-1, Baociao Road,
Sindian, Taipei 23145, Taiwan
Tel: 886-2-66296288
Fax: 886-2-29174598
<http://www.princeton.com.tw>