

FEATURES

- An ultra-fine CMOS process has been adopted for low power consumption in a design with no charge-pump.
- A small 24-pin QFN package (4*4mm / t=0.8mmMax / Lead pitch 0.4mm) has been adopted.
- All bridges can be driven simultaneously.
- Constant-Voltage control H-bridges Drive; Accuracy±5%(at CV DAC=4.0V)
- Constant-Current H-bridges Drive; Accuracy±5%(at CC DAC=200mV)
- A constant voltage value and a constant current value are set as arbitrary values by serial setup (4-bit).
- External resistance is unnecessary in order to change by Built-in DAC.
- Built-in thermal shutdown circuit.(shut: 150°C/return: 120°C/Hysteresis: 30°C)
- Built-in UVLO shutdown circuit.(shut: 1.8V/return: 2.0V/Hysteresis: 0.2V)
- Built-in CC mode weak excitation
- H-Bridge Drive Type/ON Resistance
 - CH1~3: CV/FS Ron=1.3Ω(TYP) at VM=5V, I=100mA (600mA MAX)
 - CH4: CC/CV/FS Ron=1.3Ω(TYP) at VM=5V, I=100mA (600mA MAX)
 - CH5: CC/Ron=1.3Ω(TYP) at VM=5V, I=100mA (600mA MAX)
- DAC
 - 4-bit composition
 - 1~4CH Constant-Voltage: 1.8~4.8V, 0.2V/bit
 - 4~5CH Constant-Current: 150~300mV, 10mV/bit
- Recommend Operating Condition
 - Power-supply voltage range: VCC: 2.7~3.6V, VM: 2.7~ 5.5V
 - Rated power-supply voltage: VCC: 3.3V, VM: 5.0V

BLOCK DIAGRAM

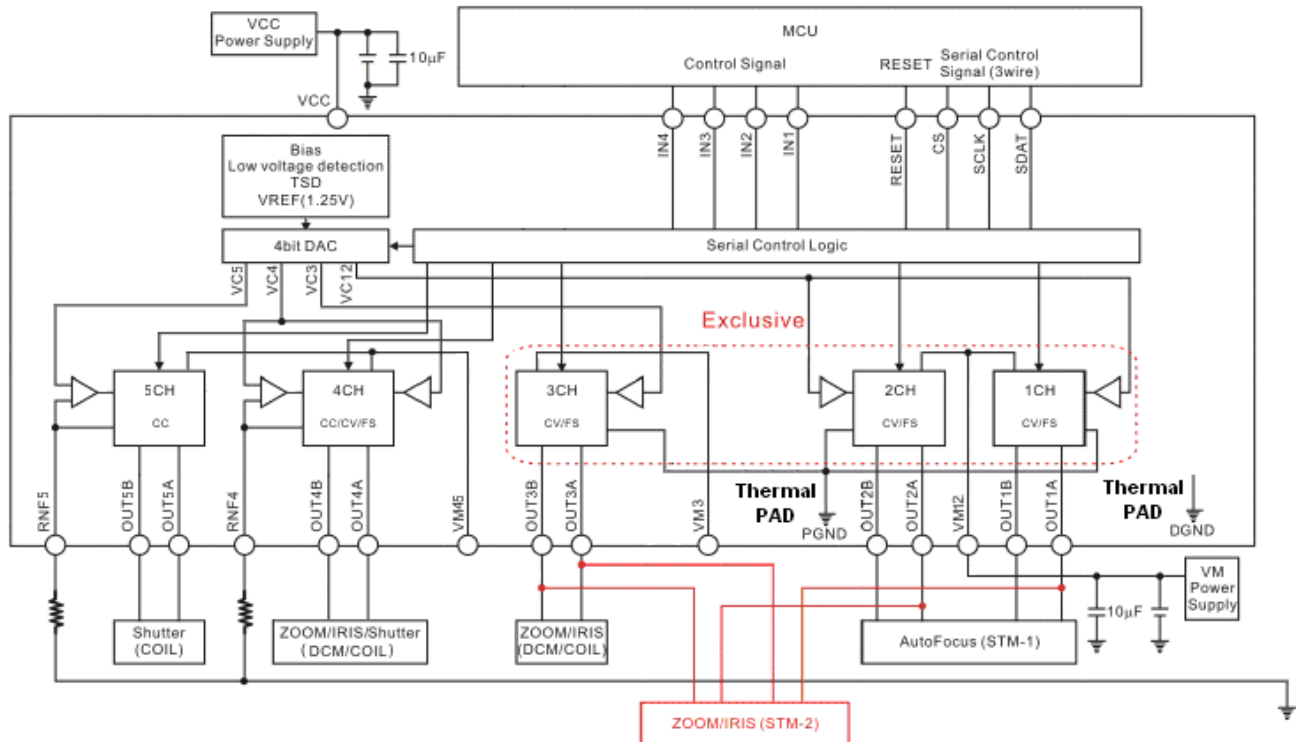

Notes:

1. FS=Full-Swing
2. CV=Constant-Voltage
3. CC=Constant-Current

ORDER INFORMATION

Valid Part Number	Package Type	Top Code
PT5113-QF	24 Pins, QFN	PT5113

PIN CONFIGURATION

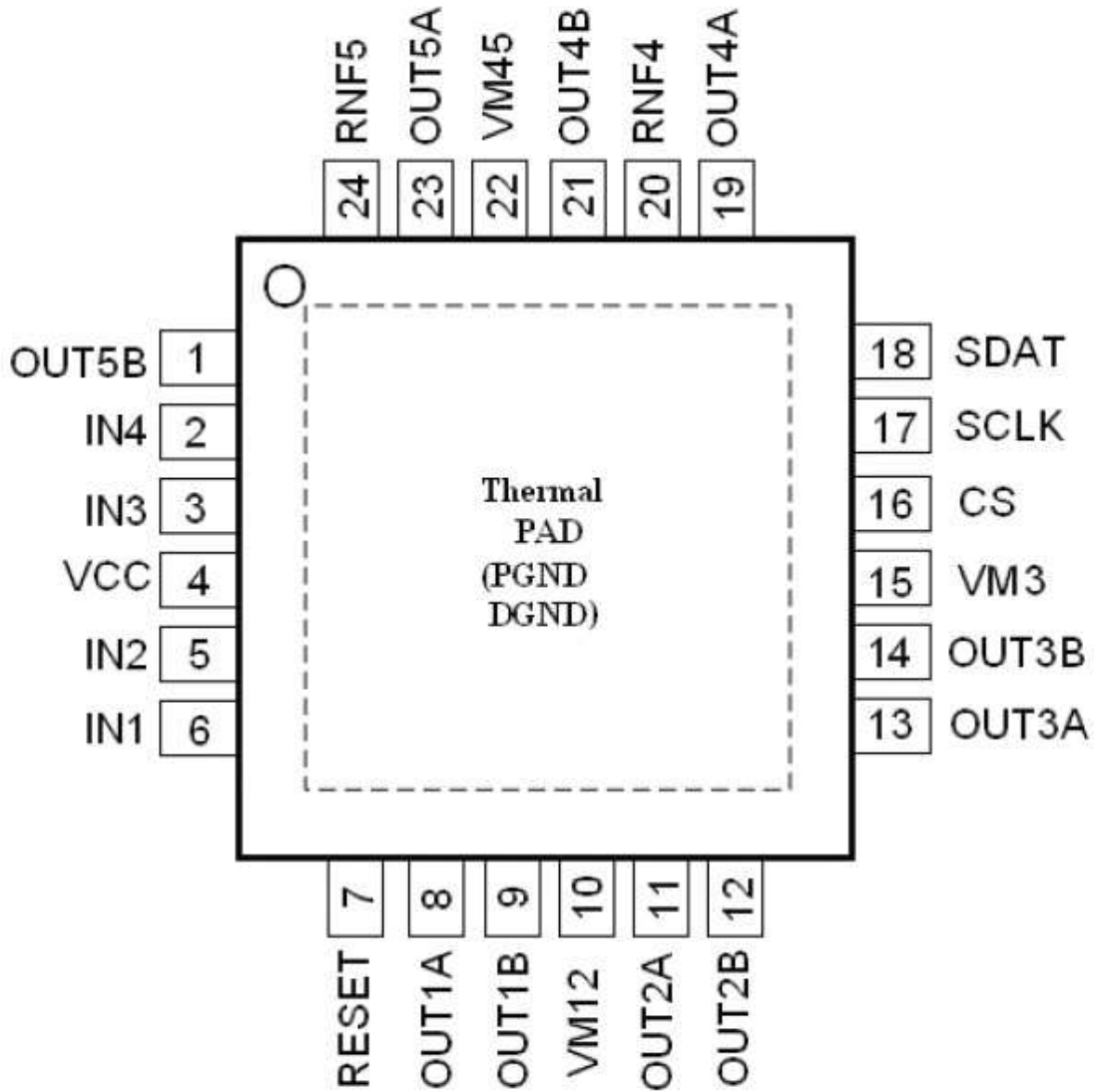

PIN DESCRIPTION

Pin Name	I/O	Description	Pin No.
OUT5B	O	CH5 output B	1
IN4	I	Parallel input signal	2
IN3	I	Parallel input signal	3
VCC	Power Supply	Small signal power supply	4
IN2	I	Parallel input signal	5
IN1	I	Parallel input signal	6
RESET	I	Logic reset	7
OUT1A	O	CH1 output A	8
OUT1B	O	CH1 output B	9
VM12	Power Supply	CH1/2 Power supply	10
OUT2A	O	CH2 output A	11
OUT2B	O	CH2 output B	12
OUT3A	O	CH3 output A	13
OUT3B	O	CH3 output B	14
VM3	Power Supply	CH3 Power supply	15
CS	I	Serial data latch control	16
SCLK	I	Serial clock input	17
SDAT	I	Serial data input	18
OUT4A	O	CH4 output A	19
RNF4	I/O	CH4 current sense input	20
OUT4B	O	CH4 output B	21
VM45	Power Supply	CH4/5 Power supply	22
OUT5A	O	CH5 output A	23
RNF5	I/O	CH5 current sense input	24
Thermal PAD	GND	CH1/2 Power GND and CH3 Power GND	Bottom
Thermal PAD	GND	Small signal power GND	Bottom

IMPORTANT NOTICE

Princeton Technology Corporation (PTC) reserves the right to make corrections, modifications, enhancements, improvements, and other changes to its products and to discontinue any product without notice at any time.

PTC cannot assume responsibility for use of any circuitry other than circuitry entirely embodied in a PTC product. No circuit patent licenses are implied.

Princeton Technology Corp.
2F, 233-1, Baociao Road,
Sindian, Taipei 23145, Taiwan
Tel: 886-2-66296288
Fax: 886-2-29174598
<http://www.princeton.com.tw>