

## DESCRIPTION

PT6913A/B is a special current regulator to drive HV LED. Few external components design is very flexible in many compact size applications. The simple driving topology will improve power factor, efficiency. EMI issue will be avoided with this linear control.

PT6913A/B supports maximum 400V input voltage that ensures the high reliability for HV LED lighting. LED open/short is protected by PT6913A/B. The high voltage will be absorbed by PT6913A/B itself. LEDs will never face high voltage problem.

PT6913A/B also provides temperature attenuation function. When internal junction temperature is higher than 130°C, PT6913A/B will decrease the output current linearly. The output current will be zero when internal junction temperature reaches 150°C. This protection method effectively avoids the flicker problem during abnormal environment temperature.

## FEATURES

- 5V~400V Operating Voltage
- 5~60mA Programmable Output Current
- $\pm 5\%$  Current Accuracy
- Parallel Using for High Current Application
- High Power Factor
- High Efficiency
- Few External Components
- Electrical Capacitor Needless
- LED Open/Short Protection
- Temperature Attenuation
  - When  $T_j > 130^\circ\text{C}$ , output current will be decreased.
  - Output current will be zero when  $T_j = 150^\circ\text{C}$
- SOT89-3 Package
- TO252-3 Package

## APPLICATIONS

- LED Bulb
- LED Tube Lamp
- Compact Size LED Lighting

## BLOCK DIAGRAM

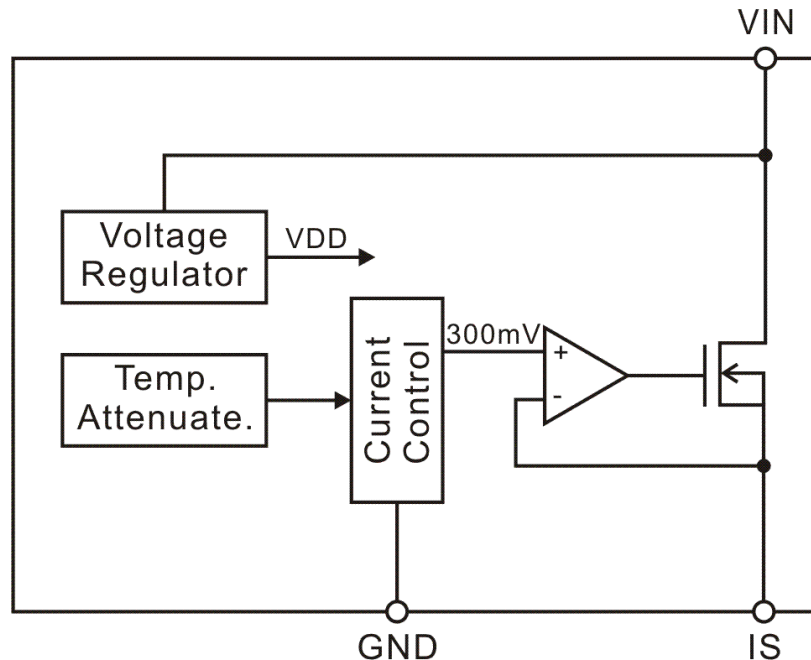

# TYPICAL APPLICATION

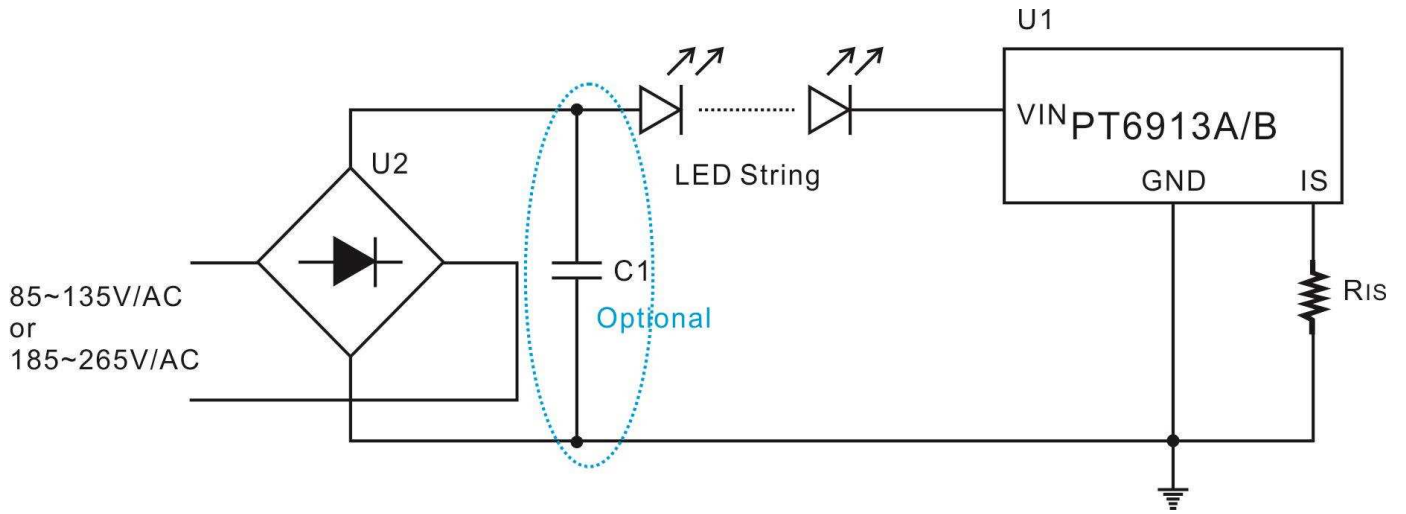

Normal Constant Current Regulator for HV LED

## ORDER INFORMATION

Valid Part Number	Eco Plan	Package Type	Top Code
PT6913A	Green(RoHS & no Sb/Br)	SOT89-3	PT6913A
		TO252-3	
PT6913B	Pb-Free	SOT89-3	PT6913B
		TO252-3	

## PIN CONFIGURATION

### PT6913A/B

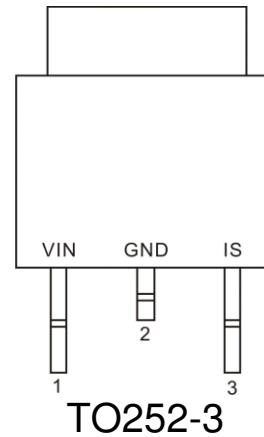
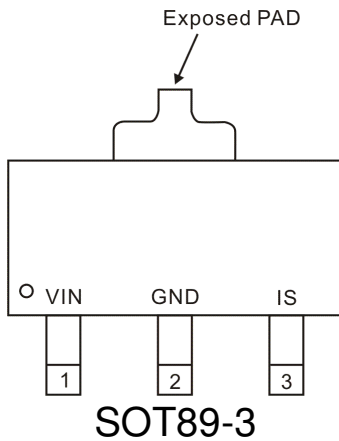

## PIN DESCRIPTION

Pin Name	Description	Pin No.	
		SOT89-3	TO252-3
VIN	IC Power Supply.	1	1
GND	IC Ground.	2	2
IS	Output Current Setting. The output current is programmable by a resistor across IS pin and IC GND pin.	3	3

## **FUNCTION DESCRIPTION**

### **OPERATION**

As shown in the typical application, the PT6913A/B is series with LED string. The PT6913A/B operates in linear mode, It absorbs the extra voltage and controls constant output current. The maximum 400V operating voltage can cover most AC applications and provides higher reliability.

### **OUTPUT CURRENT**

The output current is set by the resistor across IS and GND. If input voltage is enough larger than output voltage, it can be calculated as following equation.

$$I_{LED} = \frac{300mV}{R_{IS}}$$

### **TEMPERATURE ATTENUATION**

The PT6913A/B integrates temperature attenuation function. When the junction temperature is higher than 130°C typically, the reference voltage of IS will decreased by 15mV/°C, which causes the output current decreases too. Normally, the output current will be zero if the junction temperature rises up to 150°C.

This function is useful when environment temperature is abnormal high. PT6913A/B will try to reduce the environment temperature by reducing the LED current. The temperature will be balanced at some level if the abnormal condition is not removed. The device will be protected and flicker doesn't happen.

### **LED SHORT PROTECTION**

The worst case is LED shorted with two terminals. PT6913A/B will try to regulate constant current. The voltage across PT6913A/B will be very high. The junction temperature of PT6913A/B will increase by higher power dissipation. It will work into temperature attenuation mode. It means that LED short protection is realized by temperature attenuation.

## ABSOLUTE MAXIMUM RATINGS

Parameter	Symbol	Rating	Unit	
VIN to GND	-	-0.3~+600	V	
IS to GND	-	-0.3~+0.5	V	
Maximum Output Current	I <sub>OUT</sub>	80	mA	
Operating Temperature Range	T <sub>OPR</sub>	-40~+105	°C	
Storage Temperature Range	T <sub>STG</sub>	-40~+150	°C	
Continuous Power Dissipation(Ta=25°C)	SOT89-3	P <sub>TOT</sub>	1.0	W
	TO252-3	P <sub>TOT</sub>	1.8	W

## ELECTRICAL CHARACTERISTICS

(Unless otherwise specified, Ta=25°C)

Parameter	Symbol	Conditions	Min.	Typ.	Max.	Unit
Input Supply Voltage	V <sub>IN</sub>		5.0	-	400	V
Input Active Current	I <sub>AC</sub>	V <sub>IN</sub> =30V, IS Floating	-	220	-	µA
IS Voltage	V <sub>IS</sub>	V <sub>IN</sub> =30V, R <sub>IS</sub> =1KΩ	285	300	315	mV
IS Voltage Line Regulation	ΔV <sub>IS</sub>	V <sub>IN</sub> =5~30V, R <sub>IS</sub> =1KΩ	-	-	1	%
Output Current Range	I <sub>OUTR</sub>		5		60	mA
Temperature Attenuation Trigger Threshold	T <sub>TRIG</sub>		-	130	-	°C
Temperature Attenuation Coefficient of IS Voltage after T <sub>TRIG</sub>	K <sub>T</sub>		-	-15	-	mV/°C

## TYPICAL PERFORMANCE CHARACTERISTICS

(Unless otherwise specified, Ta=25°C)

Input Active Current vs V<sub>IN</sub>

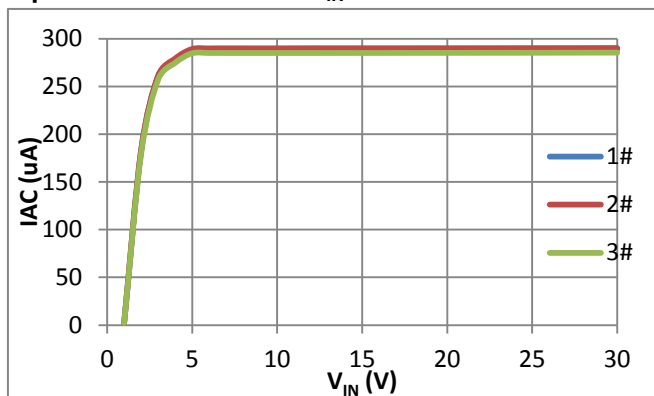

Output Current vs V<sub>IN</sub> @ I<sub>OUT\_MAX</sub>=60mA

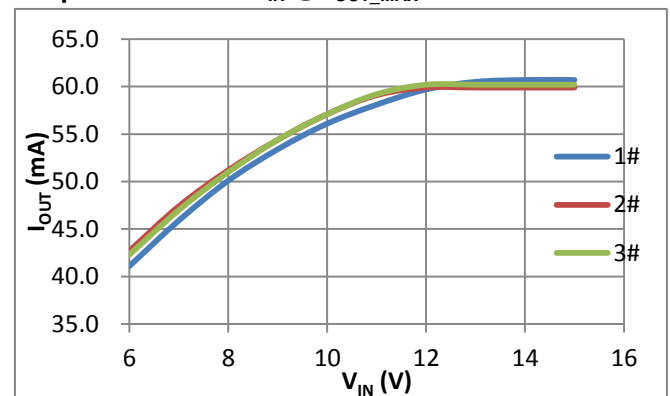

# PACKAGE INFORMATION

## SOT89-3

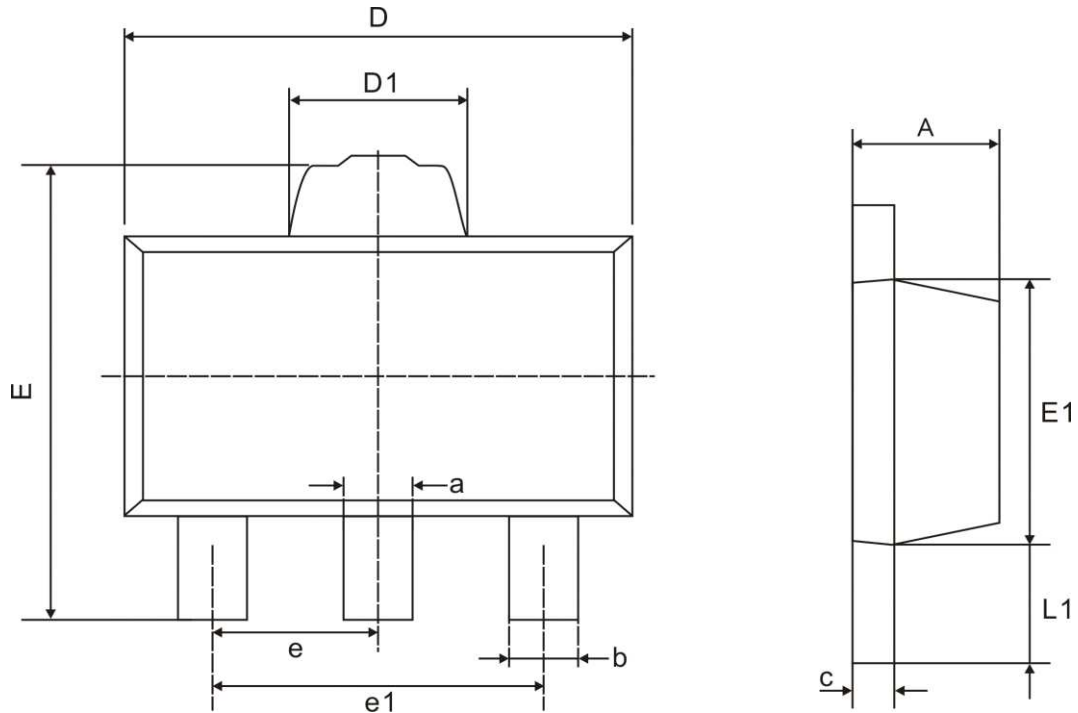

Symbol	Dimensions (mm)		
	Min	Nom	Max
A	1.40	1.50	1.60
b	0.38	-	0.47
c	0.40	-	0.45
a	0.46	-	0.55
D	4.30	4.50	4.71
D1	1.70 REF		
E	4.00	4.20	4.40
E1	230	2.50	2.70
e	1.500 REF		
e1	2.90	-	3.10
L1	0.80	1.00	1.20

TO252-3

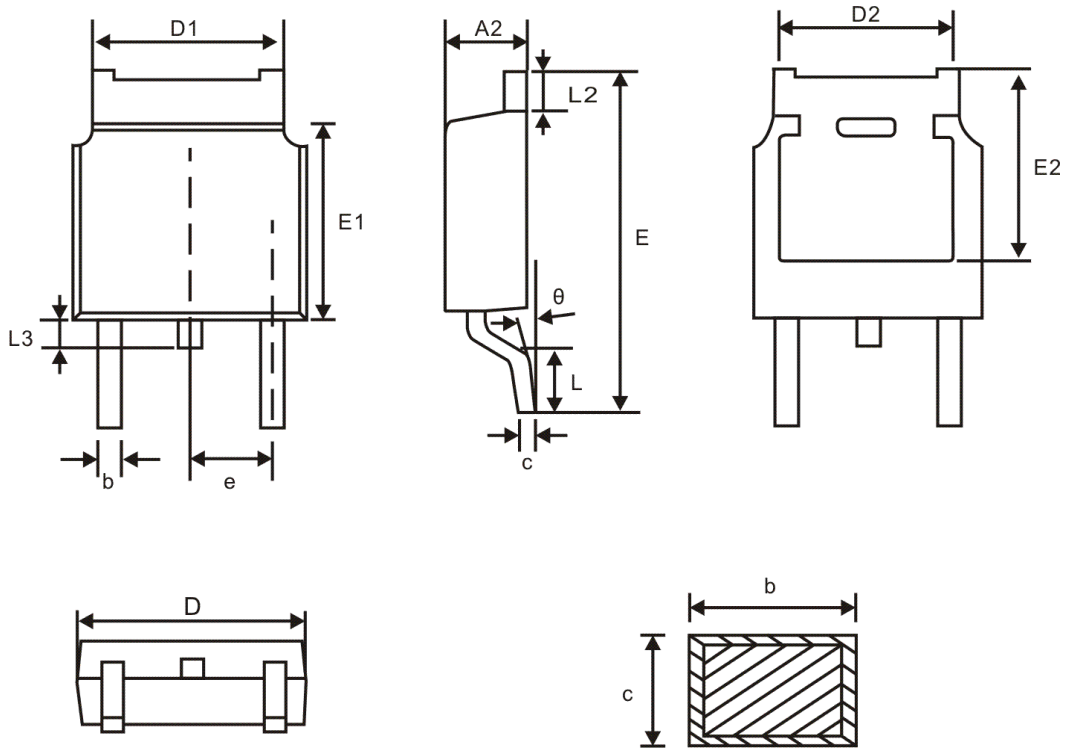

Symbol	Dimensions (mm)		
	Min	Nom	Max
A1	0	-	0.10
A2	2.20	2.30	2.40
b	0.75	-	0.84
c	0.49	-	0.57
D	6.50	6.60	6.70
D1	5.334 REF.		
D2	4.70	4.826	4.92
E	9.90	10.10	10.30
E1	6.00	6.10	6.20
E2	5.30 REF.		
e	2.286 BSC.		
L	1.40	1.50	1.60
L2	0.90	-	1.25
L3	0.60	0.80	1.00
$\theta$	0°	-	8°

## **IMPORTANT NOTICE**

Princeton Technology Corporation (PTC) reserves the right to make corrections, modifications, enhancements, improvements, and other changes to its products and to discontinue any product without notice at any time. PTC cannot assume responsibility for use of any circuitry other than circuitry entirely embodied in a PTC product. No circuit patent licenses are implied.

Princeton Technology Corp.  
2F, 233-1, Baociao Road,  
Sindian Dist., New Taipei City 23145, Taiwan  
Tel: 886-2-66296288  
Fax: 886-2-29174598  
<http://www.princeton.com.tw>