

DESCRIPTION

PT6959 is an LED Controller driven on a 1/4 to 1/7 duty factor. Fourteen to eleven segment output lines, 4 to 7 grid output lines, one display memory, control circuit are all incorporated into a single chip to build a highly reliable peripheral device for a single chip microcomputer. Serial data is fed to PT6959 via a three-line serial interface. Housed in a 28-pin SOP, PT6959's pin assignments and application circuit are optimized for easy PCB Layout and cost saving advantages.

FEATURES

- CMOS technology
- Low power consumption
- 8-step dimming circuitry
- Serial interface for clock, data input, strobe pins
- Available in 28-pin, SOP

APPLICATION

- Microcomputer peripheral devices

BLOCK DIAGRAM

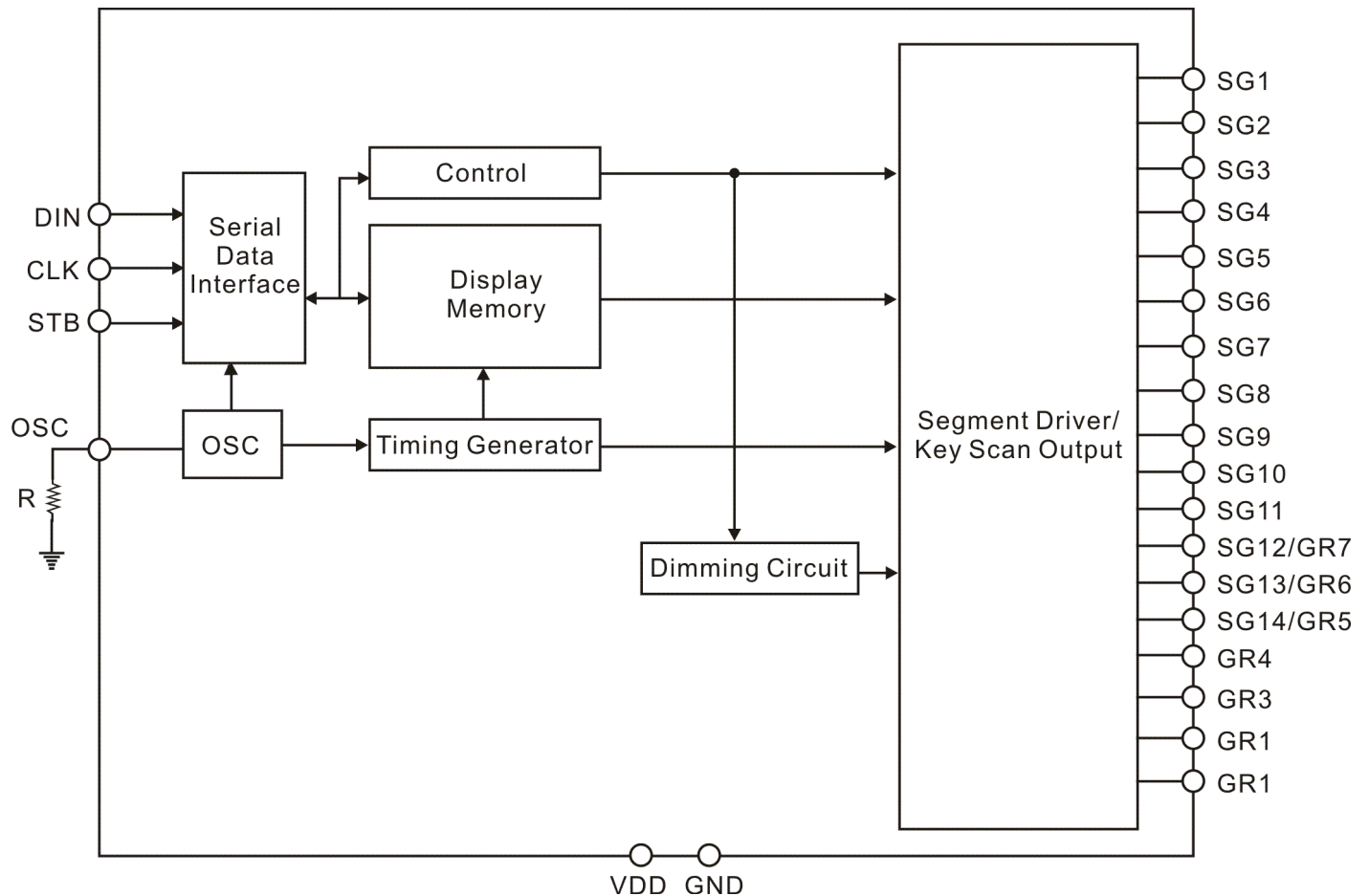

APPLICATION CIRCUIT

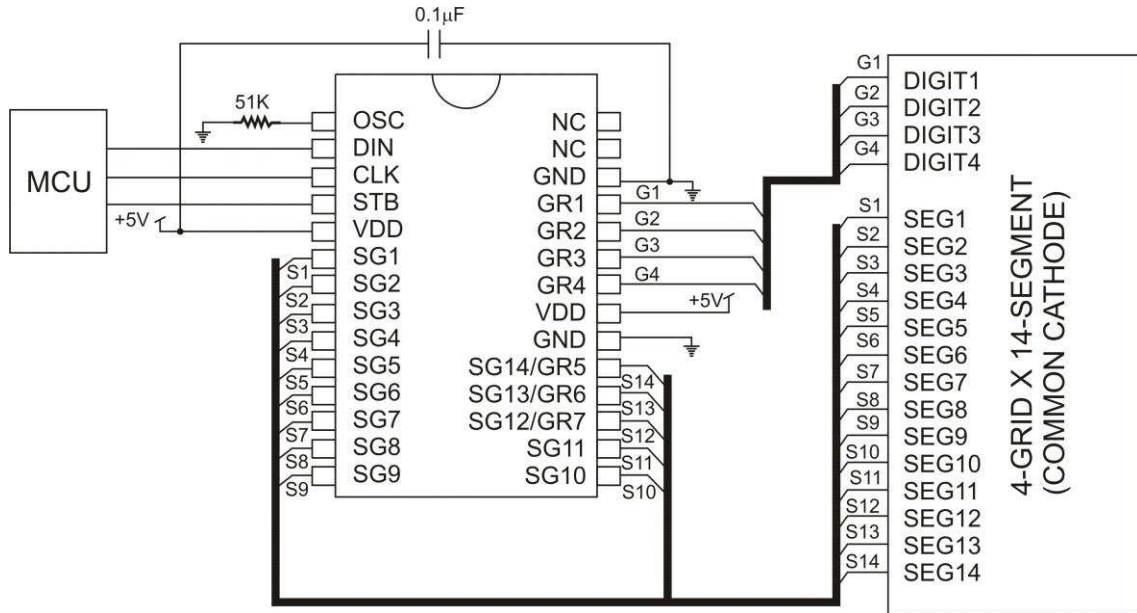

Notes:

1. The capacitor (0.1µF) connected between the GND and VDD Pins must be located as near as possible to the PT6959 chip.
2. The PT6959 power supply is separate from the application system power supply.

COMMON CATHODE TYPE LED PANEL

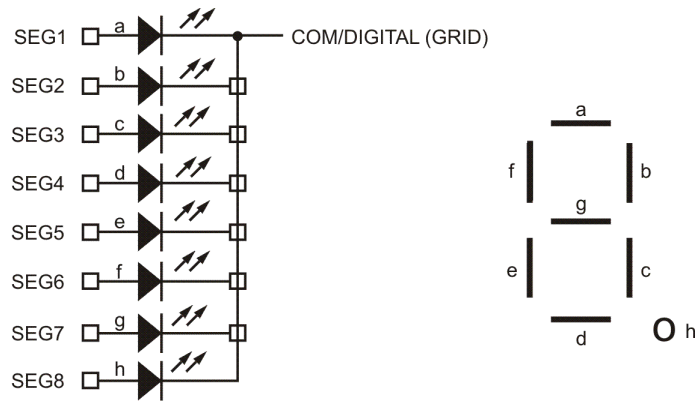

ORDER INFORMATION

Valid Part Number	Package Type	Top Code
PT6959-S	28-pin, SOP, 300mil	PT6959-S

PIN CONFIGURATION

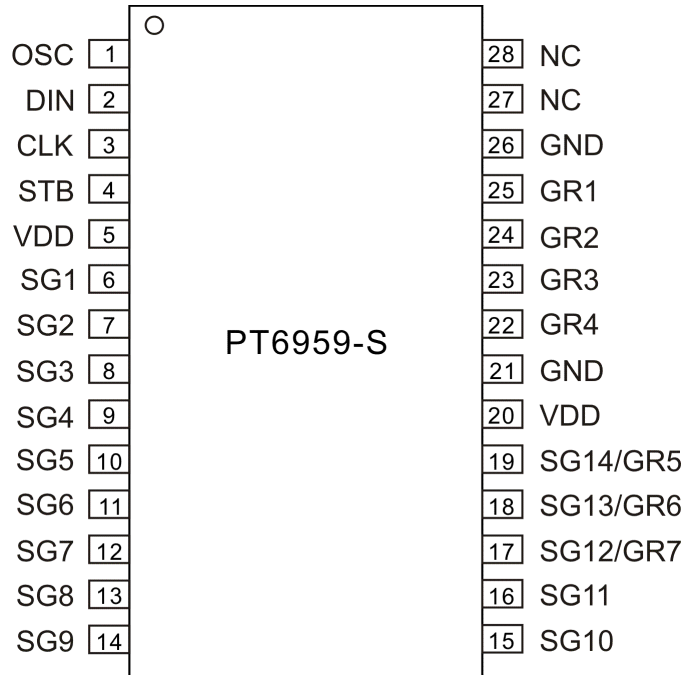

PIN DESCRIPTION

Pin Name	I/O	Description	Pin No.
OSC	I	Oscillator input pin A resistor is connected to this pin to determine the oscillation frequency.	1
DIN	I	Data input pin This pin inputs serial data at the rising edge of the shift clock (starting from the lower bit).	2
CLK	I	Clock input pin This pin reads serial data at the rising edge.	3
STB	I	Serial interface strobe pin The data input after the STB has fallen is processed as a command. When this pin is "HIGH", CLK is ignored.	4
VDD	-	Power supply	5, 20
SG1 ~ SG11	O	Segment output pins (p-channel, open drain)	6 ~ 16
SG12/GR7 ~ SG14/GR5	O	Segment output pin/Grid output pin (CMOS output)	17 ~ 19
GND	-	Ground pin	21, 26
GR4 ~ GR1	O	Grid output pins (n-channel, open drain)	22 ~ 25
NC	-	No connection	27, 28

INPUT/OUTPUT CONFIGURATIONS

The schematic diagrams of the input and output circuits of the logic section are shown below.

Input Pins: CLK, STB & DIN

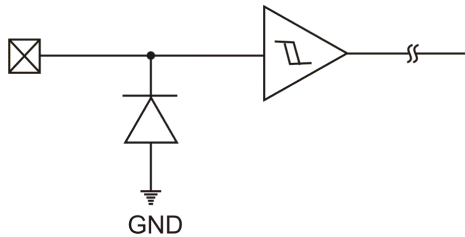

Output Pins: SG14/GR5 to SG12/GR7

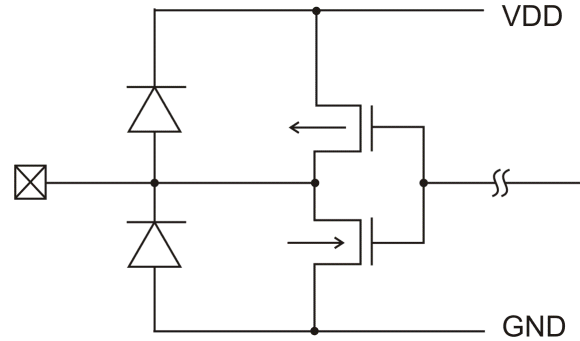

Output Pins: GR1 to GR4

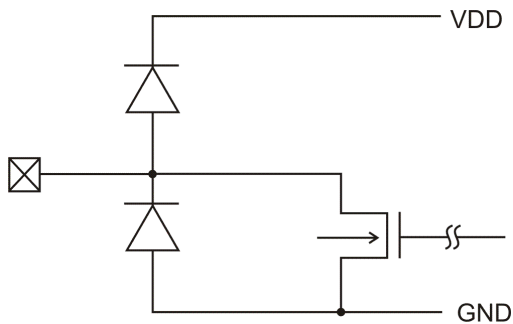

Output Pins: SG1 to SG11

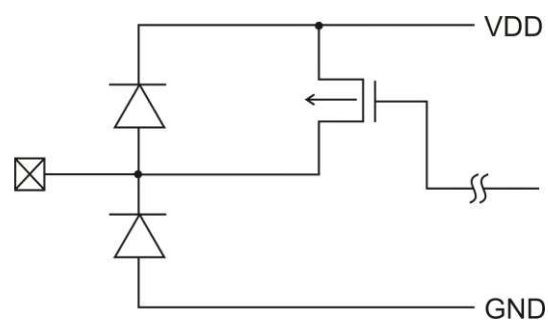

FUNCTION DESCRIPTION

COMMANDS

A command is the first byte (b0 to b7) inputted to PT6959 via the DIN Pin after STB Pin has changed from “HIGH” to “LOW” State. If for some reason the STB Pin is set to “HIGH” while data or commands are being transmitted, the serial communication is initialized, and the data/commands being transmitted are considered invalid.

COMMAND 1: DISPLAY MODE SETTING COMMANDS

PT6959 provides 4 display mode settings as shown in the diagram below: As stated earlier a command is the first one byte (b0 to b7) transmitted to PT6959 via the DIN Pin when STB is “LOW”. However, for these commands, Bit No. 3 to Bit No.6 (b2 to b5) are ignored, Bit No. 7 & Bit No. 8 (b6 to b7) are given a value of “0”.

The Display Mode Setting Commands determine the number of segments and grids to be used (1/4 to 1/7 duty, 14 to 11 segments). When these commands are executed, the display is forcibly turned off. A display command “ON” must be executed in order to resume display. If the same mode setting is selected, no command execution is take place, therefore, nothing happens.

When Power is turned “ON”, the 7-Grid, 11-Segment Mode is selected.

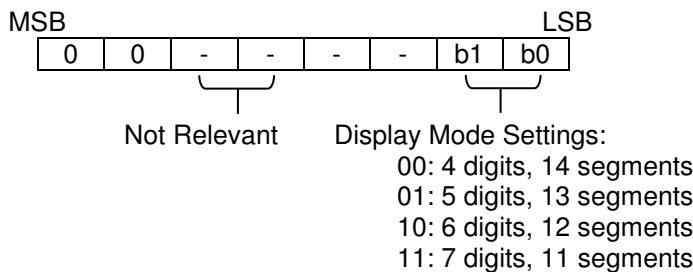

COMMAND 2: DATA SETTING COMMANDS

The Data Setting Commands executes the Data Write Mode for PT6959. The Data Setting Command, the bits 5 and 6 (b4, b5) are ignored, bit 7 (b6) is given the value of “1” while bit 8 (b7) is given the value of “0”. Please refer to the diagram below.

When power is turned ON, bit 4 to bit 1 (b3 to b0) are given the value of “0”.

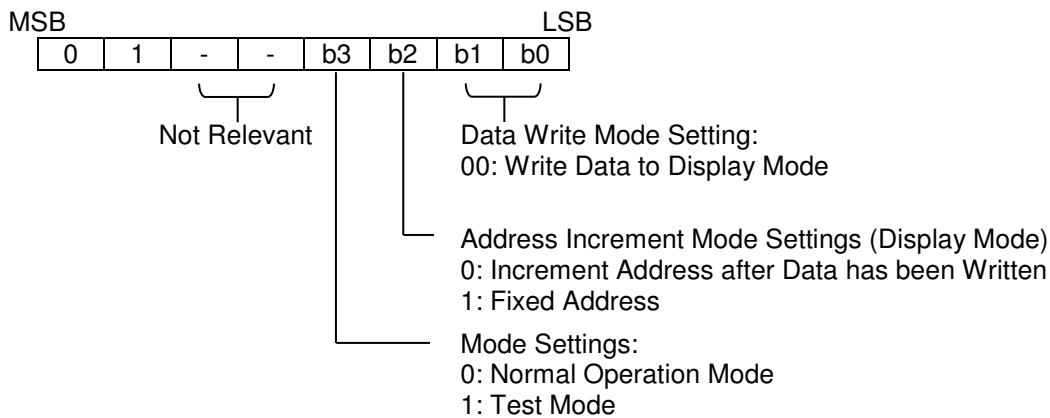

COMMAND 3: ADDRESS SETTING COMMANDS

Address Setting Commands are used to set the address of the display memory. The address is considered valid if it has a value of "00H" to "0DH". If the address is set to "0EH" or higher, the data is ignored until a valid address is set. When power is turned ON, the address is set at "00H".

Please refer to the diagram below.

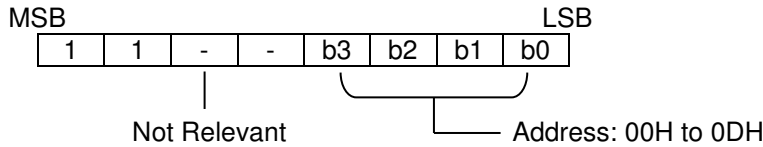

Display Mode and RAM Address

Data transmitted from an external device to PT6959 via the serial interface are stored in the Display RAM and are assigned addresses. The RAM Addresses of PT6959 are given below in 8 bits unit.

SG1	SG4	SG5	SG8	SG9	SG12	SG13	SG14	
00HL		00HU			01HL		01HU	DIG1
02HL		02HU			03HL		03HU	DIG2
04HL		04HU			05HL		05HU	DIG3
06HL		06HU			07HL		07HU	DIG4
08HL		08HU			09HL		09HU	DIG5
0AHL		0AHU			0BHL		0BHU	DIG6
0CHL		0CHU			0DHL		0DHU	DIG7

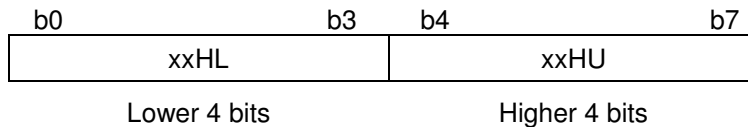

COMMAND 4: DISPLAY CONTROL COMMANDS

The Display Control Commands are used to turn ON or OFF a display. It also used to set the pulse width. Please refer to the diagram below. When the power is turned ON, a 1/16 pulse width is selected and the displayed is turned OFF.

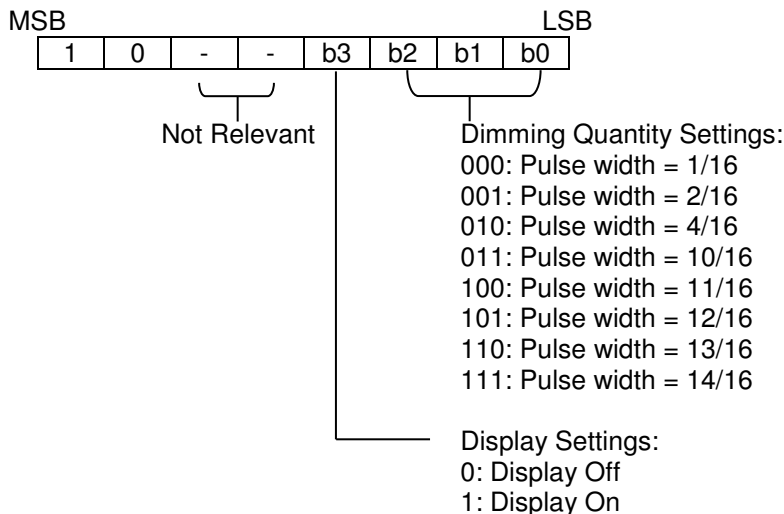

DISPLAY TIMING WAVEFORM

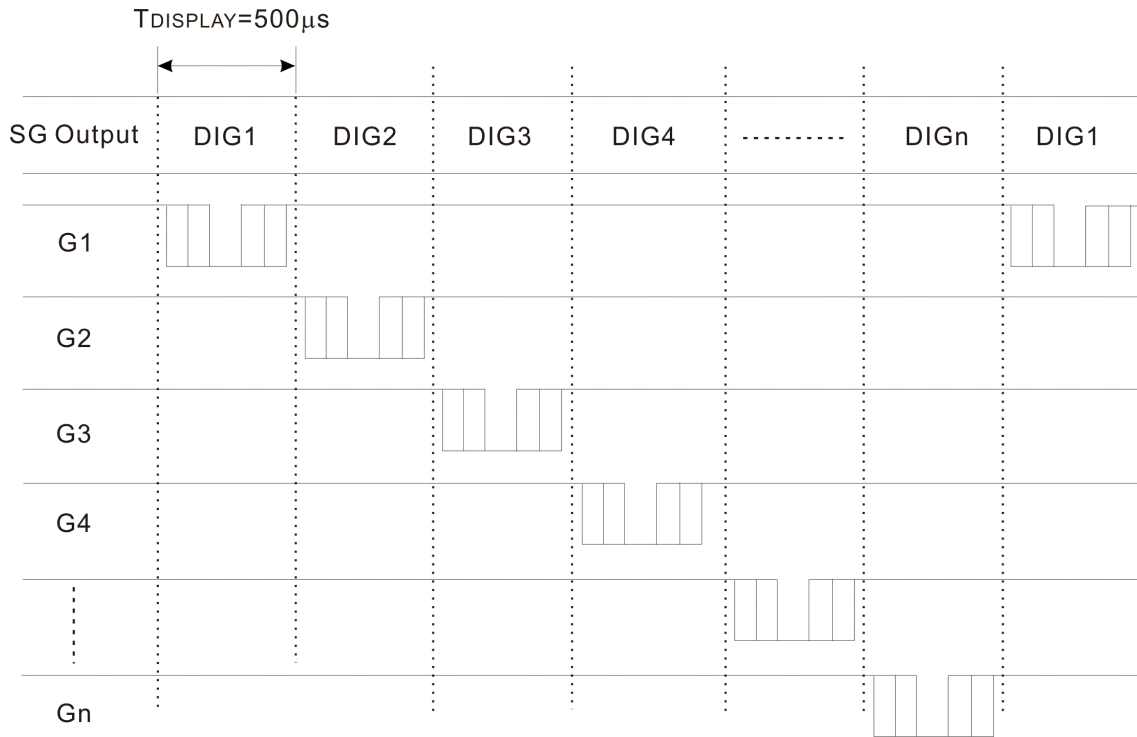

SERIAL COMMUNICATION FORMAT

The following diagram shows the PT6959 serial communication format.

RECEPTION (DATA/COMMAND WRITE)

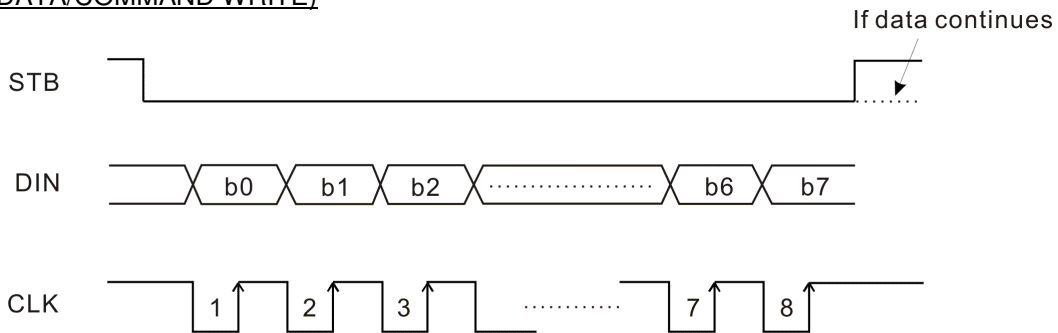

SWITCHING CHARACTERISTIC WAVEFORM

PT6959 Switching Characteristic Waveform s given below.

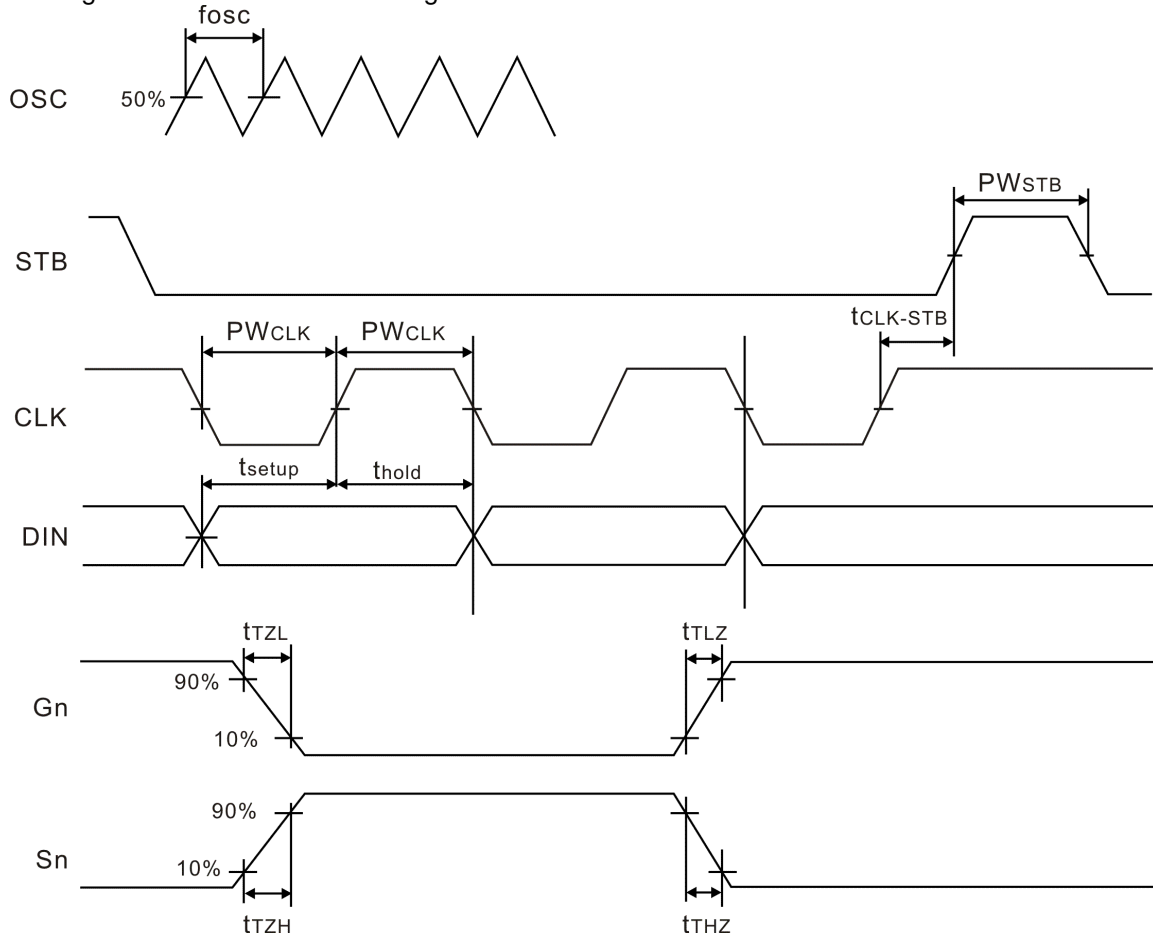

where:

PW_{CLK} (Clock Pulse Width) $\geq 400ns$
 t_{setup} (Data Setup Time) $\geq 100ns$
 $t_{CLK-STB}$ (Clock - Strobe Time) $\geq 1\mu s$
 t_{TZH} (Rise Time) $\leq 1\mu s$
 $t_{TZL} < 1\mu s$

PW_{STB} (Strobe Pulse Width) $\geq 1\mu s$
 t_{hold} (Data Hold Time) $\geq 100ns$
 t_{THZ} (Fall Time) $\leq 10\mu s$
 f_{osc} = Oscillation Frequency
 $t_{TLZ} < 10\mu s$

APPLICATIONS

Display memory is updated by incrementing addresses. Please refer to the following diagram.

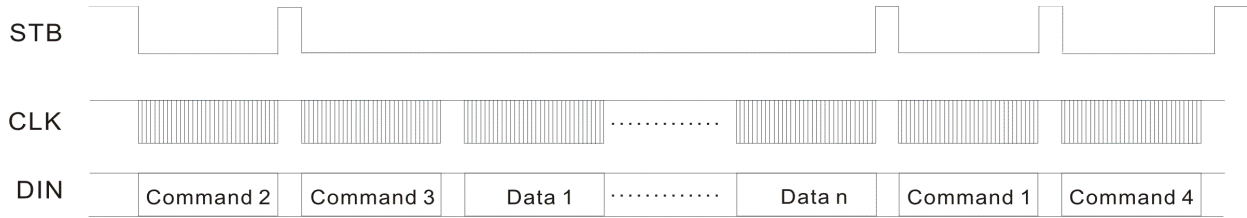

where: Command 1: Display Mode Setting Command
 Command 2: Data Setting Command
 Command 3: Address Setting Command
 Data 1 to n : Transfer Display Data (14 Bytes max.)
 Command 4: Display Control Command

The following diagram shows the waveforms when updating specific addresses.

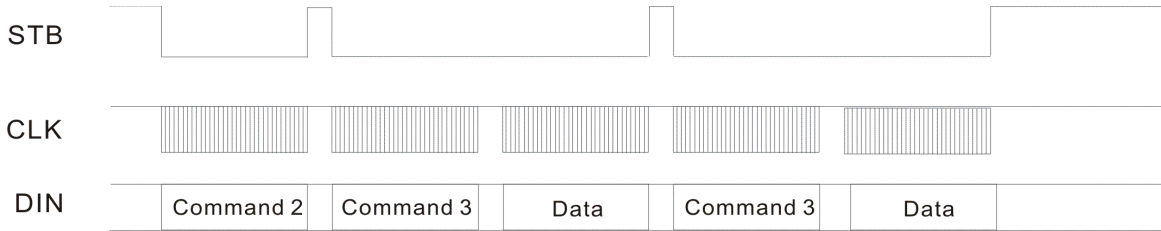

where: Command 2: Data Setting Command
 Command 3: Address Setting Command
 Data: Display Data

RECOMMENDED SOFTWARE PROGRAMMING FLOWCHART

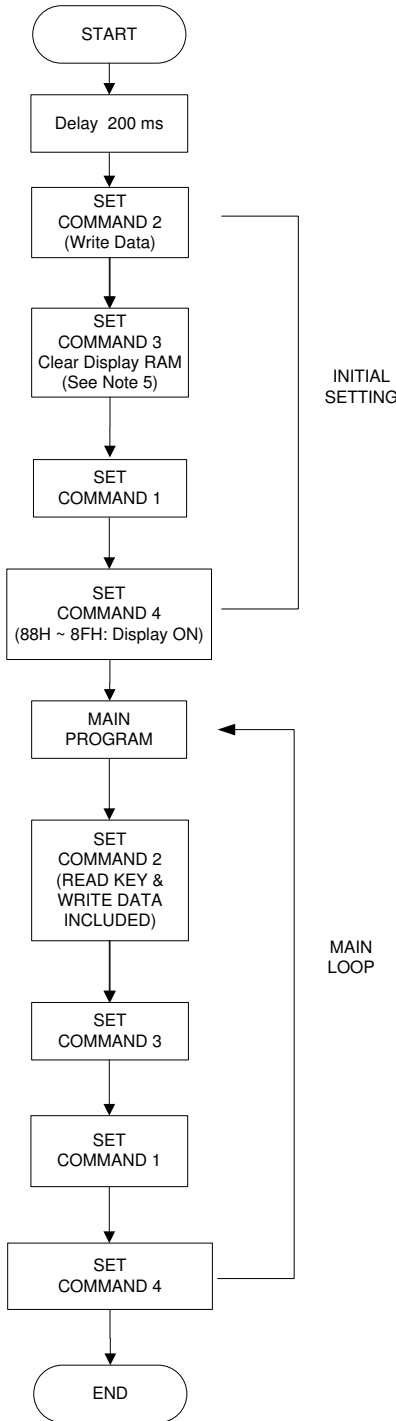

Notes:

1. Command 1: Display Mode Setting Commands
2. Command 2: Data Setting Commands
3. Command 3: Address Setting Commands
4. Command 4: Display Control Commands
5. When IC power is applied for the first time, the contents of the Display RAM are not defined; thus, it is strongly suggested that the contents of the Display RAM must be cleared during the initial setting.

SOP 28 (300MIL) THERMAL PERFORMANCE IN STILL AIR AT $T_J=100^{\circ}\text{C}$

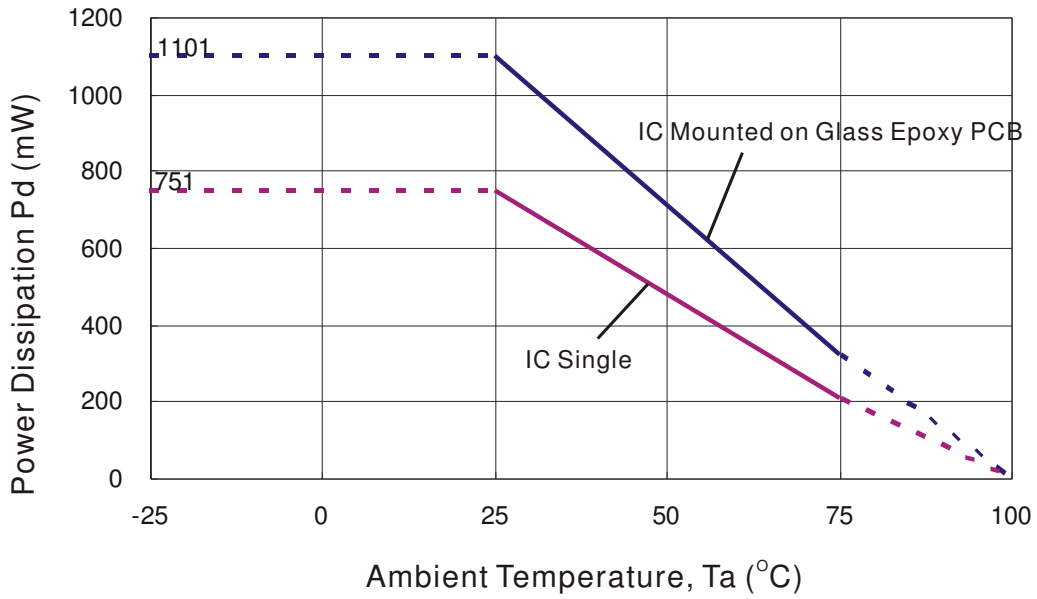

ABSOLUTE MAXIMUM RATINGS

(Unless otherwise stated, Ta=25°C, GND=0V)

Parameter	Symbol	Rating	Units
Supply Voltage	VDD	-0.3 to +7.0	V
Logic Input Voltage	VI	-0.3 to VDD+0.3	V
Driver Output Current/Pin	IOLGR	+250	mA
	IOHSG	-50	mA
Maximum Driver Output Current/Total	ITOTAL	400	mA
Operating Temperature	Topr	-40 ~ +85	°C
Storage Temperature	Tstg	-40 ~ +150	°C

RECOMMENDED OPERATING RANGE

(Unless otherwise stated, Ta=25°C, GND=0V)

Parameter	Symbol	Min.	Typ.	Max.	Unit
Logic Supply Voltage	VDD	4.5	5	5.5	V
Dynamic Current (see note)	IDDdyn	-	-	5	mA
High-Level Input Voltage	VIH	0.8VDD	-	VDD	V
Low-Level Input Voltage	VIL	0	-	0.3VDD	V

Note: Test Condition: Set Display Control Commands = 80H (Display Turn Off State)

ELECTRICAL CHARACTERISTICS

(Unless otherwise stated, VDD=5V, GND=0V, Ta=25°C)

Parameter	Symbol	Test Condition	Min.	Typ.	Max.	Unit
High-Level Output Current	IOHSG(1)	VO=VDD-1V, SG1 to SG11, SG12/GR7 to SG14/GR5	-10	-14	-30	mA
	IOHSG(2)	VO=VDD-2V, SG1 to SG11, SG12/GR7 to SG14/GR5	-20	-25	-50	mA
Low-Level Output Current	IOLGR	VO=0.3V, GR1 to GR4, SG12/GR7 to SG14/GR5	100	140	-	mA
Segment High-Level Output Current Tolerance	ITOLSG	VO=VDD-1V, SG1 to SG11, SG12/GR7 to SG14/GR5	-	-	±5	%
High-Level Input Voltage	VIH	-	0.8VDD	-	-	V
Low-Level Input Voltage	VIL	-	-	-	0.3VDD	V
Oscillation Frequency	fosc	R=51KΩ	350	500	650	KHz

PACKAGE INFORMATION

28 PINS, SOP, 300MIL

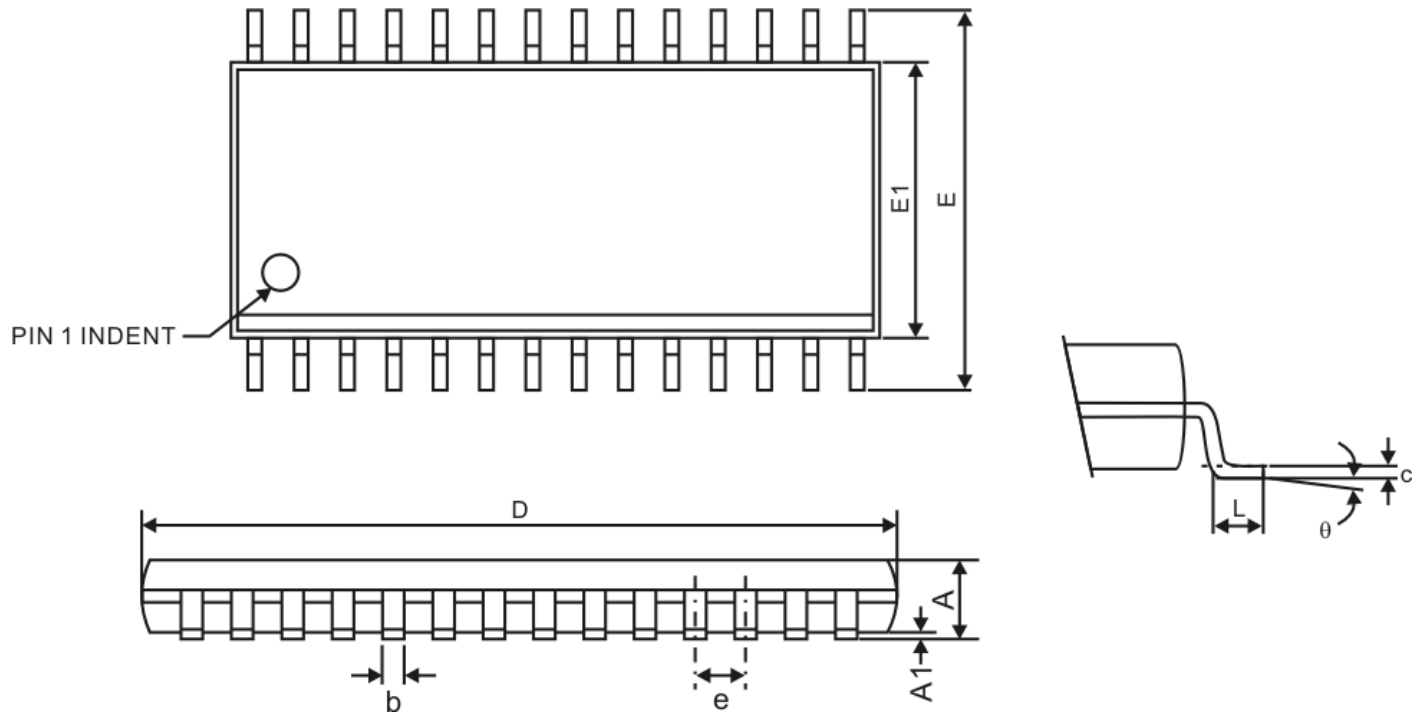

Symbol	Min.	Nom.	Max.
A	2.35	-	2.65
A1	0.10	-	0.30
b	0.33	-	0.51
c	0.23	-	0.32
D	17.7		18.10
E	10.00		10.65
E1	7.40		7.60
e	1.27 BSC		
L	0.40	-	1.27
θ	0°	-	8°

Notes:

1. All dimensions are in millimeter.
2. Refer to JEDEC MS-012AE

IMPORTANT NOTICE

Princeton Technology Corporation (PTC) reserves the right to make corrections, modifications, enhancements, improvements, and other changes to its products and to discontinue any product without notice at any time.

PTC cannot assume responsibility for use of any circuitry other than circuitry entirely embodied in a PTC product. No circuit patent licenses are implied.

Princeton Technology Corp.
2F, 233-1, Baociao Road,
Sindian, Taipei 23145, Taiwan
Tel: 886-2-66296288
Fax: 886-2-29174598
<http://www.princeton.com.tw>