

DESCRIPTION

PT16972 is a 4-Channel constant current LED driver with current-mode switching DC-DC controller. The output current range can be externally programmed for 10mA~100mA per channel. Also, the output voltage can be up to 36V. The PT16972 supports the boost, coupled-inductor boost-buck or SEPIC topologies and operates in an adjustable switching frequency between 200kHz and 2.1MHz.

High PWM dimming ratio 2500:1 can be achieved by internal fast response time 2 μ s with 200Hz PWM dimming frequency.

The PT16972 allows to detect and manage the open and shorted LED faults and to let unused channel floating. Also, the device includes output over-voltage protection, thermal shutdown protection and internal power MOSFET over-current protection. Two fault indication pins are provided to separate the failure mode.

APPLICATIONS

- Automotive Navigation LCD Panel Backlight
- Desktop and Notebook LCD Panel Backlight
- PDAs Panel Backlight

FEATURES

- 6V~36V Input Voltage
- Output Voltage Up to 36V
- Output Current Range 10mA~100mA/CH
- $\pm 1\%$ LED Current Matching at 20mA or Higher
- Programmable Frequency 200KHz~2.1MHz
- 2 μ s Minimum PWM Dimming on Time
- Support Boost, Coupled-Inductor Boost-Buck or SEPIC Topologies
- Selectable Output Channels
- Low Standby Current
- Adjustable Internal MOSFET Current Limitation and Soft-Start
- LED Open / Short Protection
- Output Over-Voltage Protection
- Thermal Shutdown Protection at 150 $^{\circ}$ C
- Two Fault Indication Pins
- TSSOP24 (173mil) with Exposed PAD Package

BLOCK DIAGRAM

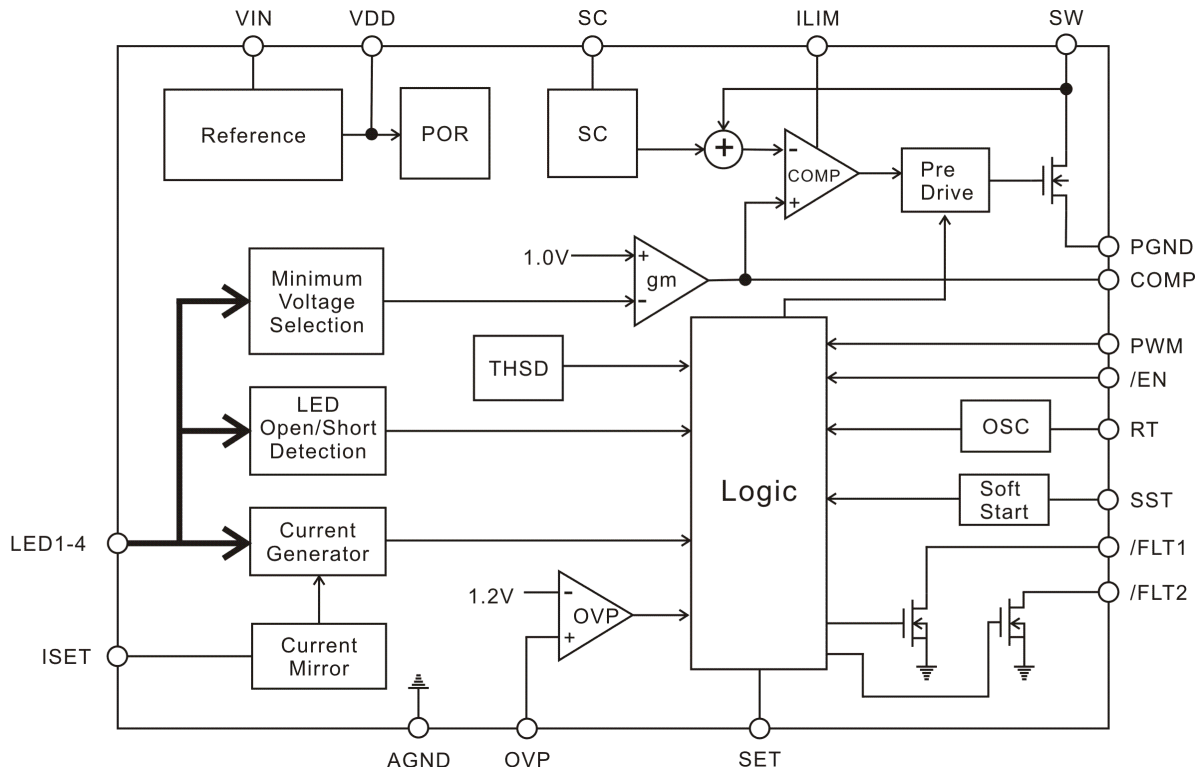

TYPICAL APPLICATION

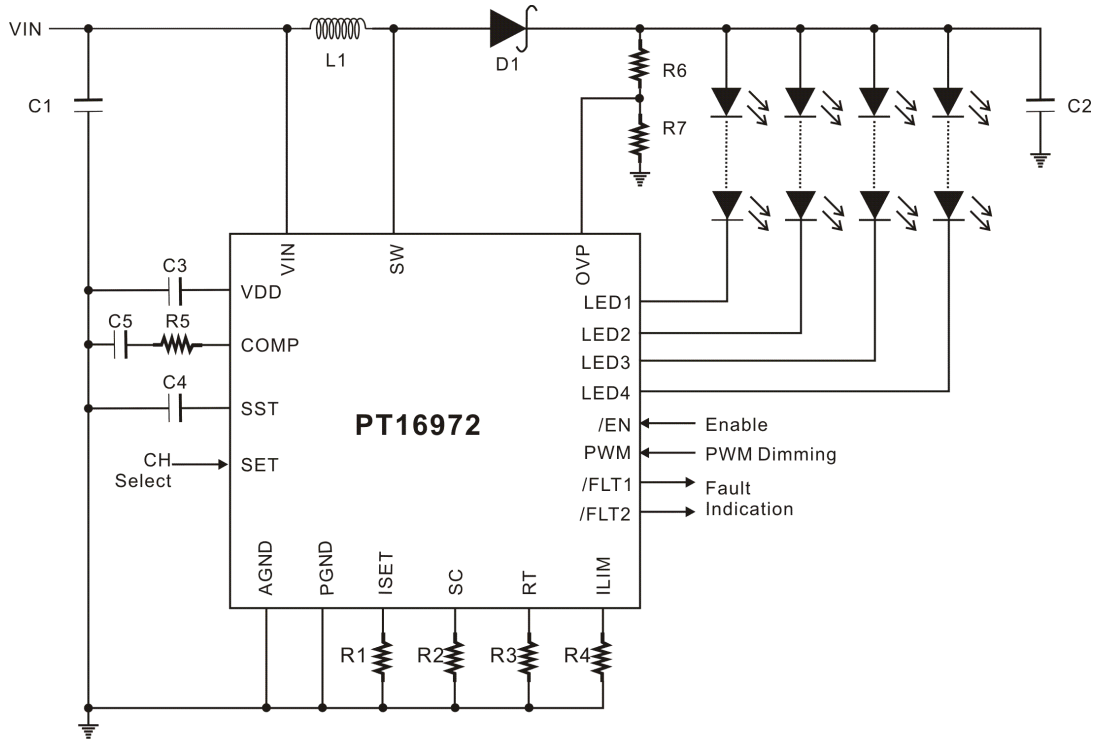

Boost Configuration

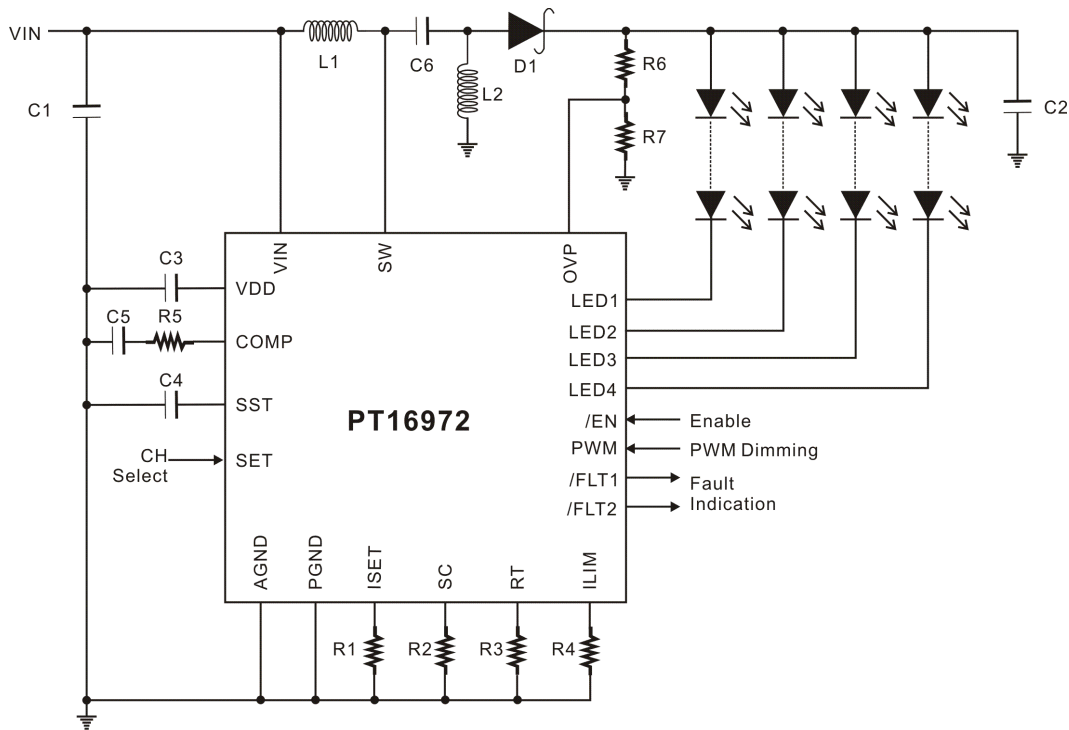

SEPIC Configuration

ORDER INFORMATION

Valid Part Number	Package Type	Top Code
PT16972	HTSSOP24	PT16972-HT

PIN CONFIGURATION

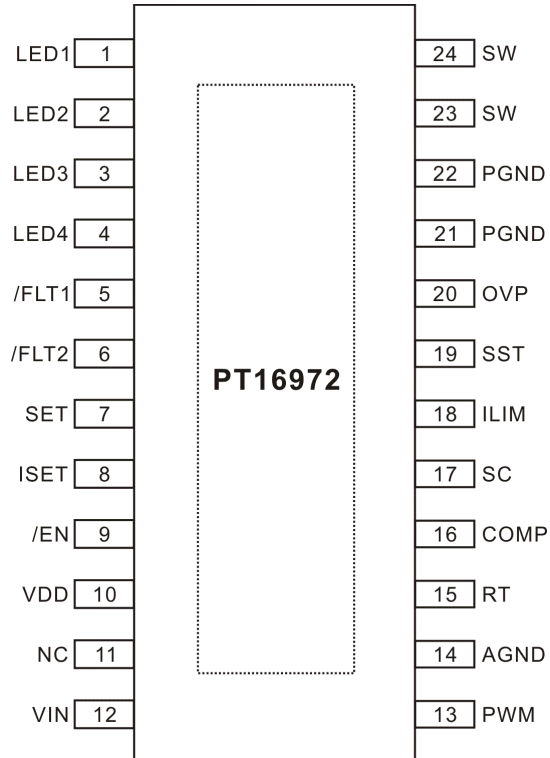



PIN DESCRIPTION

Pin Name	Description	Pin No.
LED1	LED String Driver Output 1.	1
LED2	LED String Driver Output 2.	2
LED3	LED String Driver Output 3.	3
LED4	LED String Driver Output 4.	4
/FLT1	Fault Signal Open Drain Output. /FLT1 will be low when LED open or shorted is detected.	5
/FLT2	Fault Signal Open Drain Output. /FLT2 will be low when thermal shutdown or output over-voltage is detected.	6
SET	Channel Selection. Pin logic level will set the output channels: SET=0 or floating, 4 channels are used; SET=1, LED4 is not used. An internal 100kΩ pull-low resistor is used.	7
ISET	LED Current Setting. A resistor to AGND to program the output current per channel.	8
/EN	Enable Control. /EN=0 or floating, the device is turn on. /EN=1, the device is turned off. An internal 100KΩ pull-low resistor is used.	9
VDD	Internal 5V Regulator Output. Bypass to AGND with a 10μF ceramic capacitor.	10
NC	Non-Connection.	11
VIN	Input Supply Voltage.	12
PWM	External PWM Dimming Input. PWM=0 or floating, the switching and the current generators are turned off. PWM=1, the switching and the current generators operate normally. An internal 100KΩ pull-low resistor is used.	13
AGND	Analog Ground.	14
RT	Switching Frequency Setting. A resistor to AGND which programs the switching frequency between 200KHz and 2.1MHz.	15
COMP	Error Amplifier Output pin. Tie the external compensation network.	16
SC	Slope Compensation Setting. A resistor between this pin and AGND is needed. It can avoid sub-harmonic instability.	17
ILIM	Internal Switch Current Limit Setting. A resistor to AGND to program the current limit level of power MOSFET.	18
SST	Soft-Start. Connect a capacitor to AGND to set the soft-start time.	19
OVP	Over Voltage Protection. When $V_{OVP} > 1.2V$, the over-voltage protection occurs.	20
PGND	Power Ground. Source of internal power MOSFET.	21
PGND	Power Ground. Source of internal power MOSFET.	22
SW	Switching pin. Drain of internal power MOSFET.	23
SW	Switching pin. Drain of internal power MOSFET.	24