

DESCRIPTION

The PT6575C is 1/3 duty and 1/4 duty general-purpose LCD driver that can be used for frequency display in electronic tuners under the control of a microcontroller. The PT6575C can drive an LCD with up to 420 segments directly. The PT6575C can also control up to 8 general-purpose output ports.

APPLICATION

- Electronic equipment with LCD Display

FEATURES

- Switching between 1/3 duty and 1/4 duty drive techniques under serial data control.
- Switching between 1/2 bias and 1/3 bias drive techniques under serial data control.
- Up to 318 segments for 1/3 duty drive and 420 segments for 1/4 duty drive can be displayed.
- Serial interface for clock, Data Input, Data Output, Strobe pins.
- Serial data control of the power-saving mode based backup function and all the segments forced off function.
- Serial data control of switching between the segment output port and the general-purpose output port functions.
- Serial data control of frame frequency for common and segment output waveforms.
- High generality, since display data is displayed directly without decoder intervention.
- Built-in display contrast adjustment circuit
- Independent VLCD for the LCD driver block
- The /INH pin can force the display to the off state.
- RC oscillator circuit

BLOCK DIAGRAM

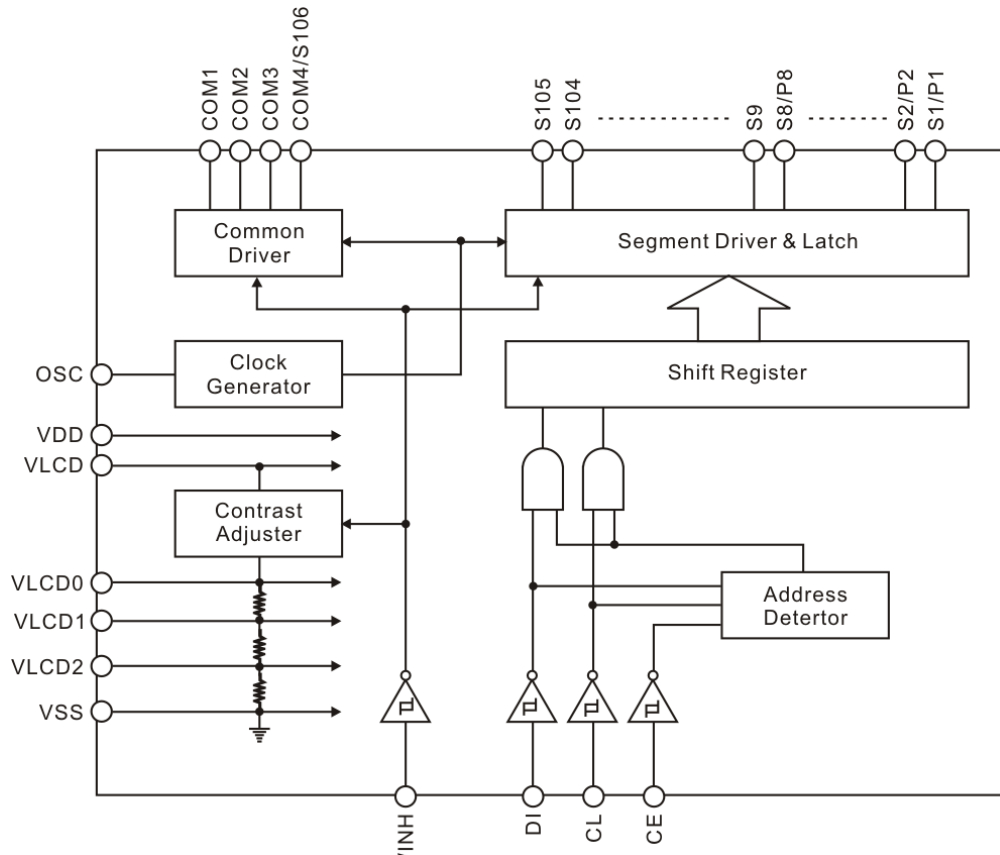

APPLICATION CIRCUIT

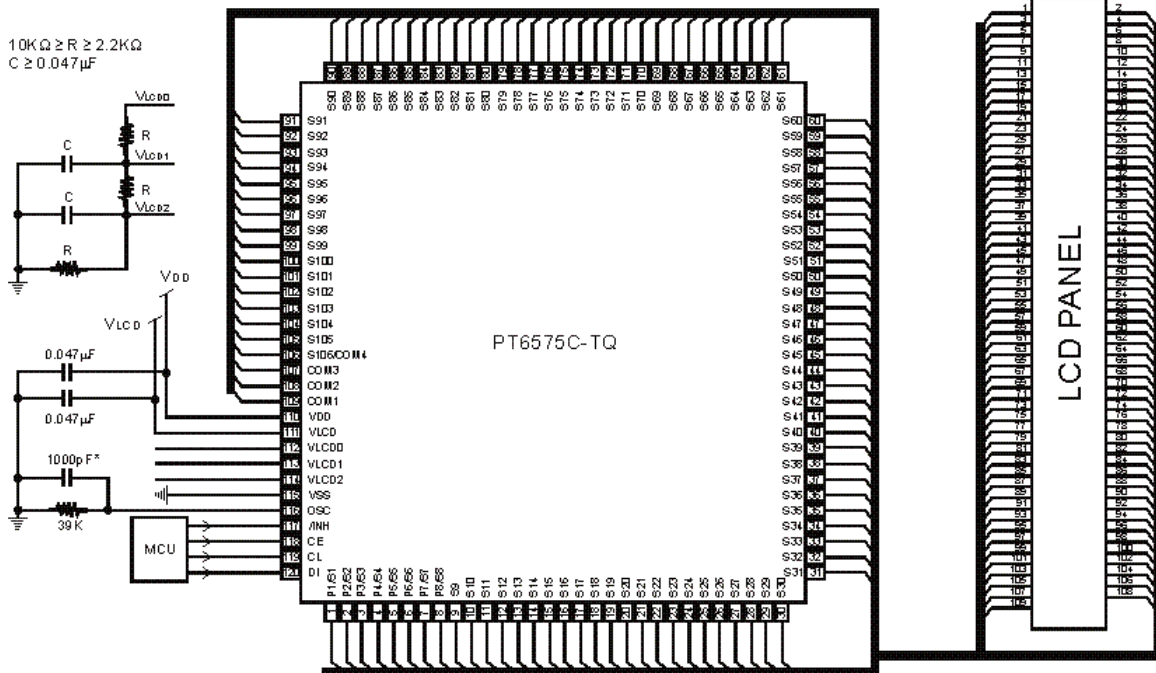

Note:
 *=When a capacitor except the recommended external capacitance (Cosc=1000pF) is connected the OSC pin, we recommend that applications connect the OSC pin with a capacitor in the range 220 to 2200pF.



ORDER INFORMATION

Valid Part Number	Package Type	Top Code
PT6575C-TQ	120 Pins, TQFP	PT6575C-TQ

PIN CONFIGURATION

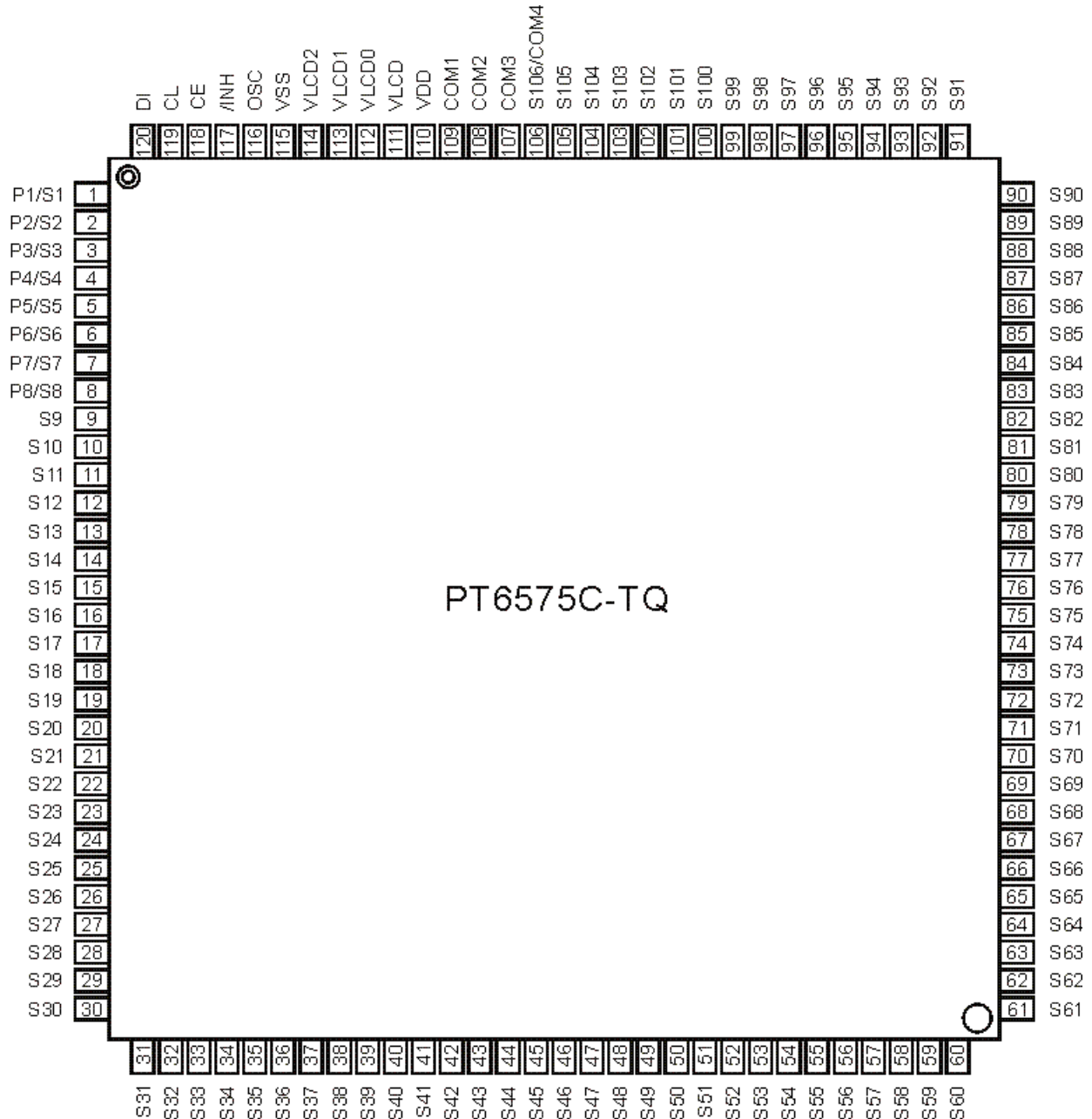

PIN DESCRIPTION

Pin Name	I/O	Active	Handling when unused	Function	Pin No.
S1/P1 to S8/P8 S9 to S105	O	-	Open	Segment outputs for displaying the display data transferred by serial data input. The pins S1/P1 to S8/P8 can be used as general-purpose output ports when so set up by the control data.	1 to 8 9 to 105
COM1 to COM3 COM4/S106	O	-	Open	Common driver outputs. The frame frequency is f_0 Hz. The COM4/S106 pin can be used as a segment output in 1/3 duty.	109 to 107 106
OSC	I/O	-	VDD	Oscillator connection. An oscillator circuit is formed by connecting an external resistor and capacitor to this pin.	116
CE CL DI	I	H	GND	Serial data transfer inputs. These pins are connected to the control microprocessor. CE: Chip enable CL: Synchronization clock DI: Transfer data	118
	I				119
	I	-			120
/INH	I	L	GND	Display off control input <ul style="list-style-type: none"> /INH=low (V_{SS})...off S1/P1 to S8/P8=low (V_{SS}) (These pins are forcibly set to the segment output port function and fixed at the V_{SS} level) S9 to S105=low (V_{SS}) COM1 to COM3=low (V_{SS}) COM4/S106=low(V_{SS}) /INH=high (V_{DD})...on Note that serial data transfers can be performed when the display is forced off by this pin.	117
VLCD0	O	-	Open	LCD Drive 3/3 bias voltage (high level) supply. This level can be modified using the display contrast adjustment circuit. However, note that V_{LCD0} must be greater than or equal to 2.7V. Also, since this IC provides the built-in display contrast adjustment circuit, applications must not attempt to provide this level from external circuits.	112
VLCD1	I	-	Open	LCD drive 2/3 bias voltage (middle level) supply. It is possible to supply the 2/3 V_{LCD0} voltage to this pin externally. This pin must be shorted to V_{LCD2} if 1/2 bias is used.	113
VLCD2	I	-	Open	LCD drive 1/3 bias voltage (middle level) supply. It is possible to supply the 1/3 V_{LCD0} voltage to this pin externally. This pin must be shorted to V_{LCD1} if 1/2 bias is used.	114
VDD	-	-	-	Logic block power supply. Provide a voltage in the range 2.7 to 6.0V.	110
VLCD	-	-	-	LCD driver block power supply. When V_{LCD0} is between $0.7V_{LCD}$ and $0.95V_{LCD}$, supply a voltage in the range 4.0 to 6.0V. When V_{LCD0} and V_{LCD} will be equal, supply a voltage in the range 2.7 to 6.0V.	111
VSS	-	-	-	Ground pin. Connect to ground.	115

IMPORTANT NOTICE

Princeton Technology Corporation (PTC) reserves the right to make corrections, modifications, enhancements, improvements, and other changes to its products and to discontinue any product without notice at any time.

PTC cannot assume responsibility for use of any circuitry other than circuitry entirely embodied in a PTC product. No circuit patent licenses are implied.

Princeton Technology Corp.
2F, 233-1, Baociao Road,
Sindian, Taipei 23145, Taiwan
Tel: 886-2-66296288
Fax: 886-2-29174598
<http://www.princeton.com.tw>