

DESCRIPTION

The PT6530 are 1/3 duty and 1/4 duty LCD display drivers that can directly drive up to 300 segments and can control up to eight general-purpose output ports. These products also incorporate a key scan circuit that accepts input from up to 30 keys to reduce printed circuit board wiring.

APPLICATION

- Electronic Equipment with LCD Display

FEATURES

- Key input function for up to 30 keys (A key scan is performed only when a key is pressed.)
- 1/3 duty and 1/4 duty drive schemes can be controlled from serial data.
- 1/2 bias and 1/3 bias drive schemes can be controlled from serial data.
- Capable of driving up to 228 segments using 1/3 duty and up to 300 segments using 1/4 duty.
- Sleep mode and all segments off functions that are controlled from serial data.
- Segment output port/general-purpose output port function switching that is controlled from serial data.
- Serial Interface for clock, Data Input, Data Output, Strobe pins.
- Direct display of display data without the use of a decoder provides high generality.
- Independent VLCD for the LCD driver block (VLCD can be set to in the range VDD – 0.5 to 6.0V)
- Provision of an on-chip voltage-detection type reset circuit prevents incorrect displays.
- RES pin provided for forcibly initializing the IC internal circuits.
- RC oscillator circuit.

BLOCK DIAGRAM

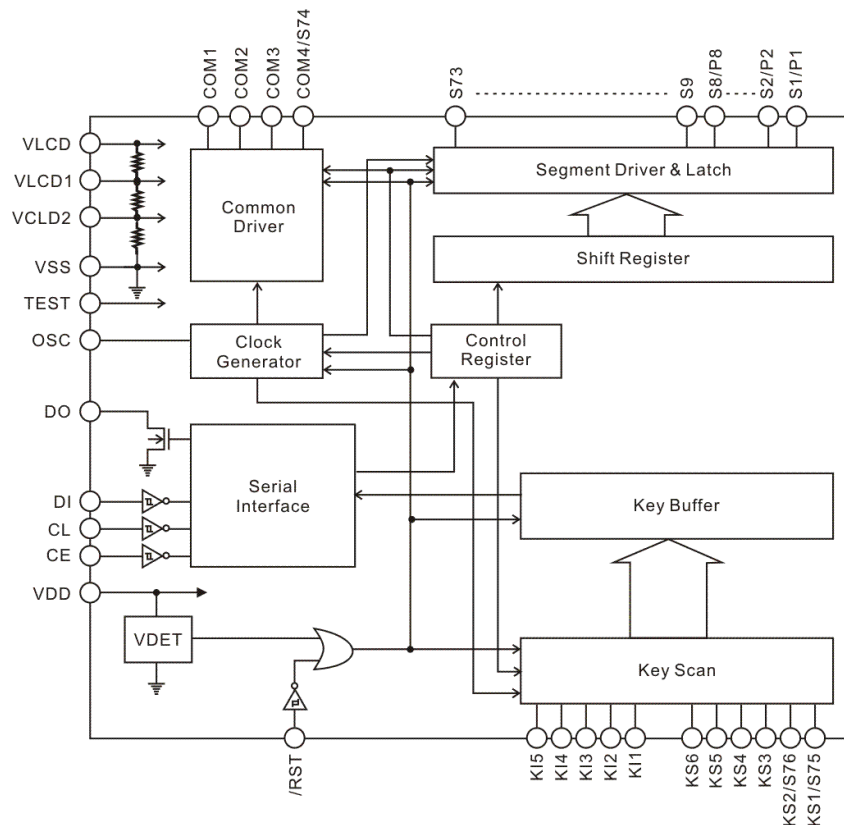

CONTENTS

1. APPLICATION CIRCUITS.....	3
1.1 1/3 DUTY 1/2 BIAS (FOR NORMAL PANEL USE).....	3
1.2 1/3 DUTY 1/2 BIAS (FOR LARGE PANEL USE).....	4
1.3 1/3 DUTY 1/3 BIAS (FOR NORMAL PANEL USE).....	5
1.4 1/3 DUTY 1/3 BIAS (FOR LARGE PANEL USE).....	6
1.5 1/4 DUTY 1/2 BIAS (FOR NORMAL PANEL USE).....	7
1.6 1/4 DUTY 1/2 BIAS (FOR LARGE PANEL USE).....	8
1.7 1/4 DUTY 1/3 BIAS (FOR NORMAL PANEL USE).....	9
1.8 1/4 DUTY 1/3 BIAS (FOR LARGE PANEL USE).....	10
2. ORDER INFORMATION.....	11
3. PIN CONFIGURATION.....	11
4. PIN DESCRIPTION.....	12
5. INPUT/OUTPUT CONFIGURATIONS.....	13
6. FUNCTION DESCRIPTION.....	14
6.1 SERIAL DATA INPUT.....	14
6.2 CONTROL DATA.....	18
6.3 DISPLAY DATA AND OUTPUT PI CORRESPONDENCE.....	20
6.4 SERIAL DATA OUTPUT.....	23
6.5 OUTPUT DATA.....	24
6.6 SLEEP MODE.....	24
6.7 KEY SCAN OPERATION FUNCTIONS.....	25
6.8 MULTIPLE KEY PRESSES.....	26
6.9 1/3 DUTY, 1/2 BIAS DRIVE TECHNIQUE.....	27
6.10 1/3 DUTY, 1/3 BIAS DRIVE TECHNIQUE.....	28
6.11 1/4 DUTY, 1/2 BIAS DRIVE TECHNIQUE.....	29
6.12 1/4 DUTY, 1/3 BIAS DRIVE TECHNIQUE.....	30
6.13 VOLTAGE DETECTION TYPE RESET CIRCUIT (VDET).....	31
6.14 POWER SUPPLY SEQUENCE.....	31
6.15 SYSTEM RESET.....	31
6.16 NOTE ON TRANSFERRING DISPLAY DATA FROM THE CONTROLLER.....	34
6.17 NOTE ON THE CONTROLLER KEY DATA READ TECHNIQUES.....	35
7. ABSOLUTE MAXIMUM RATINGS.....	38
8. ALLOWABLE OPERATING RANGES.....	38
9. ELECTRICAL CHARACTERISTICS.....	39
10. PACKAGE INFORMATION.....	41
IMPORTANT NOTICE.....	42
REVISION HISTORY.....	43

1. APPLICATION CIRCUITS

1.1 1/3 DUTY 1/2 BIAS (FOR NORMAL PANEL USE)

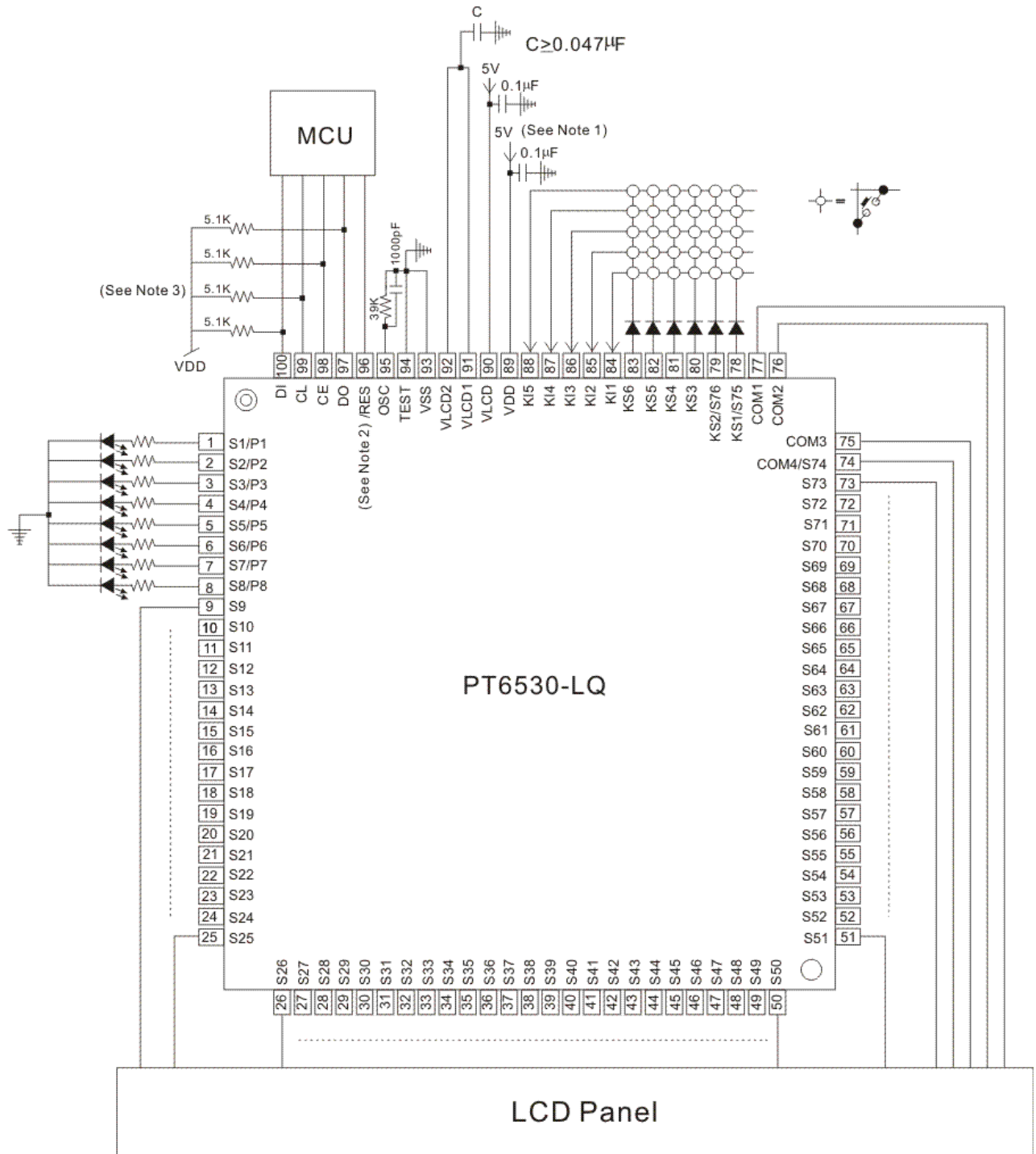

Notes:

1. A capacitor can be connected to the power supply line to make the power supply voltage VDD rise time (when power is applied) and the power supply voltage VDD fall time power drops) are at least 1ms when PT6530 is reset via VDET.
2. If the /RES pin is not used to initiate the System Reset Function, it must be connected VDD.
3. The DO pin is an open-drain output and therefore needs a pull-up resistor. This resistor is between 1K and 10KΩ. The value of this resistor must be in accordance with that capacitance of the external wiring so that the signal waveforms are in proper form.

1.2 1/3 DUTY 1/2 BIAS (FOR LARGE PANEL USE)

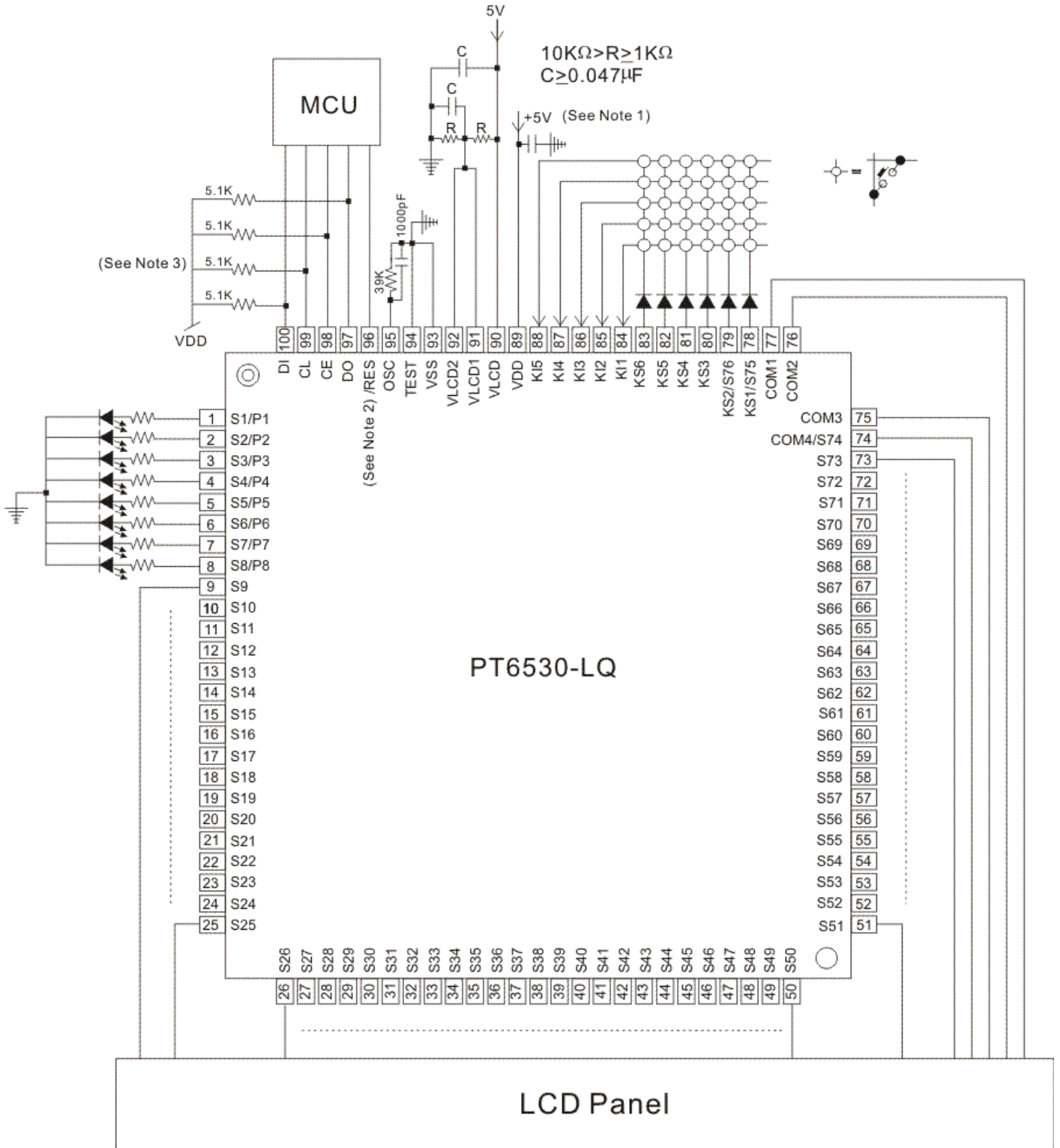

Notes:

1. A capacitor can be connected to the power supply line to make the power supply voltage VDD rise time (when power is applied) and the power supply voltage VDD fall time power drops) are at least 1ms when PT6530 is reset via VDET.
2. If the /RES pin is not used to initiate the System Reset Function, it must be connected VDD.
3. The DO pin is an open-drain output and therefore needs a pull-up resistor. This resistor is between 1K and 10KΩ. The value of this resistor must be in accordance with that capacitance of the external wiring so that the signal waveforms are in proper form.

1.3 1/3 DUTY 1/3 BIAS (FOR NORMAL PANEL USE)

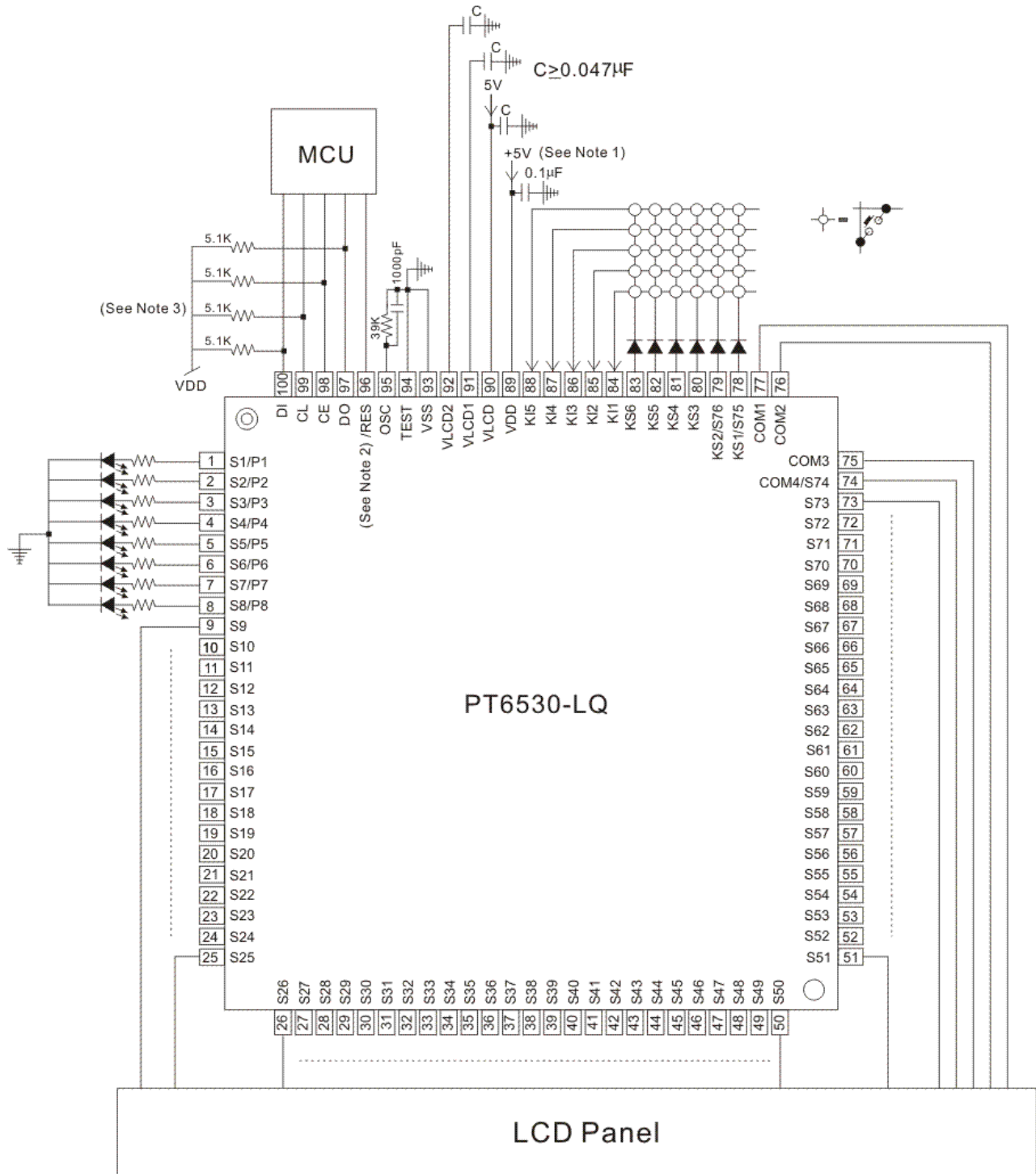

Notes:

1. A capacitor can be connected to the power supply line to make the power supply voltage VDD rise time (when power is applied) and the power supply voltage VDD fall time power drops) are at least 1ms when PT6530 is reset via VDET.
2. If the /RES pin is not used to initiate the System Reset Function, it must be connected VDD.
3. The DO pin is an open-drain output and therefore needs a pull-up resistor. This resistor is between 1K and 10KΩ. The value of this resistor must be in accordance with that capacitance of the external wiring so that the signal waveforms are in proper form.

1.4 1/3 DUTY 1/3 BIAS (FOR LARGE PANEL USE)

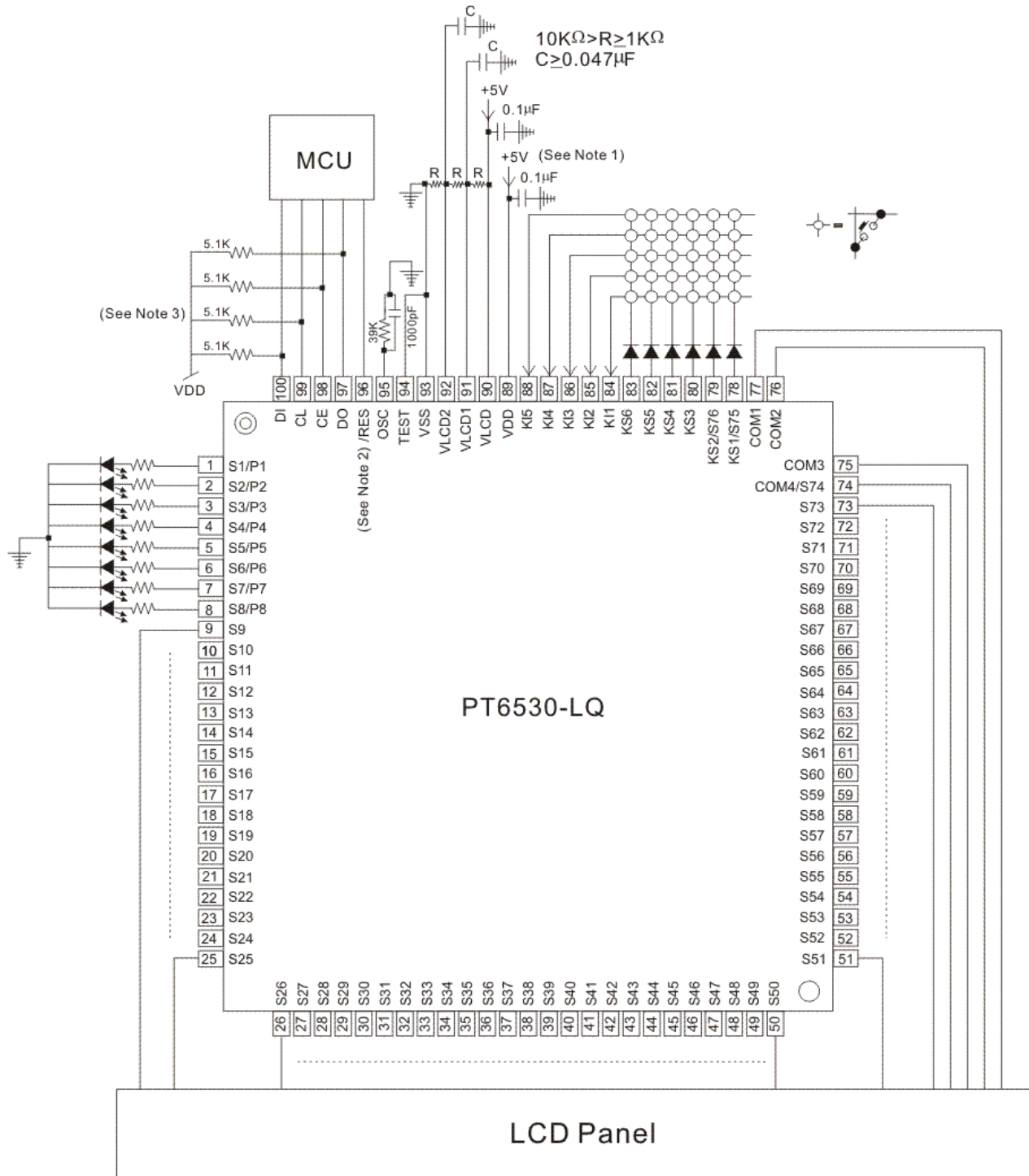

Notes:

1. A capacitor can be connected to the power supply line to make the power supply voltage VDD rise time (when power is applied) and the power supply voltage VDD fall time power drops) are at least 1ms when PT6530 is reset via VDET.
2. If the /RES pin is not used to initiate the System Reset Function, it must be connected VDD.
3. The DO pin is an open-drain output and therefore needs a pull-up resistor. This resistor is between 1K and 10KΩ. The value of this resistor must be in accordance with that capacitance of the external wiring so that the signal waveforms are in proper form.

1.5 1/4 DUTY 1/2 BIAS (FOR NORMAL PANEL USE)

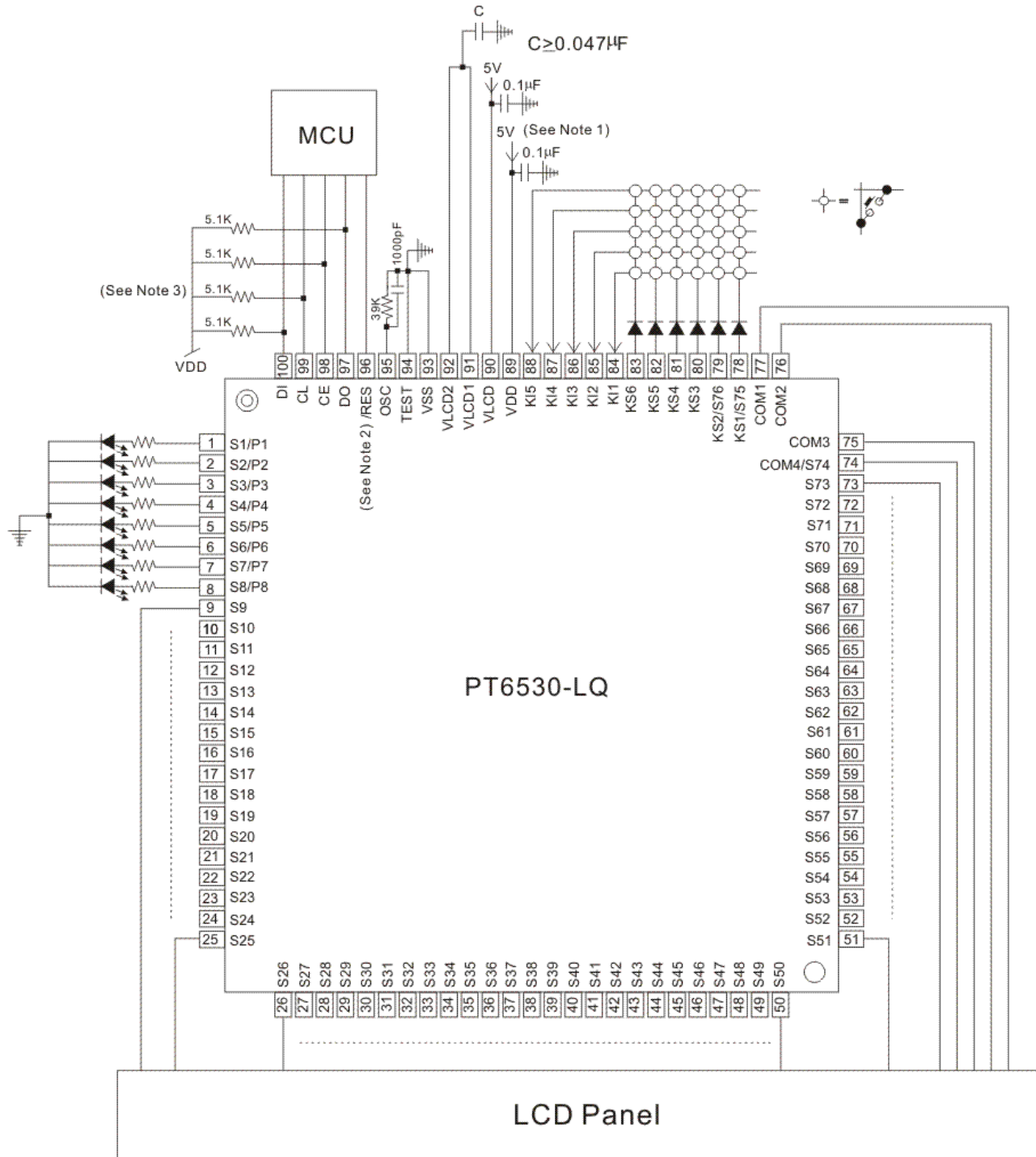

Notes:

1. A capacitor can be connected to the power supply line to make the power supply voltage VDD rise time (when power is applied) and the power supply voltage VDD fall time power drops) are at least 1ms when PT6530 is reset via VDET.
2. If the /RES pin is not used to initiate the System Reset Function, it must be connected VDD.
3. The DO pin is an open-drain output and therefore needs a pull-up resistor. This resistor is between 1K and 10KΩ. The value of this resistor must be in accordance with that capacitance of the external wiring so that the signal waveforms are in proper form.

1.6 1/4 DUTY 1/2 BIAS (FOR LARGE PANEL USE)

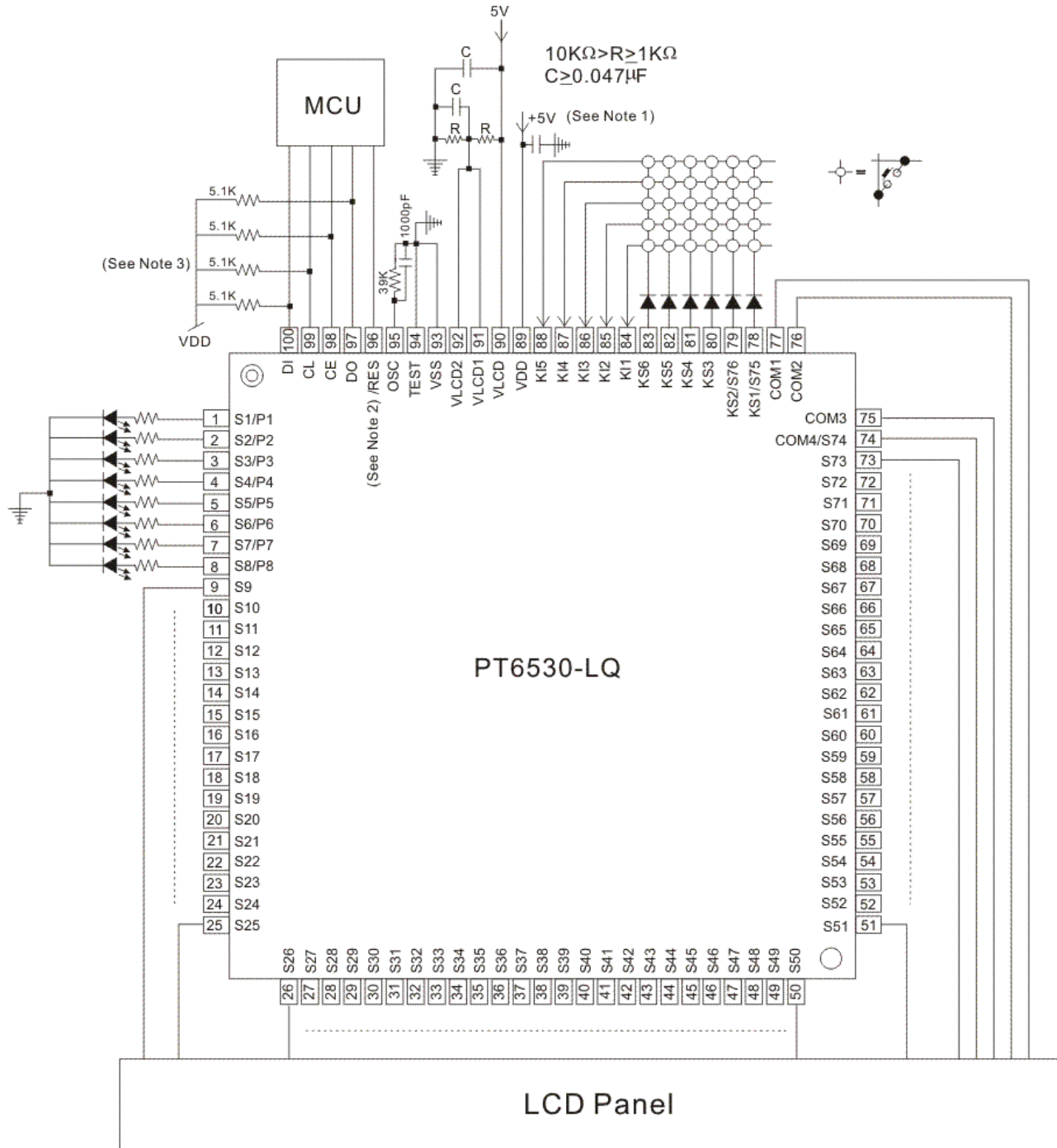

Notes:

1. A capacitor can be connected to the power supply line to make the power supply voltage VDD rise time (when power is applied) and the power supply voltage VDD fall time power drops) are at least 1ms when PT6530 is reset via VDET.
2. If the /RES pin is not used to initiate the System Reset Function, it must be connected VDD.
3. The DO pin is an open-drain output and therefore needs a pull-up resistor. This resistor is between 1K and 10KΩ. The value of this resistor must be in accordance with that capacitance of the external wiring so that the signal waveforms are in proper form.

1.8 1/4 DUTY 1/3 BIAS (FOR LARGE PANEL USE)

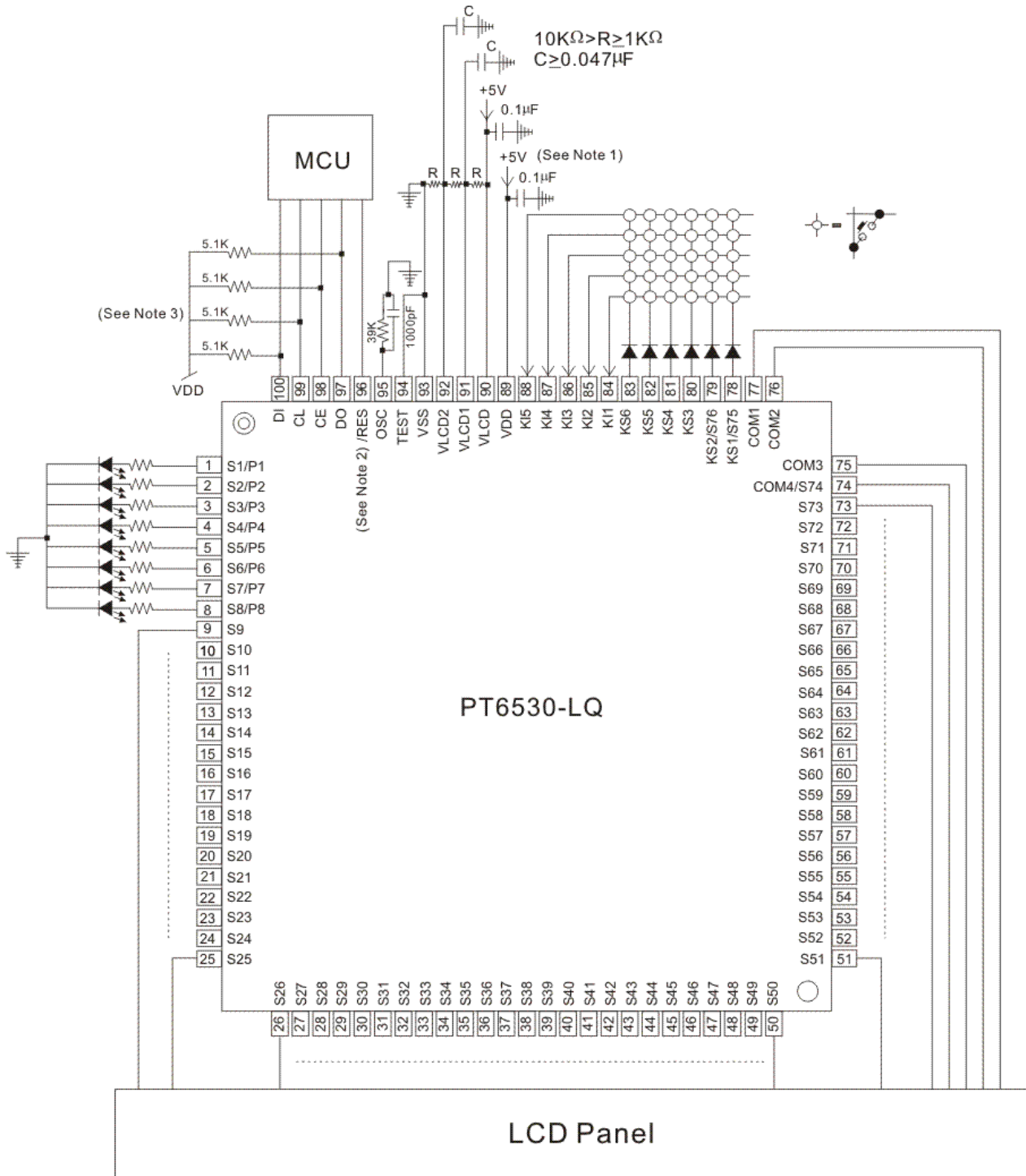

Notes:

1. A capacitor can be connected to the power supply line to make the power supply voltage VDD rise time (when power is applied) and the power supply voltage VDD fall time power drops) are at least 1ms when PT6530 is reset via VDET.
2. If the /RES pin is not used to initiate the System Reset Function, it must be connected VDD.
3. The DO pin is an open-drain output and therefore needs a pull-up resistor. This resistor is between 1K and 10KΩ. The value of this resistor must be in accordance with that capacitance of the external wiring so that the signal waveforms are in proper form.



2. ORDER INFORMATION

Valid Part Number	Package Type	Top Code
PT6530	100 Pins, LQFP	PT6530-LQ

3 PIN CONFIGURATION

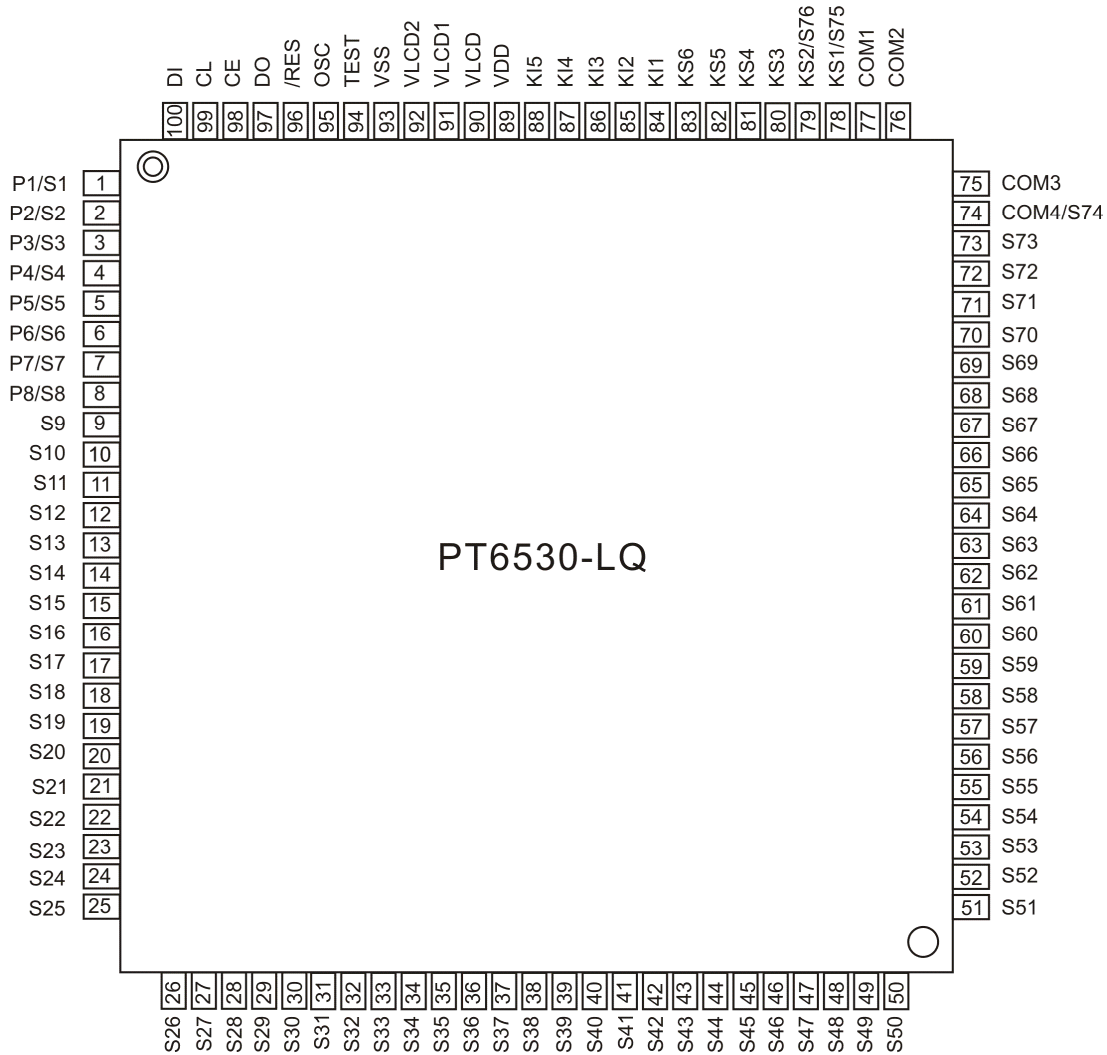

4. PIN DESCRIPTION

Pin Name	I/O	Active	Handling when unused	Description	Pin No.
S1/P1 ~ S8/P8 S9 ~ S73	O	-	OPEN	Segment outputs for displaying the display data transferred by serial data input. The S1/P1 to S8/P8 pins can be used as general-purpose output ports under serial data control.	1 ~ 8 9 ~ 73
COM1 COM2 COM3 COM4/S74	O	-	OPEN	Common driver outputs The frame frequency f_o is given by: $f_o = (f_{osc}/384)$ Hz. The COM4/S74 pin can be used as a segment output in 1/3 duty.	77 76 75 74
KS1/S75 KS2/S76 KS3 ~ KS6	O	-	OPEN	Key scan outputs Although normal key scan timing lines require diodes to be inserted in the timing lines to prevent shorts, since these outputs are unbalanced CMOS transistor outputs, these outputs will not be damaged by shorting when these outputs are used to form a key matrix. The KS1/S75 and KS2/S76 pins can be used as segment outputs when so specified by the control data.	78 79 80 ~ 83
KI1 ~ KI5	I	H	GND	Key scan inputs These pins have built-in pull-down resistors.	84 ~ 88
OSC	I/O	-	VDD	Oscillator connection An oscillator circuit is formed by connecting an external resistor and capacitor at this pin.	95
CE	I	H	GND	Serial data interface connections to the controller. Note that DO, being an open-drain output, requires a pull-up resistor. CE :Chip enable CL :Synchronization clock DI :Transfer data DO :Output data	98
CL	I				99
DI	I	-	OPEN		100
DO	O	-			97
/RES	I	L	VDD	Reset signal input /RES = low.....Display off Key scan disabled All key data is reset to low /RES = high.....Display on Key scan enabled However, serial data can be transferred when /RES is low.	96
TEST	I	-	-	This pin must be connected to ground.	94
VLCD1	I	-	OPEN	Used for applying the LCD drive 2/3 bias voltage externally. Must be connected to VLCD2 when a 1/2 bias drive scheme is used.	91
VLCD2	I	-	OPEN	Used for applying the LCD drive 1/3 bias voltage externally. Must be connected to VLCD1 when a 1/2 bias drive scheme is used.	92
VDD	-	-	-	Logic block power supply connection. Provide a voltage of between 3.0 and 6.0V.	89
VLCD	-	-	-	LCD driver block power supply connection. Provide a voltage of between VDD -0.5 and 6.0V.	90
VSS	-	-	-	Power supply connection. Connect to ground.	93

5. INPUT/OUTPUT CONFIGURATIONS

The schematic diagrams of the input and output circuits of the logic section are shown below:

INPUT PIN: CL, CE, DI

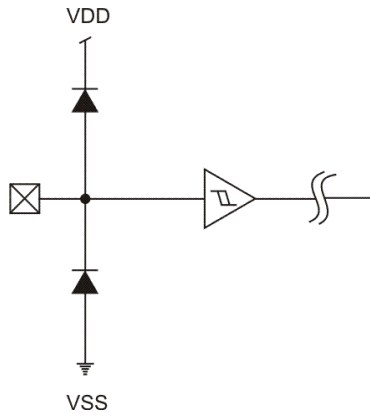

OUTPUT PIN: DO

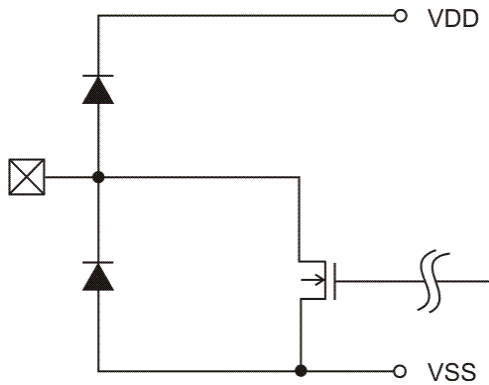

OUTPUT PIN: S1/P1 TO S8/P8, S9 TO S73, S75/KS1, S76/KS2

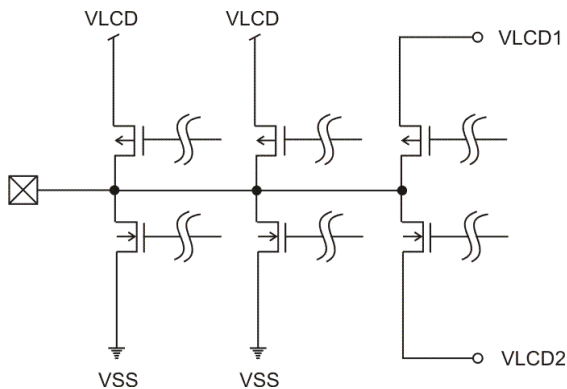

INPUT PIN: K11 TO K15

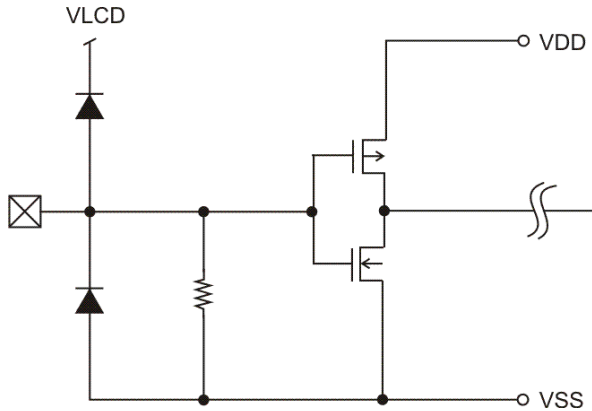

OUTPUT PIN: KS3 TO KS6

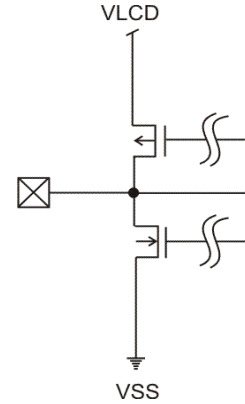

OUTPUT PIN: COM1 TO COM3, COM4/S74

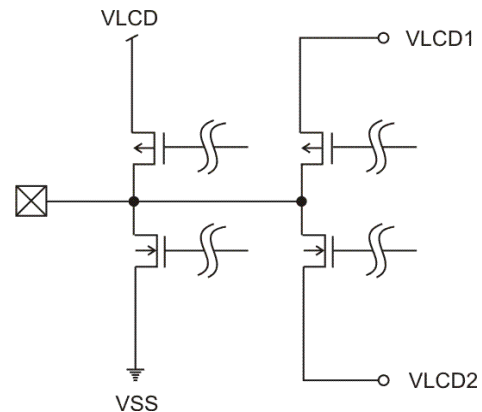

6. FUNCTION DESCRIPTION

6.1 SERIAL DATA INPUT

6.1.1 1/3 DUTY

WHEN CL IS STOPPED AT THE LOW LEVEL

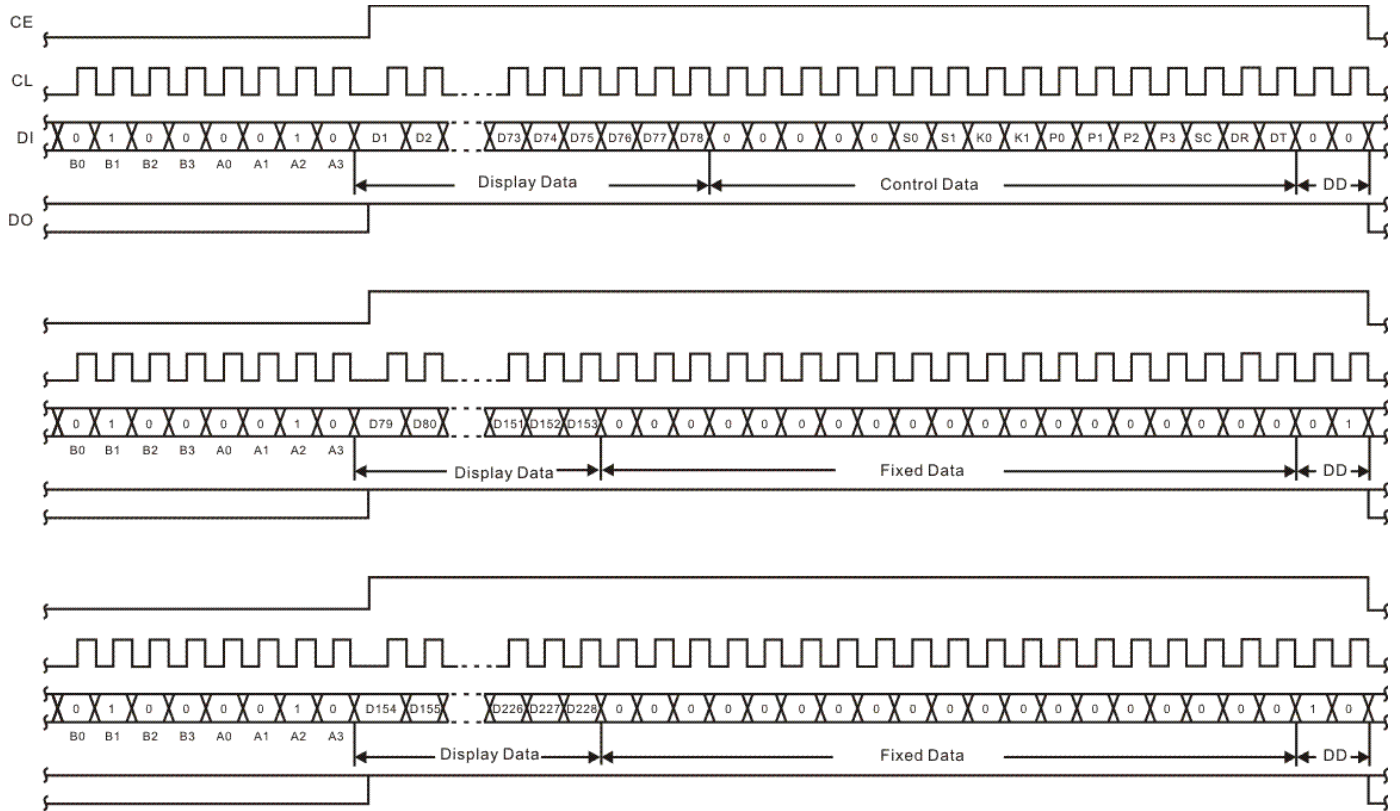

Notes:

1. B0 to B3, A0 to A3 = Serial Interface address
2. DD=Direction Date



WHEN CL IS STOPPED AT THE HIGH LEVEL

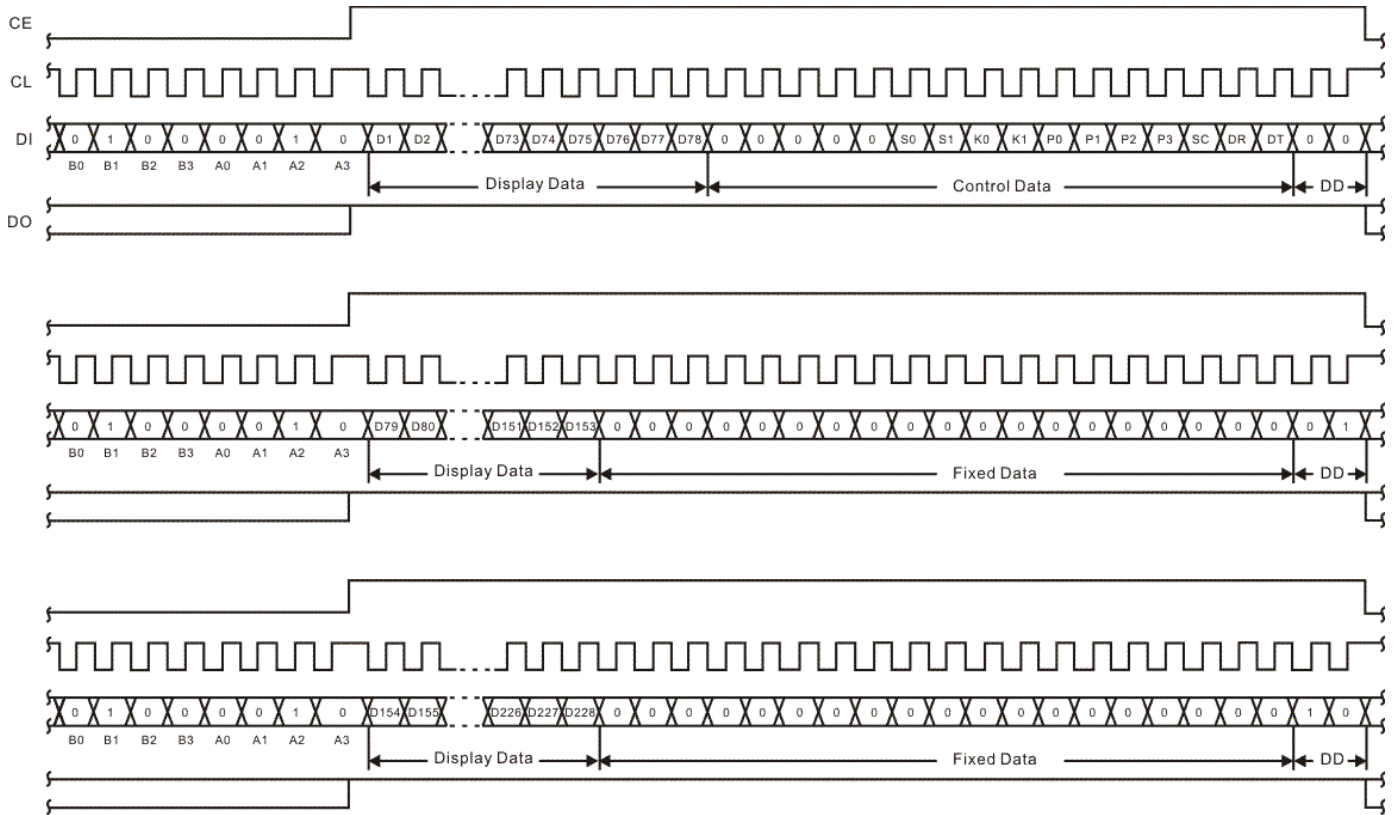

Notes:

1. B0 to B3, A0 to A3=Serial Interface address
2. DD=Direction Data

Serial Interface address: 42H

D1 to D228: Display data

S0, S1: Sleep control data

K0, K1: Key scan output/segment output selection data

P0 to P3: Segment output port/general-purpose output port selection data

SC: Segment on/off control data

DR: 1/2 bias or 1/3 bias drive selection data

DT: 1/3 duty or 1/4 duty drive selection data



6.1.2 1/4 DUTY WHEN CL IS STOPPED AT THE LOW LEVEL

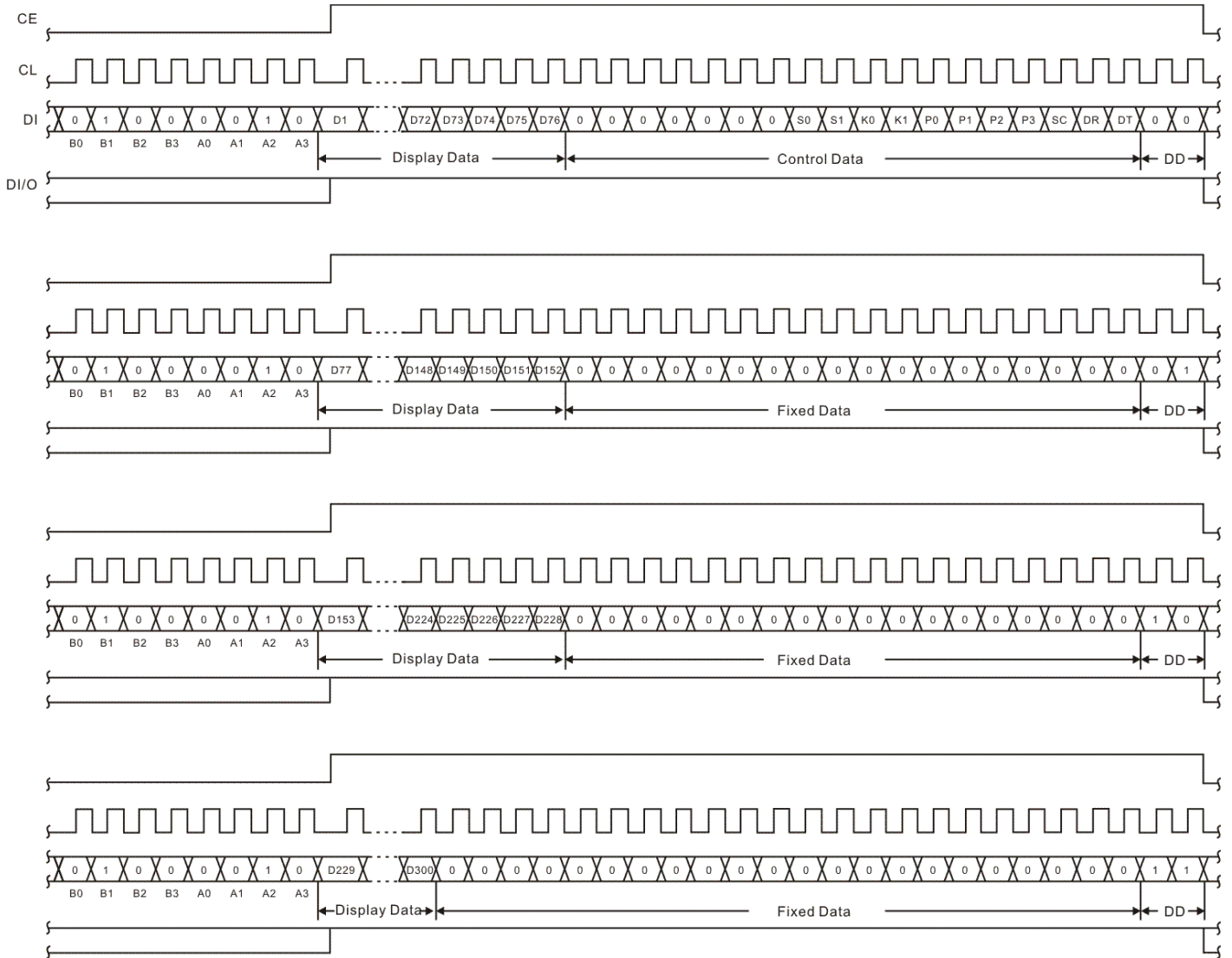

- Notes:
1. B0 to B3, A0 to A3=Serial Interface address
 2. DD=Direction Data



WHEN CL IS STOPPED AT THE HIGH LEVEL

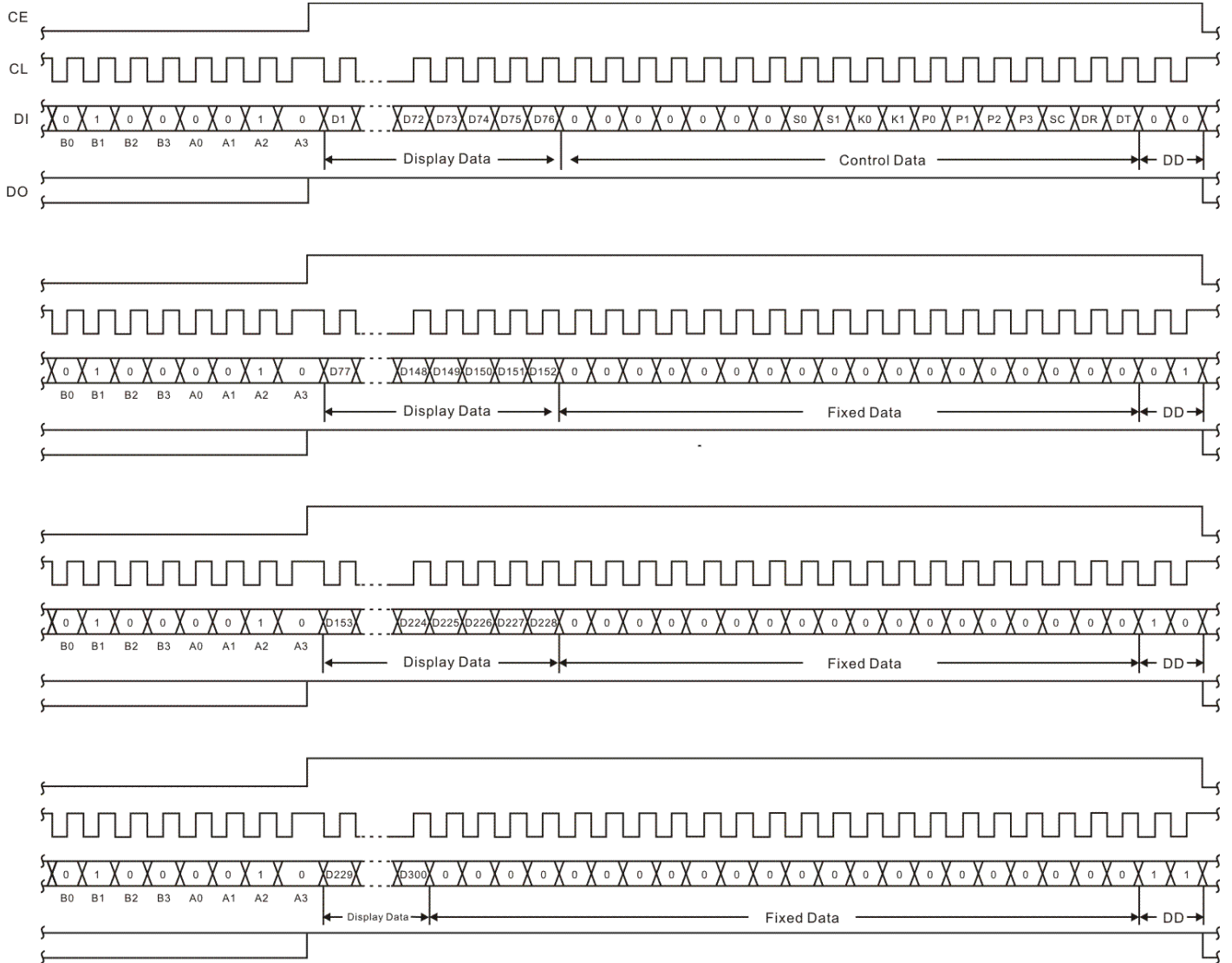

Notes:

1. B0 to B3, A0 to A3=Serial Interface address
2. DD=Direction Date

Serial interface address: 42H

D1 to D228: Display data

S0, S1: Sleep control data

K0, k1: Key scan output/segment output selection data

P0 to P3: Segment output port/general-purpose output port selection data

SC: Segment on/off control data

DR: 1/2 bias or 1/3 bias drive selection data

DT: 1/3 duty or 1/4 duty drive selection data



6.2 CONTROL DATA

6.2.1 S0, S1: SLEEP CONTROL DATA

These control data bits switch between normal mode and sleep mode and set the states of the KS1 to KS6 key scan outputs during key scan standby.

Control Data		Mode	OSC Oscillator	Segment Outputs Common Outputs	Output Pin States During Key Scan Standby					
S0	S1				KS1	KS2	KS3	KS4	KS5	KS6
0	0	Normal	Oscillator operating	Operating	H	H	H	H	H	H
0	1	Sleep	Stopped	L	L	L	L	L	L	H
1	0	Sleep	Stopped	L	L	L	L	L	H	H
1	1	Sleep	Stopped	L	H	H	H	H	H	H

Note: This assumes that the KS1/S75 and KS2/S76 output pins are selected for key scan output.

6.2.2 K0, K1: KEY SCAN OUTPUT/SEGMENT OUTPUT SELECTION DATA

These control data bits switch the functions of the KS1/S75 and KS2/S76 output pins between key scan output and segment output.

Control Data		Output Pin State		Maximum Number of Input Keys
K0	K1	KS1/S75	KS2/S76	
0	0	KS1	KS2	30
0	1	S75	KS2	25
1	X	S75	S76	20

Notes:

1. X=Don't care
2. KS_n (n=1 or 2): Key scan output
3. S_n (n=75 or 76): Segment output

6.2.3 DT: 1/3 DUTY OR 1/4 DUTY DRIVE SELECTION DATA

This control data bit switches between LCD 1/3 duty or 1/4 duty drive.

DT	Duty Drive Scheme	Output Pin State (COM4/S74)
0	1/4 duty drive	COM4
1	1/3 duty drive	S74

Notes:

1. COM4: Common output
2. S74: Segment output

6.2.4 P0 TO P3: SEGMENT OUTPUT/GENERAL-PURPOSE OUTPUT PORT SELECTION DATA

These control data bits switch the functions of the S1/P1 to S8/P8 output pins between the segment output port and the general-purpose output port.

Control Data				Output Pin State							
P0	P1	P2	P3	S1/P1	S2/P2	S3/P3	S4/P4	S5/P5	S6/P6	S7/P7	S8/P8
0	0	0	0	S1	S2	S3	S4	S5	S6	S7	S8
0	0	0	1	P1	S2	S3	S4	S5	S6	S7	S8
0	0	1	0	P1	P2	S3	S4	S5	S6	S7	S8
0	0	1	1	P1	P2	P3	S4	S5	S6	S7	S8
0	1	0	0	P1	P2	P3	P4	S5	S6	S7	S8
0	1	0	1	P1	P2	P3	P4	P5	S6	S7	S8
0	1	1	0	P1	P2	P3	P4	P5	P6	S7	S8
0	1	1	1	P1	P2	P3	P4	P5	P6	P7	S8
1	0	0	0	P1	P2	P3	P4	P5	P6	P7	P8

Notes:

1. Sn (n=1 to 8): Segment output port
2. Pn (n=1 to 8): General-purpose output port

The table below lists the correspondence between the display data and the output pins when these pins are selected to be general-purpose output ports.

Output Pin	Corresponding Display Data	
	1/3 Duty	1/4 Duty
S1/P1	D1	D1
S2/P2	D4	D5
S3/P3	D7	D9
S4/P3	D10	D13
S5/P5	D13	D17
S6/P6	D16	D21
S7/P7	D19	D25
S8/P8	D22	D29

For example, if the circuit is operated in 1/4 duty and the S4/P4 output pin is selected to be a general-purpose output port, the S4/P4 output pin will output a high level (VLCD) when the display data D13 is 1, and will output a low level (Vss) when D13 is 0.

6.2.5 SC: SEGMENT ON/OFF CONTROL DATA

This control data bit controls the on/off state of the segments.

SC	Display State
0	On
1	Off

However, note that when the segments are turned off by setting SC to 1, the segments are turned off by outputting segment off waveforms from the segment output pins.

6.2.6 DR: 1/2 BIAS OR 1/3 BIAS DRIVE SELECTION DATA

This control data bit switches between LCD 1/2 bias or 1/3 bias drive.

DR	Bias Drive Scheme
0	1/3 bias drive
1	1/2 bias drive

6.3 DISPLAY DATA AND OUTPUT PI CORRESPONDENCE

6.3.1 1/3 DUTY

Output Pin	COM1	COM2	COM3	Output Pin	COM1	COM2	COM3	Output Pin	COM1	COM2	COM3
S1/P1	D1	D2	D3	S27	D79	D80	D81	S53	D157	D158	D159
S2/P2	D4	D5	D6	S28	D82	D83	D84	S54	D160	D161	D162
S3/P3	D7	D8	D9	S29	D85	D86	D87	S55	D163	D164	D165
S4/P4	D10	D11	D12	S30	D88	D89	D90	S56	D166	D167	D168
S5/P5	D13	D14	D15	S31	D91	D92	D93	S57	D169	D170	D171
S6/P6	D16	D17	D18	S32	D94	D95	D96	S58	D172	D173	D174
S7/P7	D19	D20	D21	S33	D97	D98	D99	S59	D175	D176	D177
S8/P8	D22	D23	D24	S34	D100	D101	D102	S60	D178	D179	D180
S9	D25	D26	D27	S35	D103	D104	D105	S61	D181	D182	D183
S10	D28	D29	D30	S36	D106	D107	D108	S62	D184	D185	D186
S11	D31	D32	D33	S37	D109	D110	D111	S63	D187	D188	D189
S12	D34	D35	D36	S38	D112	D113	D114	S64	D190	D191	D192
S13	D37	D38	D39	S39	D115	D116	D117	S65	D193	D194	D195
S14	D40	D41	D42	S40	D118	D119	D120	S66	D196	D197	D198
S15	D43	D44	D45	S41	D121	D122	D123	S67	D199	D200	D201
S16	D46	D47	D48	S42	D124	D125	D126	S68	D202	D203	D204
S17	D49	D50	D51	S43	D127	D128	D129	S69	D205	D206	D207
S18	D52	D53	D54	S44	D130	D131	D132	S70	D208	D209	D210
S19	D55	D56	D57	S45	D133	D134	D135	S71	D211	D212	D213
S20	D58	D59	D60	S46	D136	D137	D138	S72	D214	D215	D216
S21	D61	D62	D63	S47	D139	D140	D141	S73	D217	D218	D219
S22	D64	D65	D66	S48	D142	D143	D144	COM4/S74	D220	D221	D222
S23	D67	D68	D69	S49	D145	D146	D147	KS1/S75	D223	D224	D225
S24	D70	D71	D72	S50	D148	D149	D150	KS2/S76	D226	D227	D228
S25	D73	D74	D75	S51	D151	D152	D153				
S26	D76	D77	D78	S52	D154	D155	D156				

Note: This is for the case where the output pins S1/P1 to S8/P8, COM4/S74, KS1/S75 and KS2/S76 are selected for use as segment outputs.

For example, the table below lists the operation of the S11 segment output pin.

Display Data			Output Pin State (S11)
D31	D32	D33	
0	0	0	The LCD segments for COM1, COM2 and COM3 are off.
0	0	1	The LCD segment for COM3 is on.
0	1	0	The LCD segment for COM2 is on.
0	1	1	The LCD segments for COM2 and COM3 are on.
1	0	0	The LCD segment for COM1 is on.
1	0	1	The LCD segments for COM 1 and COM3 are on.
1	1	0	The LCD segments for COM1 and COM2 are on.
1	1	1	The LCD segments for COM1, COM2 and COM3 are on.



6.3.2 1/4 DUTY

Output Pin	COM1	COM2	COM3	COM4
S1/P1	D1	D2	D3	D4
S2/P2	D5	D6	D7	D8
S3/P3	D9	D10	D11	D12
S4/P4	D13	D14	D15	D16
S5/P5	D17	D18	D19	D20
S6/P6	D21	D22	D23	D24
S7/P7	D25	D26	D27	D28
S8/P8	D29	D30	D31	D32
S9	D33	D34	D35	D36
S10	D37	D38	D39	D40
S11	D41	D42	D43	D44
S12	D45	D46	D47	D48
S13	D49	D50	D51	D52
S14	D53	D54	D55	D56
S15	D57	D58	D59	D60
S16	D61	D62	D63	D64
S17	D65	D66	D67	D68
S18	D69	D70	D71	D72
S19	D73	D74	D75	D76
S20	D77	D78	D79	D80
S21	D81	D82	D83	D84
S22	D85	D86	D87	D88
S23	D89	D90	D91	D92
S24	D93	D94	D95	D96
S25	D97	D98	D99	D100
S26	D101	D102	D103	D104
S27	D105	D106	D107	D108
S28	D109	D110	D111	D112
S29	D113	D114	D115	D116
S30	D117	D118	D119	D120
S31	D121	D122	D123	D124
S32	D125	D126	D127	D128
S33	D129	D130	D131	D132
S34	D133	D134	D135	D136
S35	D137	D138	D139	D140
S36	D141	D142	D143	D144
S37	D145	D146	D147	D148
S38	D149	D150	D151	D152

Output Pin	COM1	COM2	COM3	COM4
S39	D153	D154	D155	D156
S40	D157	D158	D159	D160
S41	D161	D162	D163	D164
S42	D165	D166	D167	D168
S43	D169	D170	D171	D172
S44	D173	D174	D175	D176
S45	D177	D178	D179	D180
S46	D181	D182	D183	D184
S47	D185	D186	D187	D188
S48	D189	D190	D191	D192
S49	D193	D194	D195	D196
S50	D197	D198	D199	D200
S51	D201	D202	D203	D204
S52	D205	D206	D207	D208
S53	D209	D210	D211	D212
S54	D213	D214	D215	D216
S55	D217	D218	D219	D220
S56	D221	D222	D223	D224
S57	D225	D226	D227	D228
S58	D229	D230	D231	D232
S59	D233	D234	D235	D236
S60	D237	D238	D239	D240
S61	D241	D242	D243	D244
S62	D245	D246	D247	D248
S63	D249	D250	D251	D252
S64	D453	D254	D255	D256
S65	D257	D258	D259	D260
S66	D261	D262	D263	D264
S67	D265	D266	D267	D268
S68	D269	D270	D271	D272
S69	D273	D274	D275	D276
S70	D277	D278	D279	D280
S71	D281	D282	D283	D284
S72	D285	D286	D287	D288
S73	D289	D290	D291	D292
KS1/S75	D293	D294	D295	D296
KS2/S76	D297	D298	D299	D300

Note: This is for the case where the output pins S1/P1 to S8/P8, KS1/S75 and KS2/S76 are selected for use as segment outputs.

For example, the table below lists the segment output states for the S11 output pin.

Display Data				Output Pin State (S11)
D41	D42	D43	D44	
0	0	0	0	The LCD segment for COM1, COM2, COM3 and COM4 are off.
0	0	0	1	The LCD segment for COM4 is on.
0	0	1	0	The LCD segment for COM3 is on.
0	0	1	1	The LCD segments for COM3 and COM4 are on.
0	1	0	0	The LCD segment for COM2 is on.
0	1	0	1	The LCD segments for COM2 and COM4 are on.
0	1	1	0	The LCD segments for COM2 and COM3 are on.
0	1	1	1	The LCD segments for COM2, COM3 and COM4 are on.
1	0	0	0	The LCD segment for COM1 is on.
1	0	0	1	The LCD segments for COM1 and COM4 are on.
1	0	1	0	The LCD segments for COM1 and COM3 are on.
1	0	1	1	The LCD segments for COM1, COM3 and COM4 are on.
1	1	0	0	The LCD segments for COM1 and COM2 are on.
1	1	0	1	The LCD segments for COM1, COM2 and COM4 are on.
1	1	1	0	The LCD segments for COM1, COM2 and COM3 are on.
1	1	1	1	The LCD segments for COM1, COM2, COM3 and COM4 are on.

6.4 SERIAL DATA OUTPUT

WHEN CL IS STOPPED AT THE LOW LEVEL

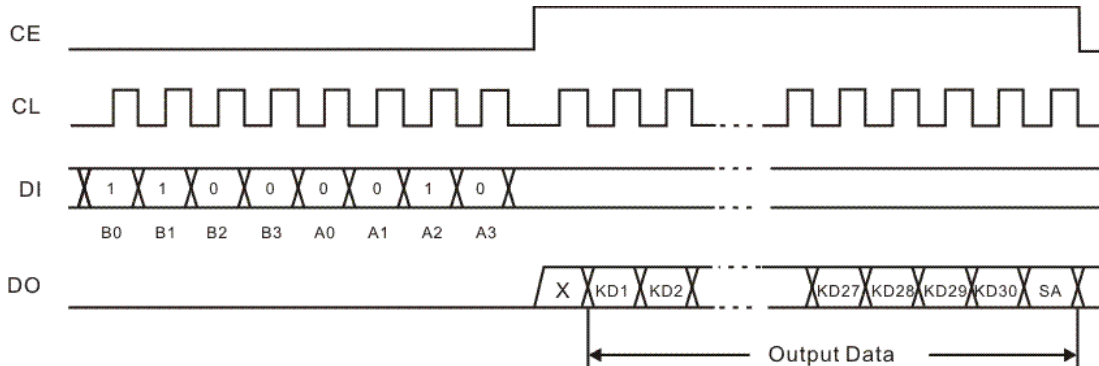

Notes:

1. X=Don't care
2. B0 to B3, A0 to A3: Serial Interface address

WHEN CL IS STOPPED AT THE HIGH LEVEL

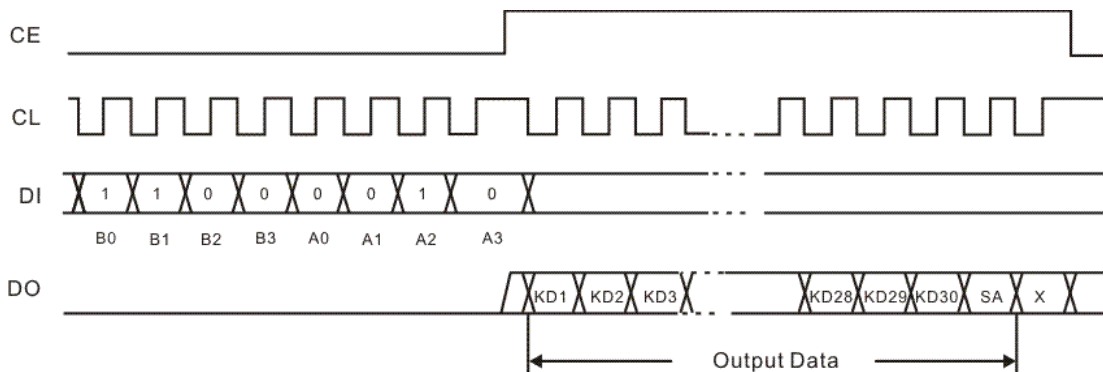

Notes:

1. X=Don't care
2. B0 to B3, A0 to A3: Serial Interface address
3. Serial Interface address: 43H
4. KD1 to KD30: Key data
5. SA: Sleep acknowledge data
6. If a key data read operation is executed when DO is high, the read key data (KD1 to KD30) and sleep acknowledge data (SA) will be invalid.

6.5 OUTPUT DATA

6.5.1 KD1 TO KD30: KEY DATA

When a key matrix of up to 30 keys is formed from the KS1 to KS6 output pins and the KI1 to KI5 input pins and one of those keys is pressed, the key output data corresponding to that key will be set to 1. The table shows the relationship between those pins and the key data bits.

Item	KI1	KI2	KI3	KI4	KI5
KS1/S75	KD1	KD2	KD3	KD4	KD5
KS2/S76	KD6	KD7	KD8	KD9	KD10
KS3	KD11	KD12	KD13	KD14	KD15
KS4	KD16	KD17	KD18	KD19	KD20
KS5	KD21	KD22	KD23	KD24	KD25
KS6	KD26	KD27	KD28	KD29	KD30

When the KS1/S75 and KS2/S76 output pins are selected to be segment outputs by control data bits K0 and K1 and a key matrix of up to 20 keys is formed using the KS3 to KS6 output pins and the KI1 to KI5 input pins, the KD1 to KD10 key data bits will be set to 0.

6.5.2 SA: SLEEP ACKNOWLEDGE DATA

This output data is set to the state when the key was pressed. In that case DO will go to the low level. If serial data is input during this period and the mode is set (normal mode or sleep mode), the IC will be set to that mode. SA is set to 1 in the sleep mode and to 0 in the normal mode.

6.6 SLEEP MODE

Sleep mode is set up by setting S0 or S1 in the control data to 1. The segment outputs will all go low and the common outputs will also go low, and the oscillator on the OSC pin will stop (it will be started by a key press). This reduces power dissipation. This mode is cleared by sending control data with both S0 and S1 set to 0. However, note that the S1/P1 to S8/P8 outputs can be used as general-purpose output ports according to the state of the P0 to P3 control data bits, even in sleep mode. (See the control data description for details.)

6.7 KEY SCAN OPERATION FUNCTIONS

6.7.1 KEY SCAN TIMING

The key scan period is $288T(s)$. To reliably determine the on/off state of the keys, the PT6530 scans the keys twice and determines that a key has been pressed when the key data agrees. It outputs a key data read request (a low level on DO) $615T(s)$ after starting a key scan. If the key data does not agree and a key was pressed at that point, it scans the keys again. Thus the PT6530 cannot detect a key press shorter than $615T(s)$.

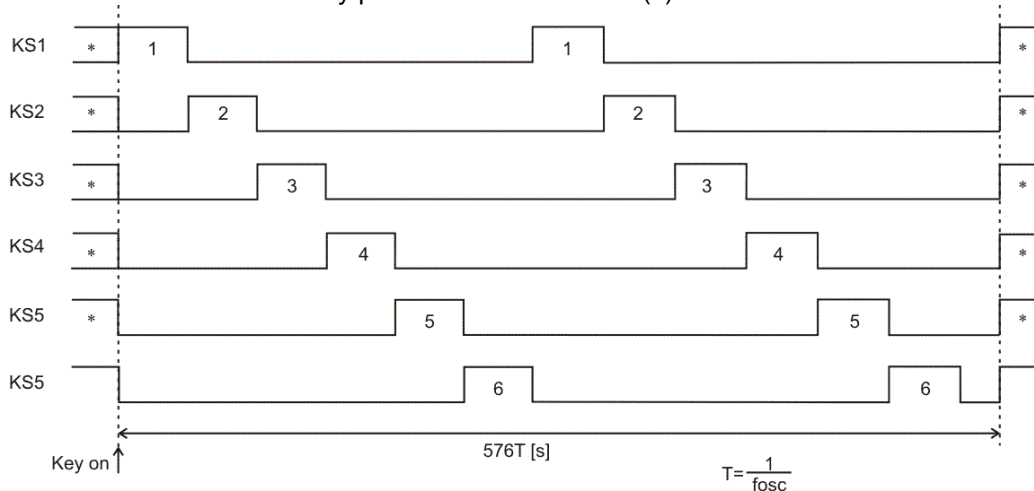

Note:

*: In sleep mode the high/low state of these pins is determined by the S0 and S1 bits in the control data. Key scan output signals are not output from pins that are set low.

6.7.2 IN NORMAL MODE

- The pins KS1 to KS6 are set high.
- When a key is pressed a key scan is started and the keys are scanned until all keys are released. Multiple key presses are recognized by determining whether multiple key data bits are set.
- If a key is pressed for longer than $615T(s)$ (Where $T = \frac{1}{fosc}$) the PT6530 outputs a key data read request (a low level on DO) to the controller. The controller acknowledges this request and reads the key data. However, if CE is high during a serial data transfer, DO will be set high.

level on DO) to the controller. The controller acknowledges this request and reads the key data. However, if CE is high during a serial data transfer, DO will be set high.

After the controller reads the key data, the key data read request is cleared (DO is set high) and the PT6530 performs another key scan. Also note that DO, being an open-drain output, requires a pull-up resistor (between 1 and 10K Ω).

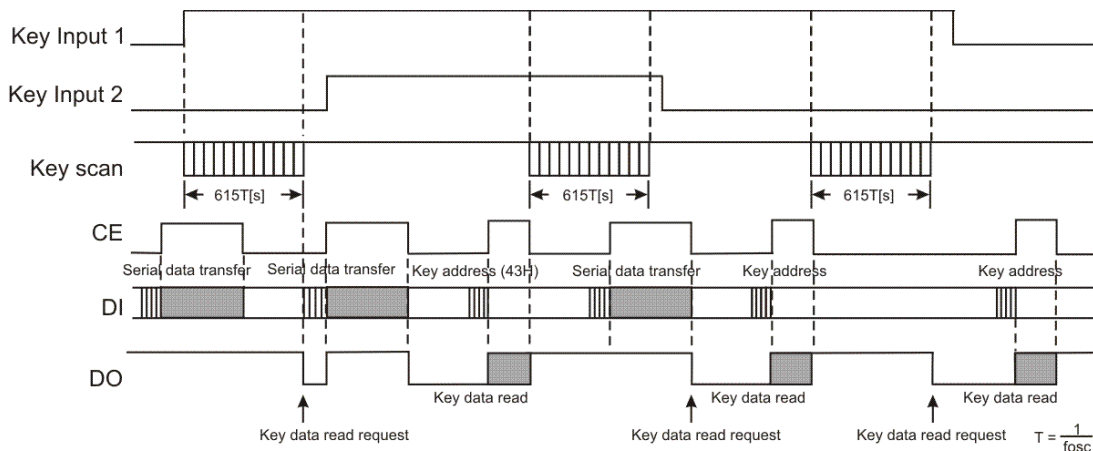

6.7.3 IN SLEEP MODE

- The pins KS1 to KS6 are set to high or low by the S0 and S1 bits in the control data. (See the control data description for details.)
- If a key on one of the lines corresponding to a KS1 to KS6 pin which is set high is pressed, the oscillator on the OSC pin is started and a key scan is performed. Keys are scanned until all keys are released. Multiple key presses are recognized by determining whether multiple key data bits are set.
- If a key is pressed for longer than $615T$ (s)(Where $T = \frac{1}{f_{osc}}$) the PT6530 outputs a key data read request (a low level on DO) to the controller. The controller acknowledges this request and reads the key data. However, if CE is high during a serial data transfer, DO will be set high.
- After the controller reads the key data, the key data read request is cleared (DO is set high) and the PT6530 performs another key scan. However, this does not clear sleep mode. Also note that DO, being an open-drain output, requires a pull-up resistor (between 1 and 10KΩ).
- Sleep mode key scan example

Example: S0=0, S1=1 (sleep with only KS6 high)

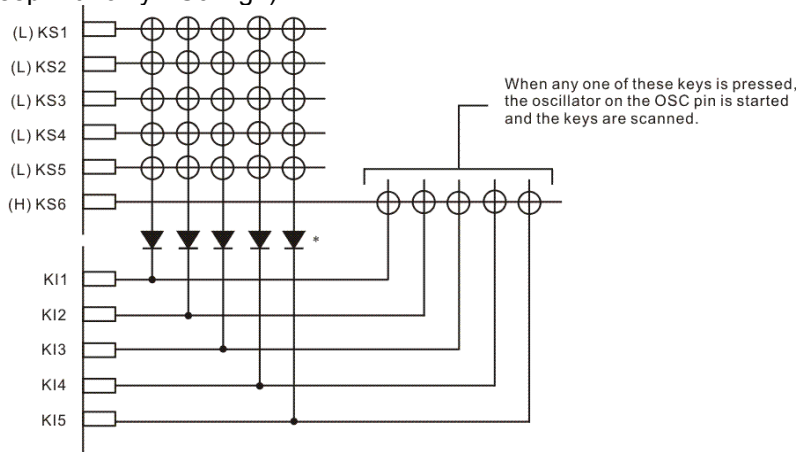

Note:

*: These diodes are required to reliably recognize multiple key presses on the KS6 line when sleep mode state with only KS6 high, as in the above example. That is, these diodes prevent incorrect operations due to sneak currents in the KS6 key scan output signal when keys on the KS1 to KS5 lines are pressed at the same time.

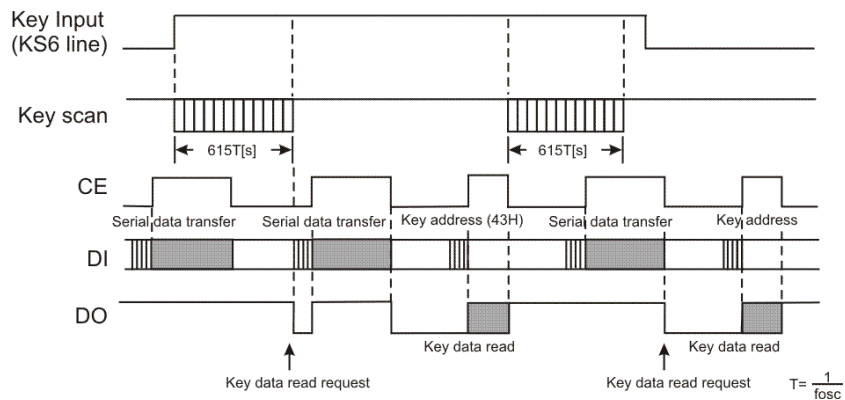

6.8 MULTIPLE KEY PRESSES

Although the PT6530 is capable of key scanning without inserting diodes for dual key presses, triple key presses on the K11 to K15 input pin lines, or multiple key presses on the KS1 to KS6 output pin lines, multiple presses other than these cases may result in keys that were not pressed recognized as having been pressed. Therefore, a diode must be inserted in series with each key. Applications that do not recognize multiple key presses of three or more keys should check the key data for three or more 1 bit and ignore such data.

6.9 1/3 DUTY, 1/2 BIAS DRIVE TECHNIQUE

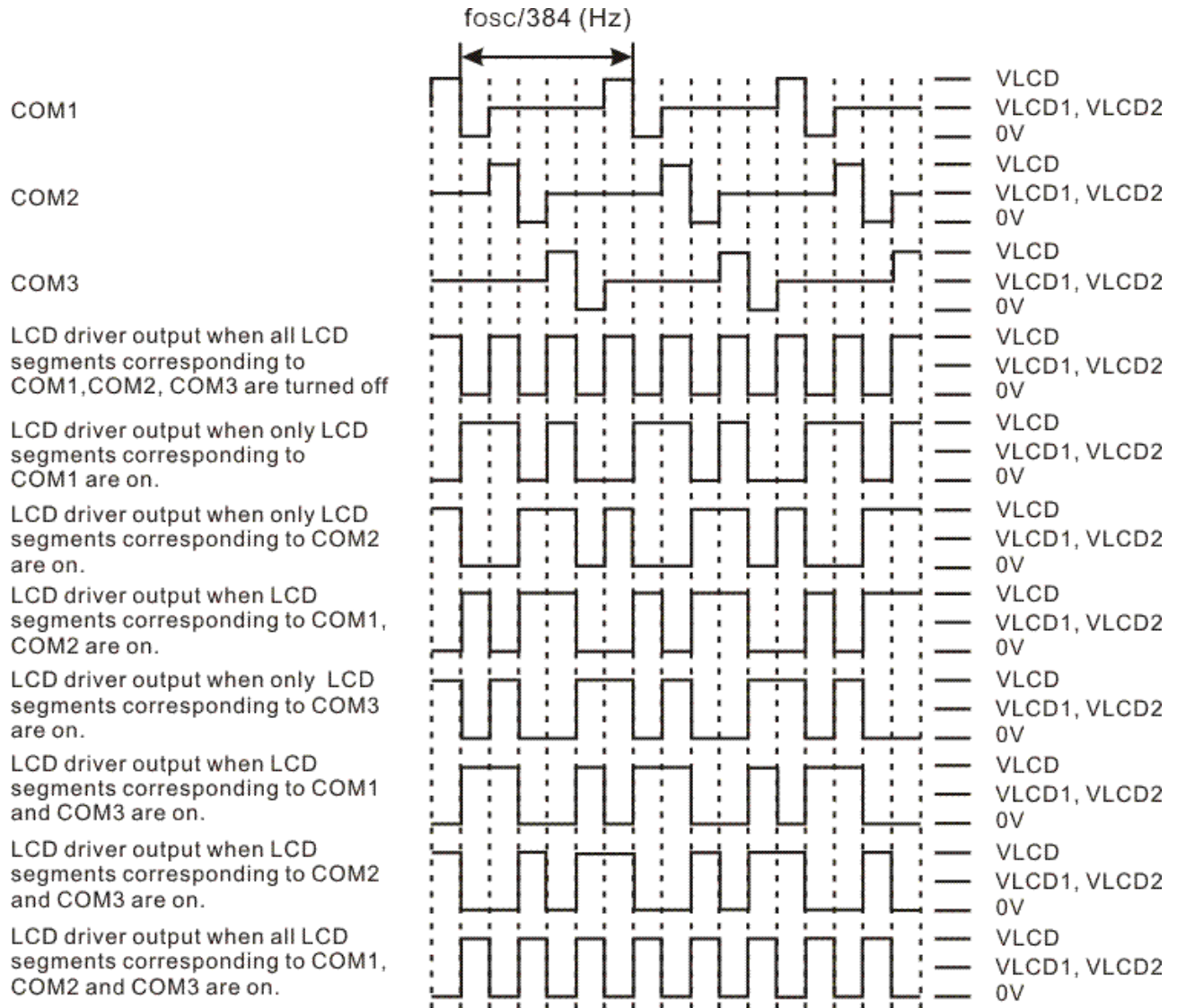

6.10 1/3 DUTY, 1/3 BIAS DRIVE TECHNIQUE

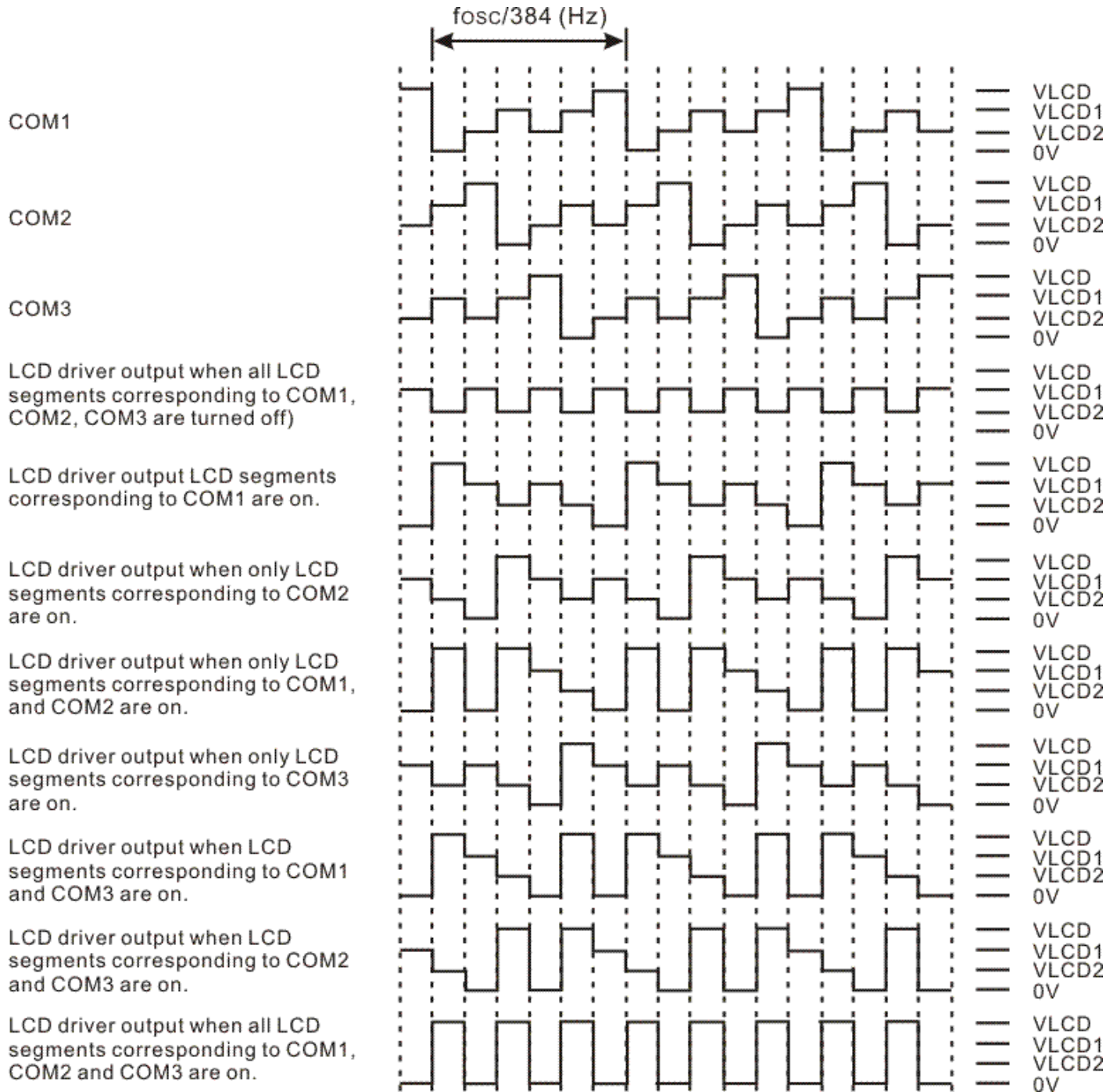

6.11 1/4 DUTY, 1/2 BIAS DRIVE TECHNIQUE

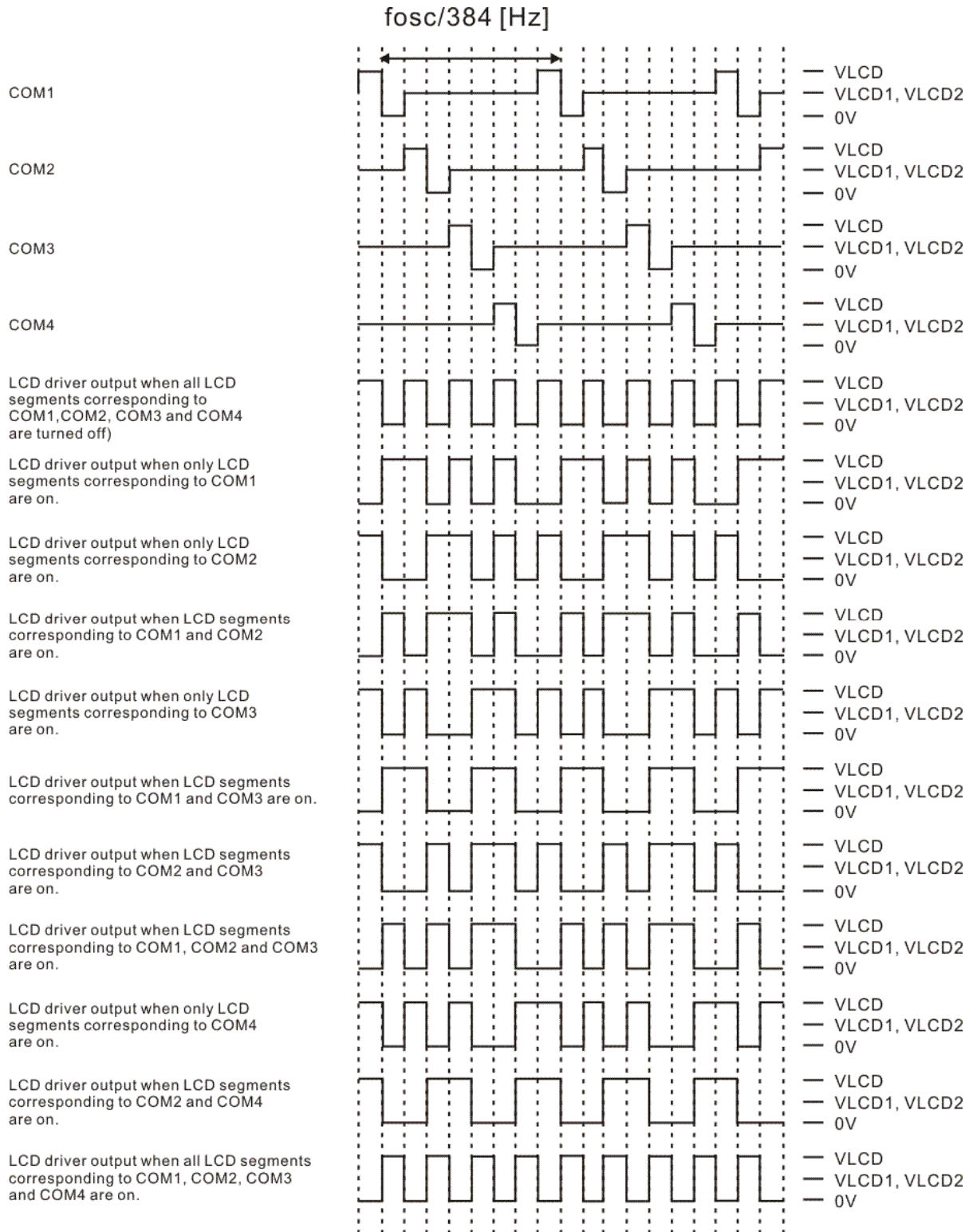

6.12 1/4 DUTY, 1/3 BIAS DRIVE TECHNIQUE

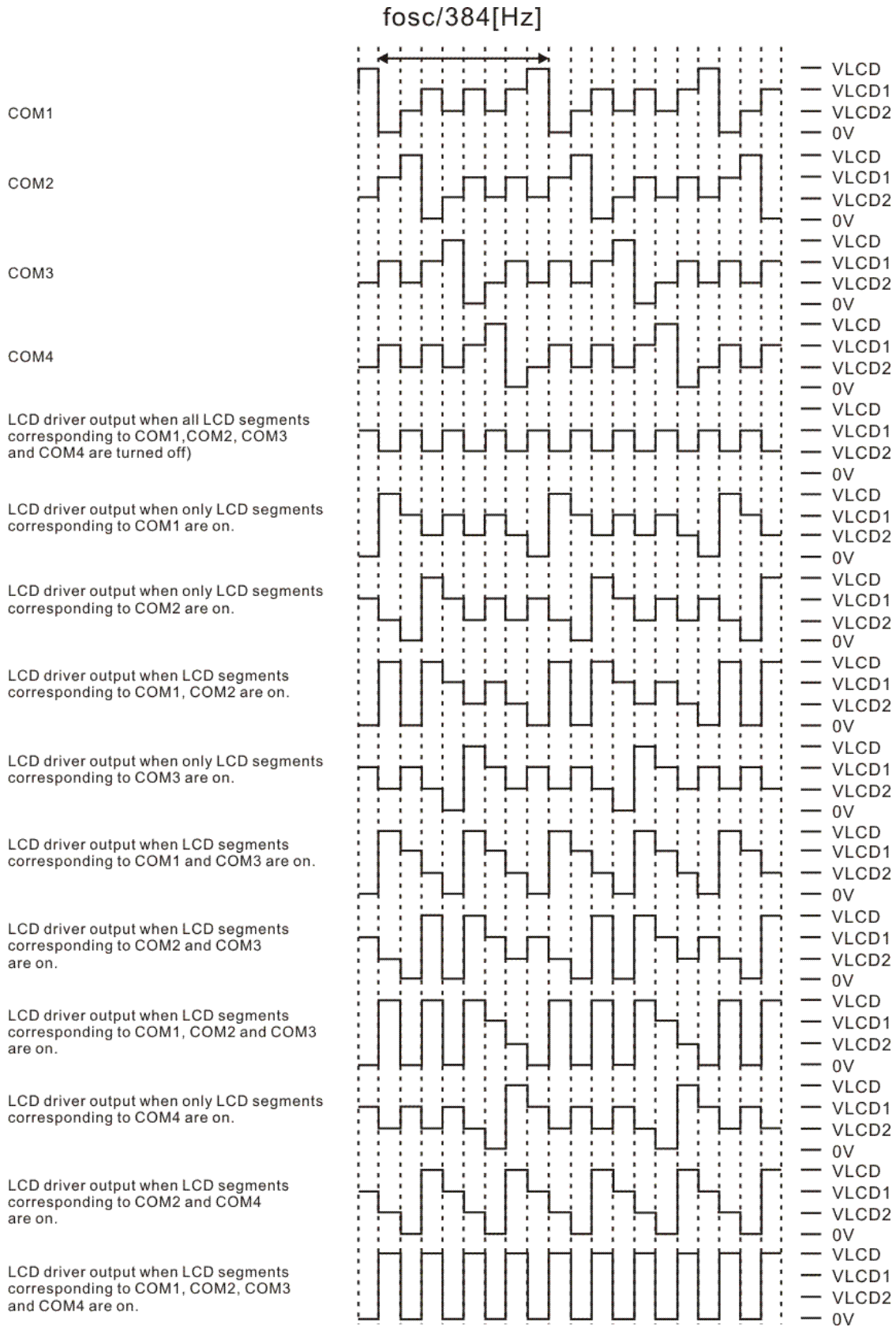

6.13 VOLTAGE DETECTION TYPE RESET CIRCUIT (VDET)

This circuit generates an output signal and resets the system when logic block power is first applied and when the voltage drops, i.e., when the logic block power supply voltage is less than or equal to the power down detection voltage VDET, which is 2.3V, typical. To assure that this function operates reliably, a capacitor must be added to the logic block power supply line so that the logic block power supply voltage VDD rise time when the logic block power is first applied and the logic block power supply voltage VDD fall time when the voltage drops are both at least 1ms. (see Figure 1 and Figure 2.)

6.14 POWER SUPPLY SEQUENCE

The following sequences must be observed when power is turned on and off. (see Figure 1 and Figure 2.)

- Power on: Logic block power supply(VDD) on → LCD driver block power supply(VLCD) on.
- Power off: LCD driver block power supply(VLCD) off → Logic block power supply(VDD) off.

However, if the logic and LCD driver block use a shared power supply, then the power supplies can be turned on and off at the same time.

6.15 SYSTEM RESET

The PT6530 supports the reset methods described below. When a system reset is applied, display is turned off, key scanning is stopped, and all the key data is reset to low. When the reset is cleared, display is turned on and key scanning become possible.

6.15.1 RESET METHODS

(1) Reset at power-on and power-down

If at least 1ms is assured as the logic block supply voltage VDD rise time when logic block power is applied, a system reset will be applied by the VDET output signal when the logic block supply voltage is brought up. If at least 1ms is assured as the logic block supply voltage VDD fall time when logic block power drops, a system reset will be applied in the same manner by the VDET output signal when the supply voltage is lowered. Note that the reset is cleared at the point when all the serial data (1/3 duty: the display data D1 to D228 and the control data, 1/4 duty: the display data D1 to D300 and the control data) has been transferred, i.e., on the fall of the CE signal on the transfer of the last direction data, after all the direction data has been transferred. However, the above operations will be performed regardless of the state (high or low) of the /RES pin. If /RES is high, the reset will be cleared at the point the above operations are completed. On the other hand, if /RES is low, the system will remain in the reset period as long as /RES is not set high, even if the above operations are completed. (see Figure 1 and Figure 2.)

(2) Reset when the logic block power supply voltage is in the allowable operating range (VDD=3.0 to 6.0V).
The system is reset when the /RES pin is set low, and the reset is cleared by setting /RES pin high.

1/3 DUTY

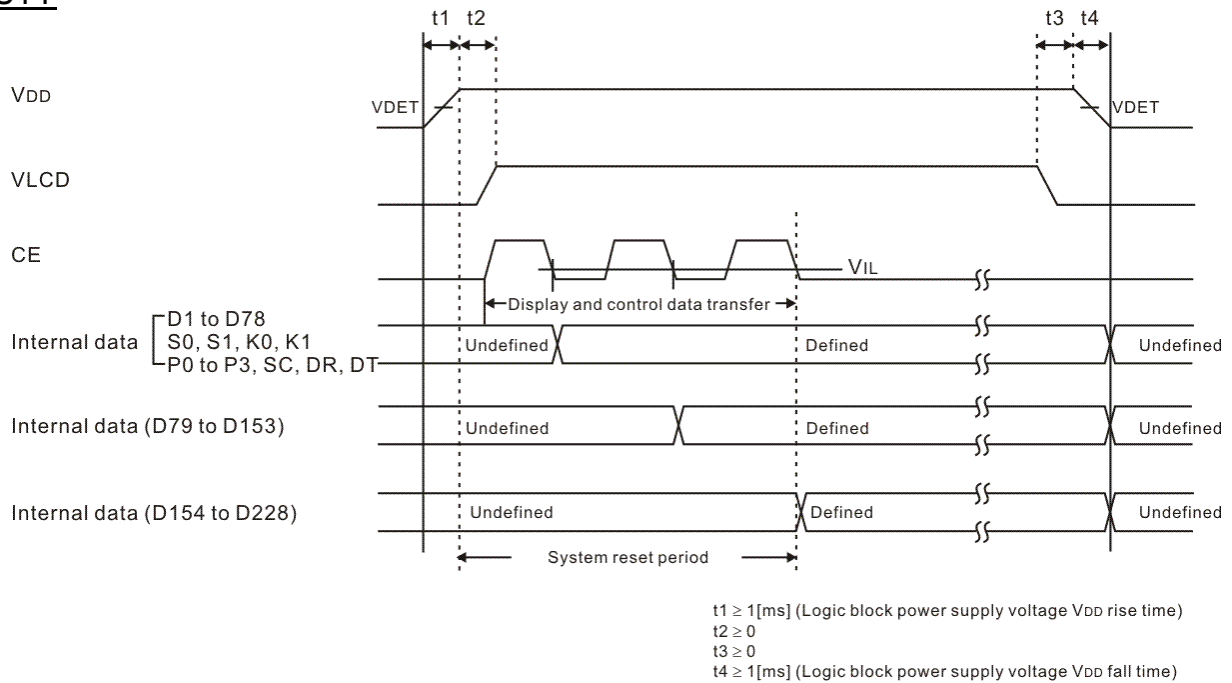

Figure 1

1/4 DUTY

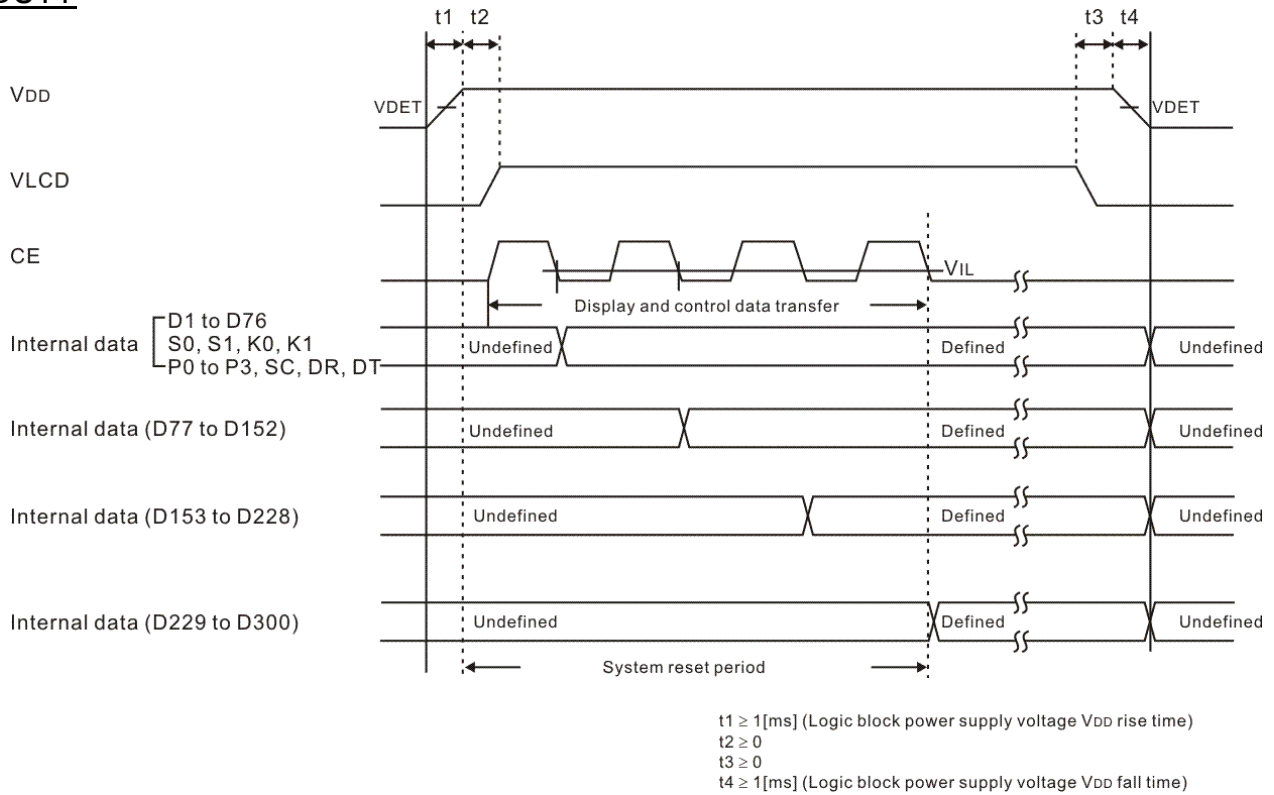

Figure 2

6.15.2 PT6530 INTERNAL BLOCK STATES DURING THE RESET PERIOD

- Clock Generator

Reset is applied and the base clock is stopped. However, the OSC pin state (normal or sleep mode) is determined after the S0 and S1 control data bits are transferred.

- Common Diver, Segment Driver & Latch

Reset is applied and the display is turned off. However, display data can be input to the latch circuit in this state.

- Key Scan

Reset is applied, the circuit is set to the initial state, and at the same time the key scan operation is disabled.

- Key Buffer

Reset is applied and all the key data is set to low.

- Serial Interface, Control Register, Shift Register

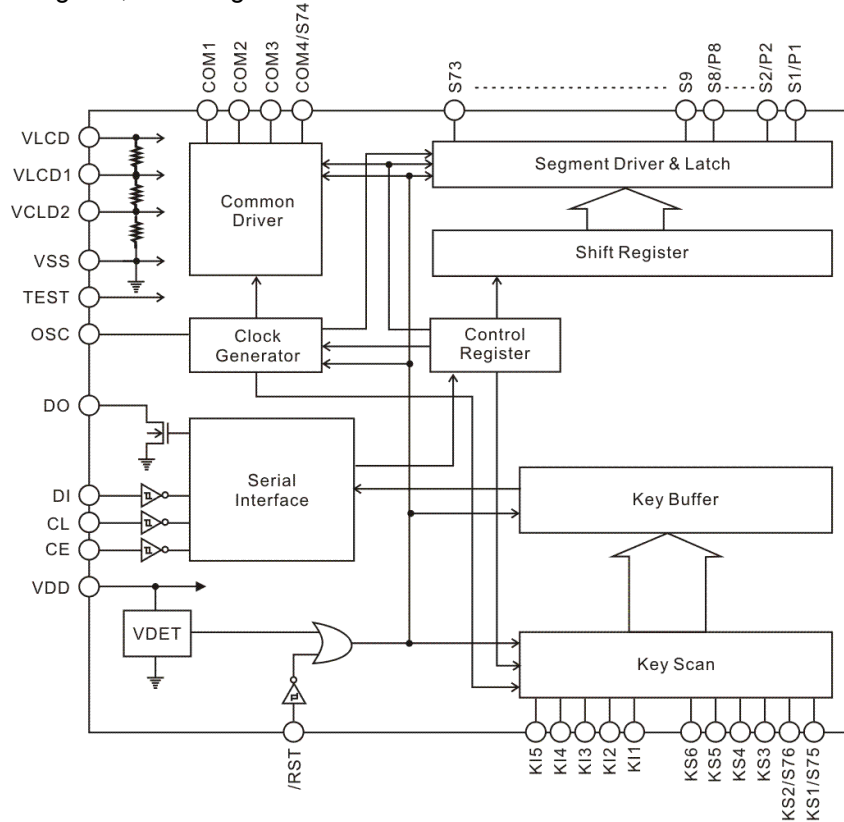

Block that are reset

6.15.3 OUTPUT PIN STATES DURING THE RESET PERIOD

Output Pin	State During Reset
S1/P1 to S8/P8	L (Note 2)
S9 to S73	L
COM1 to COM3	L
COM4/S74	L (Note 3)
KS1/S75. KS2/S76	L (Note 2)
KS3 to KS5	X (Note 4)
KS6	H
DO	H (Note 5)

Notes:

1. X = Don't care
2. These output pins are forcibly set to the segment output function and held low.
3. When power is first applied, this output pin is forcibly set to the common output function and held low. However, when the DT control data bit is transferred, either the common output or the segment output function is selected.
4. When power is first applied, these output pins are undefined until the S0 and S1 control data bits have been transferred.
5. Since this output pin is an open-drain output, a pull-up resistor of between 1 and 10KΩ is required. This pin remains high during the reset period even if a key data read operation is performed.

6.16 NOTE ON TRANSFERRING DISPLAY DATA FROM THE CONTROLLER

When using the PT6530 in 1/3 duty, applications transfer the display data (D1 to D228) in three operations, and in 1/4 duty, they transfer the display data (D1 to D300) in four operations. In either case, applications should transfer all of the display data within 30ms to maintain the quality of the displayed image.

6.17 NOTE ON THE CONTROLLER KEY DATA READ TECHNIQUES

6.17.1 TIMER BASED KEY DATA ACQUISITION

FLOWCHART

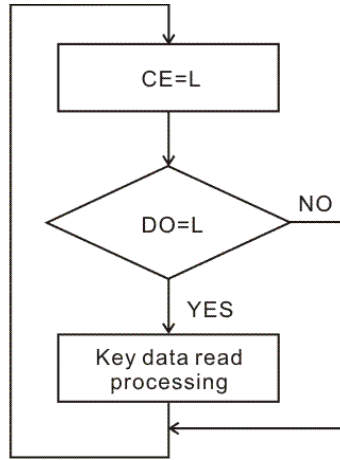

TIMING CHART

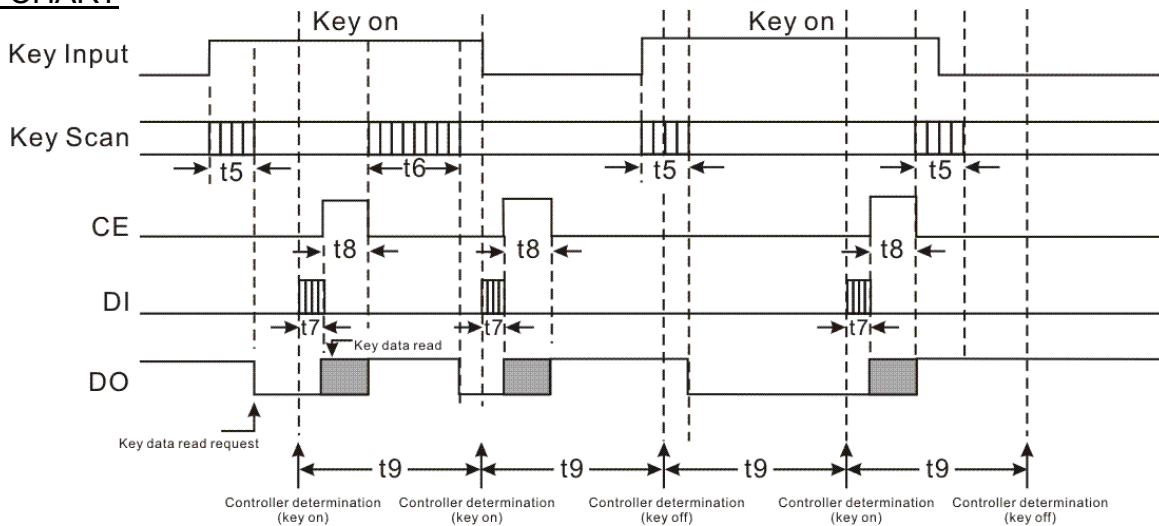

t5: Key scan execution time when the key data agreed for two key scans. (615T(s))

t6: Key scan execution time when the key data did not agree for two key scans and the key scan was executed again. (1230T(s))

t7: Key address (43H) transfer time $T = \frac{1}{f_{osc}}$

t8: Key data read time

EXPLANATION

In this technique, the controller uses a timer to determine key on/off states and read the key data. The controller must check the DO state when CE is low every t9 period without fail. If DO is low, the controller recognizes that a key has been pressed and executes the key data read operation.

The period t9 in this technique must satisfy the following condition.

$$t9 > t6 + t7 + t8$$

If a key data read operation is executed when DO is high, the read key data (KD1 to KD30) and sleep acknowledge data (SA) will be invalid.

6.17.2 INTERRUPT BASED KEY DATA ACQUISITION FLOWCHART

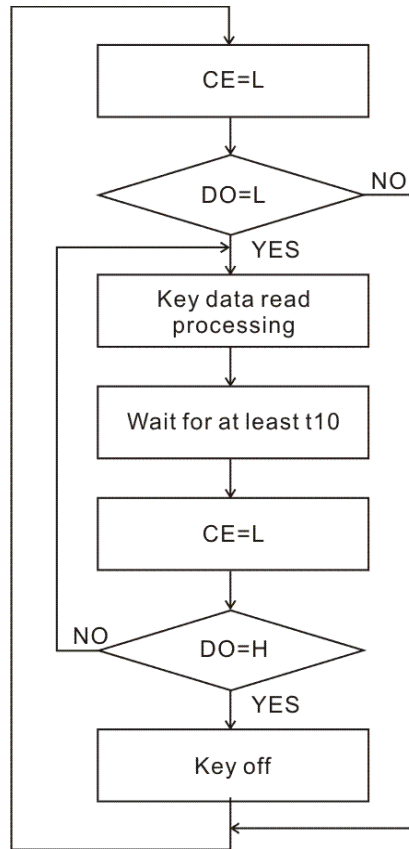

TIMING CHART

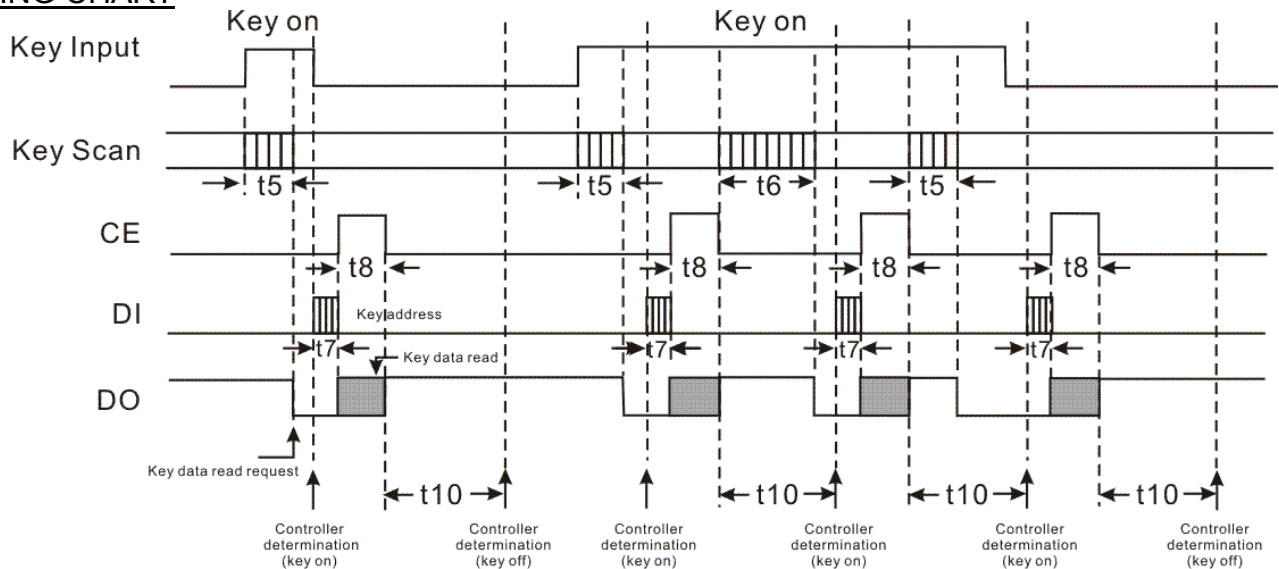

t5: Key scan execution time when the key data agreed for two key scans. (615T(s))

t6: Key scan execution time when the key data did not agree for two key scans and the key scan was executed again. (1230T(s))

t7: Key address (43H) transfer time $T = \frac{1}{f_{osc}}$

t8: Key data read time

EXPLANATION

In this technique, the controller uses interrupts to determine key on/off states and read the key data. The controller must check the DO state when CE is low. If DO is low, the controller recognizes that a key has been pressed and executes the key data read operation. After that the next key on/off determination is performed after the time t10 has elapsed by checking the DO state when CE is low and reading the key data. The period t10 in this technique must satisfy the following condition.

$$t10 > t6$$

If a key data read operation is executed when DO is high, the read key data (KD1 to KD30) and sleep acknowledge data (SA) will be invalid.

7. ABSOLUTE MAXIMUM RATINGS

(VSS=0V, Ta=25°C)

Parameter	Symbol	Condition	Rating	Unit
Maximum Supply Voltage	V _{DD} max	V _{DD}	-0.3 ~ +7.0	V
	V _{LCD} max	V _{LCD}	-0.3 ~ +7.0	
Input Voltage	V _{IN1}	CE, CL, DI, /RES	-0.3 ~ V _{DD} +0.3	V
	V _{IN2}	OSC, TEST	-0.3 ~ V _{DD} +0.3	
	V _{IN3}	V _{LCD1} , V _{LCD2} , KI1 to KI5	-0.3 ~ V _{LCD} +0.3	
Output Voltage	V _{OUT1}	DO	-0.3 ~ V _{DD} +0.3	V
	V _{OUT2}	OSC	-0.3 ~ V _{DD} +0.3	
	V _{OUT3}	S1 to S76, COM1 to COM4, KS1 to KS6, P1 to P8	-0.3 ~ V _{LCD} +0.3	
Output Current	I _{OUT1}	S1 to S76	300	μA
	I _{OUT2}	COM1 to COM4	3	mA
	I _{OUT3}	KS1 to KS6	1	
	I _{OUT4}	P1 to P8	5	
Allowable Power Dissipation	Pd max	Ta = 85°C	200	mW
Operating Temperature	Topr	-	-40 ~ +85	°C
Storage Temperature	Tstg	-	-65 ~ +150	°C

8. ALLOWABLE OPERATING RANGES

(Ta=-40 to +85°C, VSS=0V)

Parameter	Symbol	Condition	Min	Typ	Max	Unit
Supply Voltage	V _{DD}	V _{DD}	3	-	6.0	V
	V _{LCD}	V _{LCD}	V _{DD} -0.5	-	6.0	V
Input Voltage	V _{LCD1}	V _{LCD1}	-	2/3V _{LCD}	V _{LCD}	V
	V _{LCD2}	V _{LCD2}	-	1/3V _{LCD}	V _{LCD}	V
Input High-Level Voltage	V _{IH1}	CE, CL, DI, /RES	0.8 V _{DD}	-	V _{DD}	V
	V _{IH2}	KI1 to KI5	0.6 V _{LCD}	-	V _{LCD}	V
Input Low Level Voltage	V _{IL}	CE, CL, DI, /RES, (KI1 to KI5)	0	-	0.2 V _{DD} (0.2V _{LCD})	V
Recommended External Resistance	R _{OSC}	OSC	-	39	-	KΩ
Recommended External Capacitance	C _{OSC}	OSC	-	1000	-	pF
Guaranteed Oscillator Range	f _{osc}	OSC	19	38	76	KHz
Data Setup Time	t _{ds}	CL, DI: Figure 4	160	-	-	ns
Data Hold Time	t _{dh}	CL, DI: Figure 4	160	-	-	ns
CE Wait Time	t _{cp}	CE, CL: Figure 4	160	-	-	ns
CE Setup Time	t _{cs}	CE, CL: Figure 4	160	-	-	ns
CE Hold Time	t _{ch}	CE, CL: Figure 4	160	-	-	ns
High Level Clock Pulse Width	t _{∅H}	CL: Figure 4	160	-	-	ns
Low Level Clock Pulse Width	t _{∅L}	CL: Figure 4	160	-	-	ns
Rise Time	t _r	CE, CL, DI: Figure 4	-	160	-	ns
Fall Time	t _f	CE, CL, DI: Figure 4	-	160	-	ns
DO Output Delay Time	t _{dc}	DO, R _{PU} =4.7KΩ, C _L =10pf (see note): Figure 4	-	-	1.5	μs
DO Rise Time	t _{dr}	DO, R _{PU} =4.7KΩ, C _L =10pf (see note): Figure 4	-	-	1.5	μs

 Note: Since DO is an open-drain output, these values depend on the resistance of the pull-up resistor R_{PU} and the load capacitance C_L.

9. ELECTRICAL CHARACTERISTICS

Parameter	Symbol	Conditions	Min.	Typ.	Max.	Unit
Hysteresis	V_H	CE, CL, DI, /RES (KI1 to KI5)		0.1V _{DD} (0.1V _{LCD})		V
Power-down Detection Voltage	V_{DET}		1.8	2.2	2.6	V
Input High level Current	I_{IH}	CE, CL, DI, /RES: $V_I=V_{DD}$			5.0	μA
Input Low Level Current	I_{IL}	CE, CL, DI, /RES: $V_I=0V$	-5.0			μA
Input Floating Voltage	V_{IF}	KI1 to KI5			0.05V _{LCD}	V
Pull-down Resistance	R_{PD}	KI1 to KI5: $V_{LCD}=5.0V$	50	100	250	K Ω
Output Off Leakage Current	I_{OFFH}	DO: $V_O=6.0V$			6.0	μA
Output High Level Voltage	V_{OH1}	KS1 to KS6: $I_O=-500\mu A$	$V_{LCD}-1.0$	$V_{LCD}-0.5$	$V_{LCD}-0.2$	V
	V_{OH2}	P1 to P8: $I_O=-1mA$	$V_{LCD}-1.0$			
	V_{OH3}	S1 to S76: $I_O=-20\mu A$	$V_{LCD}-1.0$			
	V_{OH4}	COM1 to COM4: $I_O=-100\mu A$	$V_{LCD}-1.0$			
Output Low Level Voltage	V_{OL1}	KS1 to KS6: $I_O=25\mu A$	0.2	0.5	1.5	V
	V_{OL2}	P1 to P8: $I_O=1mA$			1.0	
	V_{OL3}	S1 to S76: $I_O=20\mu A$			1.0	
	V_{OL4}	COM1 to COM4: $I_O=100\mu A$			1.0	
	V_{OL5}	DO: $I_O=1mA$		0.1	0.5	
Output Middle Level Voltage (see note)	V_{MID1}	COM1 to COM4: 1/2 bias, $I_O=\pm 100\mu A$	$1/2V_{LCD}-1.0$		$1/2V_{LCD}+1.0$	V
	V_{MID2}	S1 to S76: 1/3 bias, $I_O=\pm 20\mu A$	$2/3V_{LCD}-1.0$		$2/3V_{LCD}+1.0$	
	V_{MID3}	S1 to S76: 1/3 bias, $I_O=\pm 20\mu A$	$1/3V_{LCD}-1.0$		$1/3V_{LCD}+1.0$	
	V_{MID4}	COM1 to COM4: 1/3 bias, $I_O=\pm 100\mu A$	$2/3V_{LCD}-1.0$		$2/3V_{LCD}+1.0$	
	V_{MID5}	COM1 to COM4: 1/3 bias, $I_O=\pm 100\mu A$	$1/3V_{LCD}-1.0$		$1/3V_{LCD}+1.0$	
Oscillator Frequency	fosc	OSC: $R_{osc}=39K\Omega$, $C_{osc}=1000pF$	30.4	38	45.6	KHz
Current Drain	I_{DD1}	V_{DD} : Sleep mode			100	μA
	I_{DD2}	V_{DD} : $V_{DD}=6.0V$, output open, fosc=38KHz		270	540	
	I_{LCD1}	V_{LCD} : Sleep mode			5	
	I_{LCD2}	V_{LCD} : $V_{LCD}=6.0V$, output open, 1/2 bias, fosc=38KHz		200	400	
	I_{LCD3}	V_{LCD} : $V_{LCD}=6.0V$, output open, 1/3 bias, fosc=38KHz		120	240	

Note: Excluding the bias voltage generation divider resistor built into VLCD1 and VLCD2. (See Figure 3)

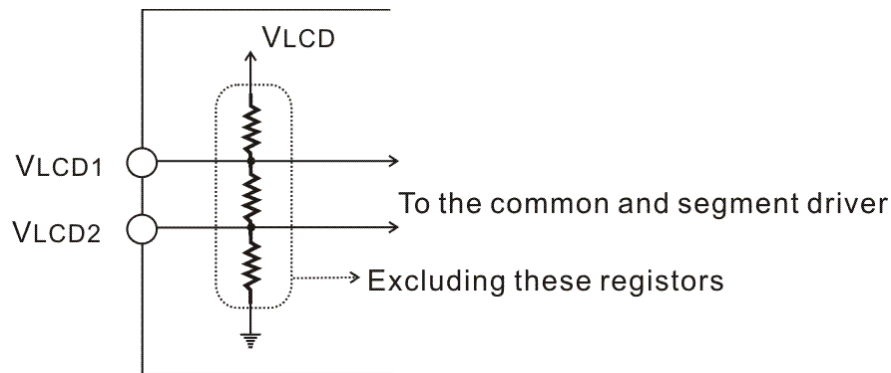
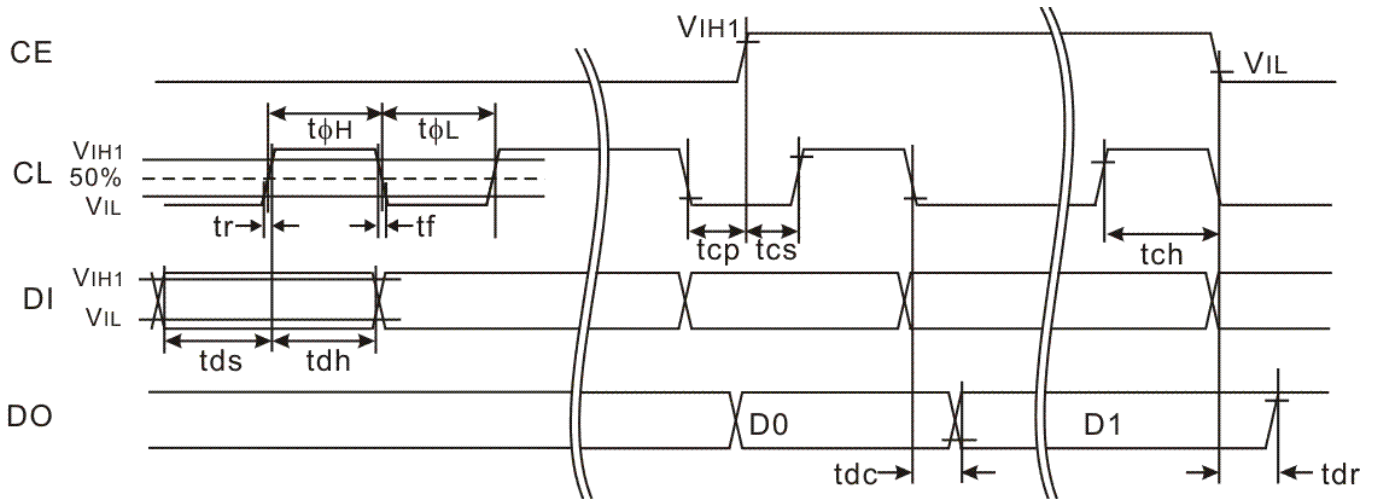

Figure 3

WHEN CL IS STOPPED AT THE LOW LEVEL



WHEN CL IS STOPPED AT THE HIGH LEVEL

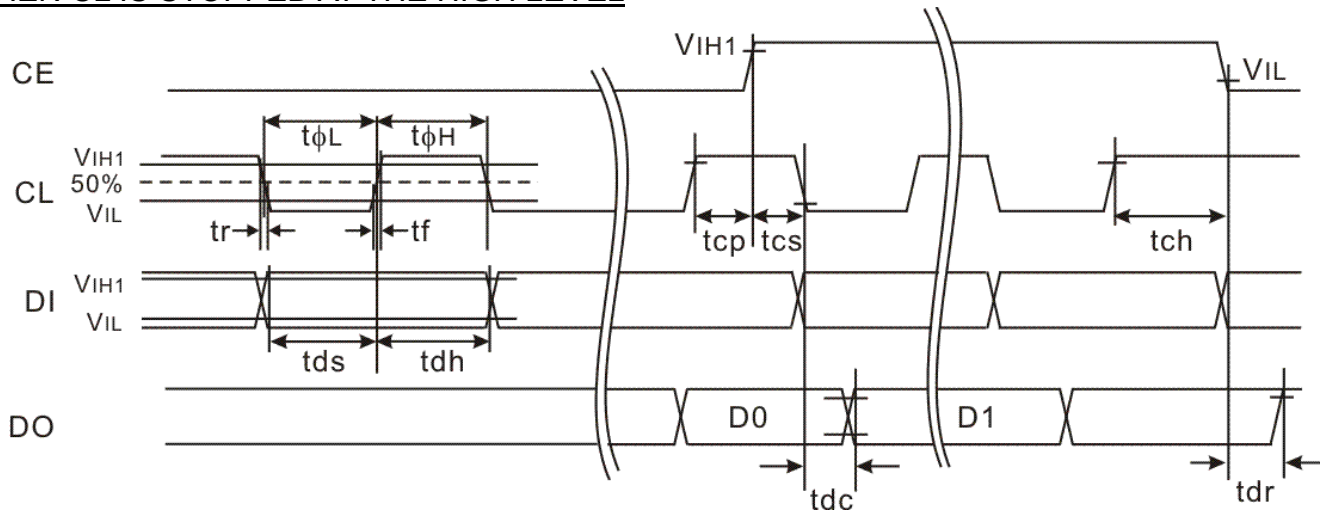
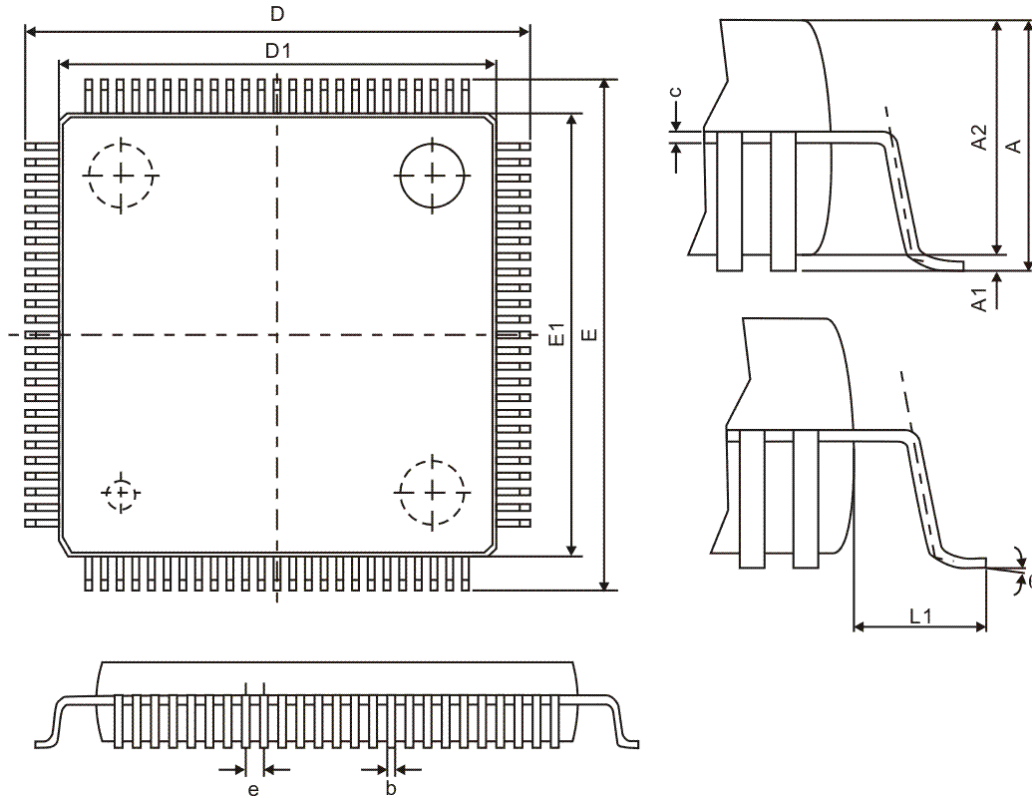

Figure 4

10. PACKAGE INFORMATION

100 PINS, LQFP



Symbol	Min.	Nom.	Max.
A	-	-	1.60
A1	0.05	-	0.15
A2	1.35	1.40	1.45
b	0.17	0.22	0.27
c	0.09	-	0.20
D	16.00 BSC		
D1	14.00 BSC		
E	16.00 BSC		
E1	14.00 BSC		
e	0.50 BSC		
L1	1.00 REF		
θ	0°	3.5°	7°

Notes:

1. All controlling dimensions are in millimeters.
2. Refer to JEDEC MS-026BED

IMPORTANT NOTICE

Princeton Technology Corporation (PTC) reserves the right to make corrections, modifications, enhancements, improvements, and other changes to its products and to discontinue any product without notice at any time.

PTC cannot assume responsibility for use of any circuitry other than circuitry entirely embodied in a PTC product. No circuit patent licenses are implied.

Princeton Technology Corp.
2F, 233-1, Baociao Road,
Sindian, Taipei 23145, Taiwan
Tel: 886-2-66296288
Fax: 886-2-29174598
<http://www.princeton.com.tw>