

DESCRIPTION

The PT6382 is designed to integrate the VFD driver, key-scan matrix, LED driving, infrared (IR) remote control decoding and into one integrated solution. All functions are programmable using 3-wire serial or I²C interface.

In standby operation, the PT6382 provides the standby power management to the chipset for low power consumption

The PT6382 is housed in a 44-pin LQFP package. Pin assignments and application circuit are optimized for easy PCB layout and cost saving advantages.

APPLICATIONS

- VCR
- DVD recorder
- Home theater
- Set-top box and other application that require a compact, integrated solution
- HTiB (Home theater in a Box)
- Personal Video recorders (PVRs)

FEATURES

- IC front panel VFD controller driver
- Standby power management to the host
- 3.3V (VDD) and down to -30V (VEE) supply for the IC
- IR remote control decoder (Philips, NEC, Thomson, Sony, Matsushita)
- Multiple display modes (12 segments and 12 digits to 20 segments and 4 digits)
- High voltage outputs (VDD - 33.3V max)
- No external resistors necessary for driver outputs (P-CH. Open drain + pull-down resistor)
- Key scanning (up to 12 x 2 matrix = 24 keys)
- LED ports (IOL=20mA@1V, IOH=1mA@0.9VDD)
- 3-wire (SPI) serial interface for clock, data input/output, and strobe
- I²C serial interface (SCL, SDA) communication protocol
- Programmable hotkeys for IR remote control command
- Programmable hotkeys for KEYSKAN command
- Low power consumption in standby mode
- Dimming circuit (8 steps)
- Available in LQFP-44 package

BLOCK DIAGRAM

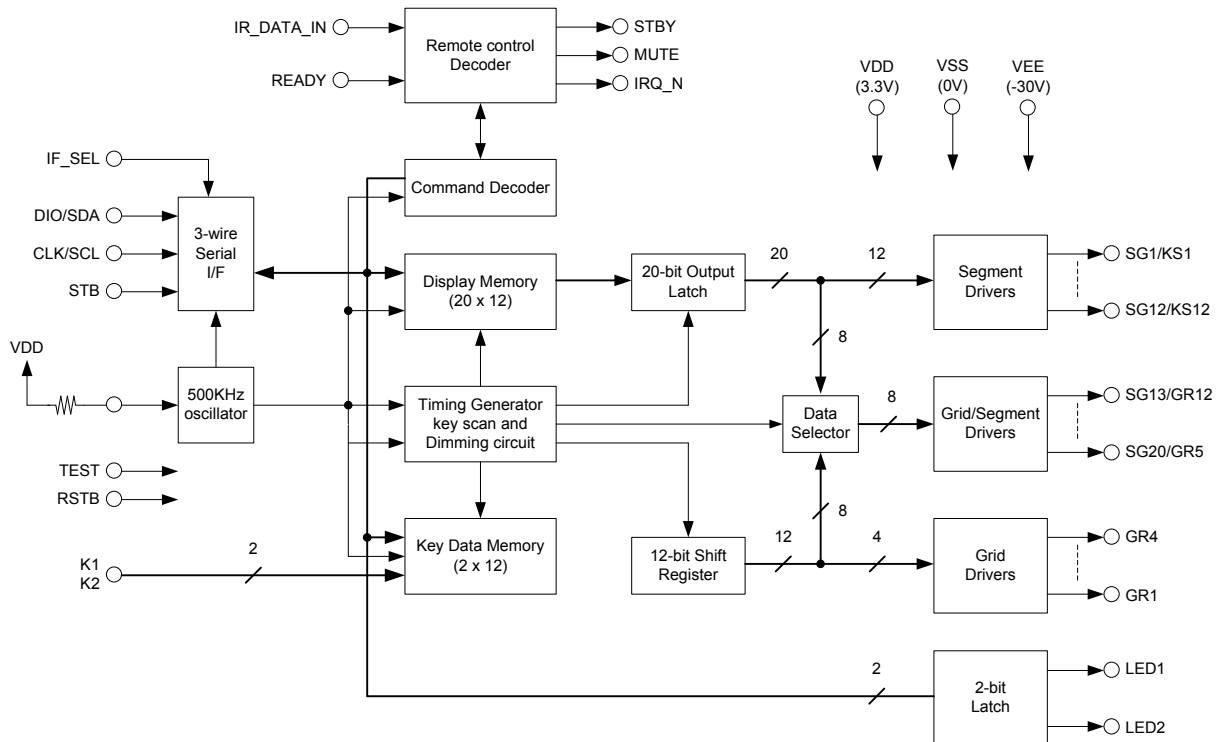

1. TYPICAL APPLICATION CIRCUIT

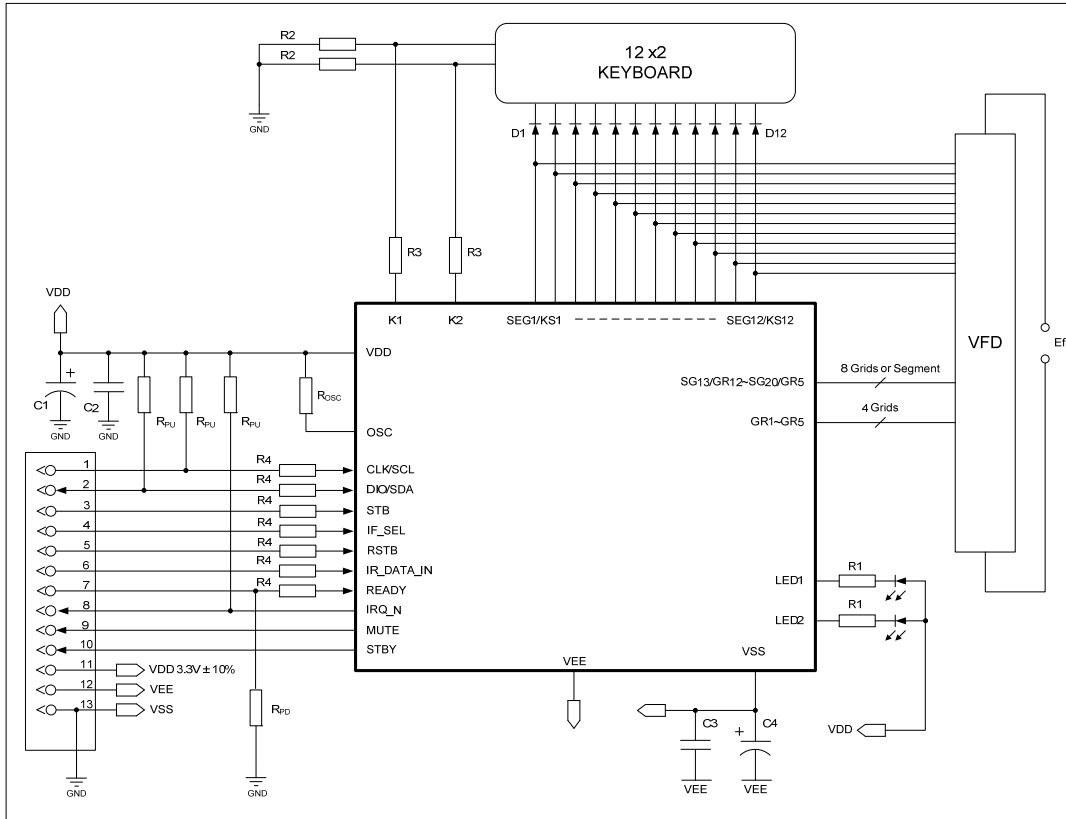

- R1 = 0.75 ~ 1.2kΩ
- R2 = 10kΩ for external keyboard pull-down resistor
- R3 = 0.1k ~ 1kΩ
- R4 = 0.1k ~ 1kΩ
- R_{pu} = 4.7kΩ for external pull-up resistor on DIO/SDA, CLK/SCL
- R_{pu} = 10kΩ for external pull-up resistor on IRQ_N
- R_{pd} = 10kΩ for external pull-down resistor on READY
- R_{osc} = 33kΩ (±1%) for oscillator resistor
- C1 = 33μF-25V electrolytic capacitor
- C2 = 0.01~ 0.1μF-25V ceramic capacitor
- C3 = 0.01~ 0.1μF-63V ceramic capacitor
- C4 = 33μF-63V electrolytic capacitor
- D1 ~ D12 = 1N4148
- Ef = filament voltage according to the VFD specs
- VDD = 3.3V ± 10%
- VEE = down to VDD - 33.3V

2. FUNCTION DIAGRAM

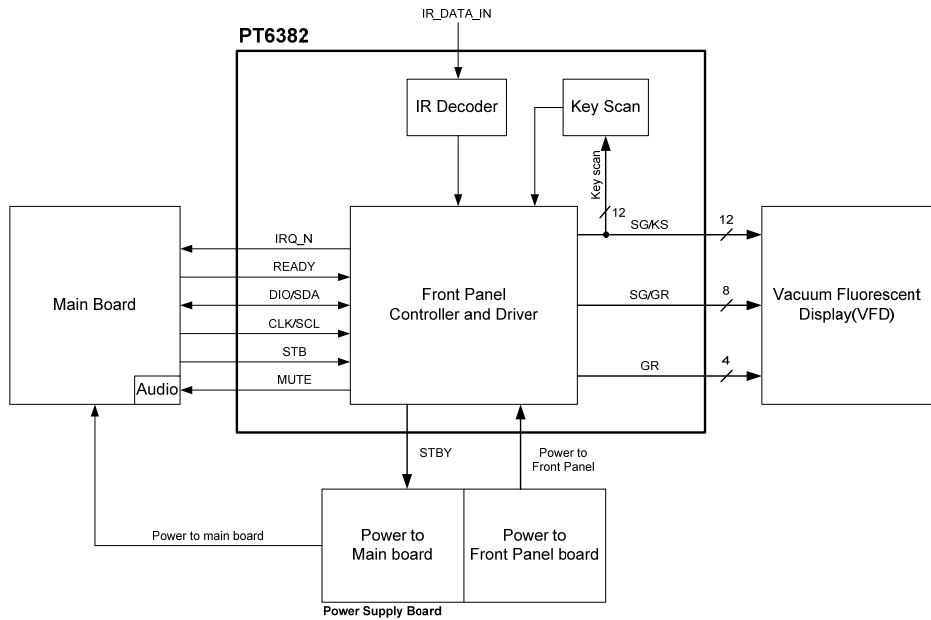

3. ORDER INFORMATION

Valid Part Number	Package Type	Top Code
PT6382-LQ	44 Pins, LQFP	PT6382-LQ

4. PIN CONFIGURATION

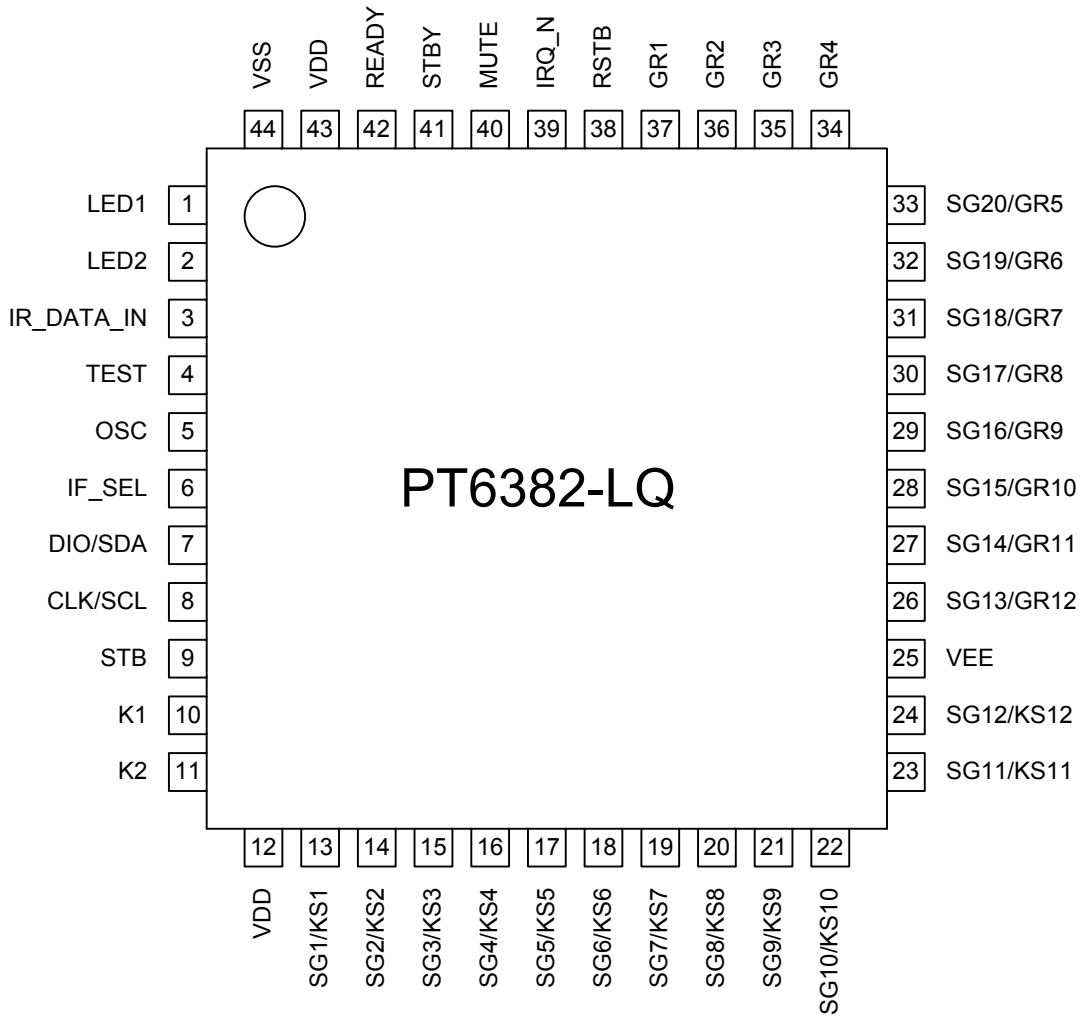

5. PIN DESCRIPTION

Pin Name	I/O	Description	Pin No
LED1, LED2	O	CMOS Sink outputs (20 mA max.)	1, 2
IR_DATA_IN	I	Remote control input. Connect to IR photodiode	3
TEST	O	TEST pin with an internal pull-down resistor. Customer can't use this pin	4
OSC	I	Connect to an external resistor of value $33K\Omega \pm 1\%$	5
IF_SEL	I	Serial interface mode setting IF_SEL = "0" → I ² C interface, IF_SEL = "1" → 3-wire (SPI) interface	6
DIO/SDA	I/O	IF_SEL = "0" → The data pin of I ² C interface. Connect to 3.3V through an external pull-up resistor. IF_SEL = "1" → The data pin of 3-wire interface. Connect to 3.3V through an external pull-up resistor. Serial data must be ready at the rising edge of CLK. This pin outputs data at the falling edge of CLK	7
CLK/SCL	I	IF_SEL = "0" → The clock pin of I ² C interface. Connect to 3.3V through an external pull-up resistor IF_SEL = "1" → The clock pin of 3-wire interface. Serial data is read at rising edge and output data is valid at the falling edge	8
STB	I	IF_SEL = "0" → Unused pin IF_SEL = "1" → The strobe pin of 3-wire interface	9
K1, K2	I	Input data to these pins from external keyboard are latched at the end of the display cycle (maximum keyboard size is 12 x 2)	10, 11
VDD	-	3.3V±10% positive power supply	12, 43
SG1/KS1 to SG12/KS12	O	Segment output pins(dual function as key source)	13~24
VEE	-	VFD outputs high voltage pull_down level. VDD-33.3V max.	25
SG13/GR12 to SG20/GR5	O	These pins are selectable for segment or grid driving	26~33
GR4 to GR1	O	Grid output pins	34~37
RSTB	I	Active low reset input pin	38
IRQ_N	O	Interrupt (Open Drain). A pull up resistor of 10KΩ must be connected on this pin	39
MUTE	O	High level means mute status for audio. Low level stands for normal working	40
STBY	O	Pin to control power to the main board. High level means stand-by status. Low level stands for normal working	41
READY	I	High level on this pin means that main board chip has been working normally. Connect an external pull down resistor of 10kΩ on this pin	42
VSS	-	Connect this pin to system GND	44

IMPORTANT NOTICE

Princeton Technology Corporation (PTC) reserves the right to make corrections, modifications, enhancements, improvements, and other changes to its products and to discontinue any product without notice at any time.

PTC cannot assume responsibility for use of any circuitry other than circuitry entirely embodied in a PTC product. No circuit patent licenses are implied.

Princeton Technology Corp.
2F, 233-1, Baociao Road,
Sindian, Taipei 23145, Taiwan
Tel: 886-2-66296288
Fax: 886-2-29174598
<http://www.princeton.com.tw>