

Princeton Technology Corp. reserves the right to change the product described in this datasheet. All information contained in this datasheet is subject to change without prior notice. Princeton Technology Corp. assumes no responsibility for the use of any circuits shown in this datasheet.

Description

The PA2464 is a Power Amplifier (PA) IC as the final RF amplifier for handheld applications in the 400MHz to 480MHz band.

Features

- ◆ Single 3.5V to 6V Supply Voltage
- ◆ +36dBm Output Power
- ◆ 75% Efficiency
- ◆ 8-pin SOP(FD) package (5mm x 4mm)

Applications

- ◆ FRS, GMRS Handsets
- ◆ Commercial and Consumer Systems
- ◆ Portable Battery-Powered Equipment
- ◆ Long distance Remote Control

Block Diagram

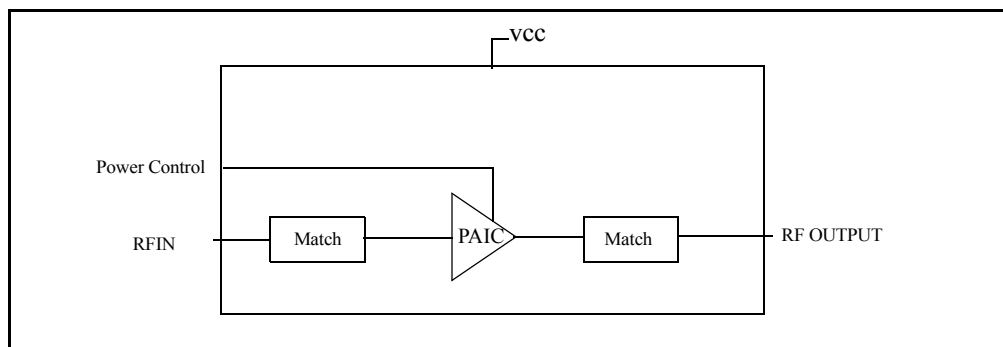

Package and Pin Assignment: 8-Pin SOP(FD)

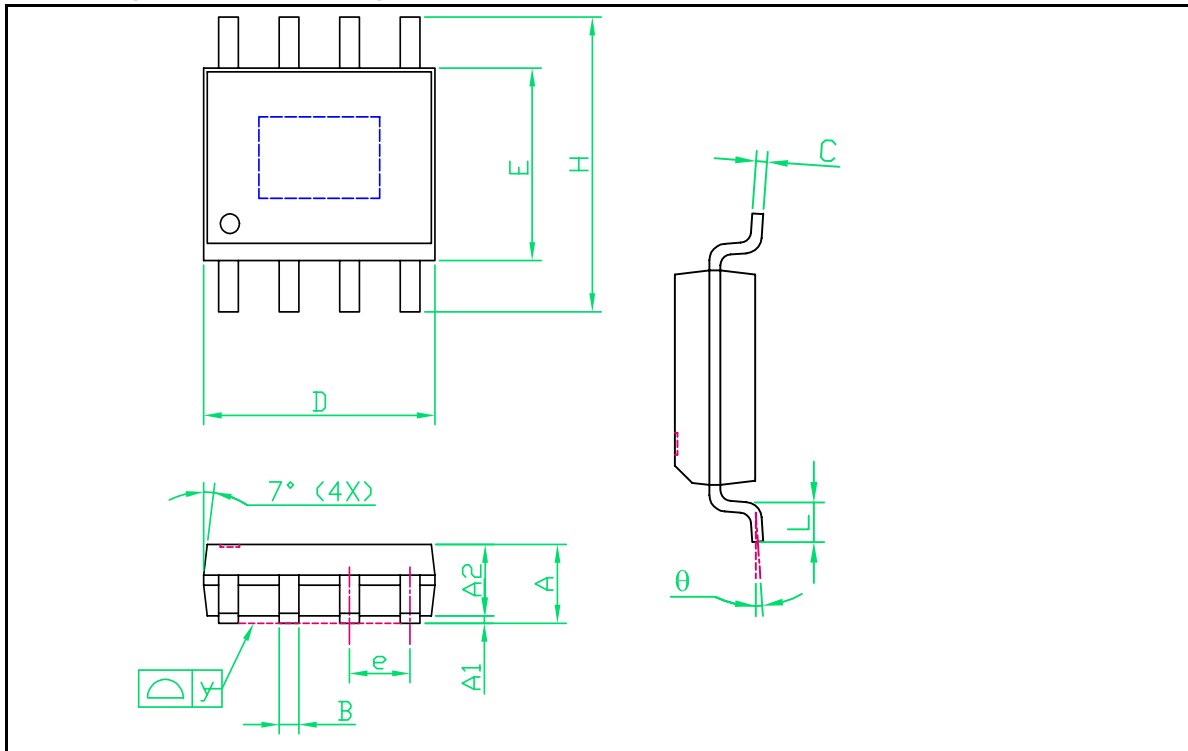

Symbols	Dimensions in mm			Dimensions in inch		
	min.	nom.	max.	min.	nom.	max.
A	1.45	1.50	1.55	0.057	0.059	0.061
A1	0.00	---	0.10	0.000	---	0.004
A2	---	1.45	---	---	0.057	---
B	0.33	---	0.51	0.013	---	0.020
C	0.19	---	0.25	0.007	---	0.010
D	4.80	---	5.00	0.189	---	0.197
E	3.80	---	4.00	0.150	---	0.157
e	---	1.27	---	---	0.050	---
H	5.80	---	6.20	0.228	---	0.244
L	0.40	---	1.27	0.016	---	0.050
y	---	---	0.10	---	---	0.004
theta	0°	---	8°	0°	---	8°

Pin Descriptions

Number	Name	I/O	Description
1	APC1	I	Analog Power Control
2	NC	I	No Connection
3	RF_IN	I	RF Input
4	VCC	Power	Power supply for PA
5	L2	I	Connect to PIN4 through a matching section,do not short to GND or PIN4.
6	RF_OUT	O	RF Output
7	RF_OUT	O	RF Output
8	APC2	I	Analog Power Control

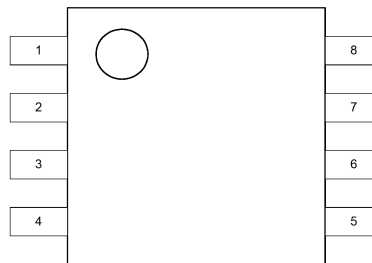

Absolute Maximum Ratings

$$V_{SS} = V_{SS1} = 0 \text{ V}$$

Parameter	Symbol	Rating	Unit
Supply Voltage	V_{CC}	6	V
Supply current	I_{CC}	1000	mA
Input Power	P_{IN}	10	dBm
Operating Temperature Range	T_{OPR}	5 to 100	°C
Storage Temperature Range	T_{STG}	-40 to 125	°C
Soldering Temperature Range	T_{SLD}	255	°C
Soldering Time Range	t_{SLD}	10	s

Recommended Operating Conditions

$$V_{SS} = V_{SS1} = 0 \text{ V}$$

Parameter	Symbol	Value			Unit
		min.	typ.	max.	
Supply Voltage Range	V_{CC}		3.5	6	V
Operating Temperature	T_A	-30	25	85	°C

Electrical Characteristics

($V_{CC} = 6V$, $V_{SS} = 0V$, $T_A = 25^{\circ}C$, $R_L = 50 \text{ Ohm}$)

Parameter	Symbol	Condition	Value			Unit
			min.	typ.	max.	
VCC Supply Voltage	V_{CC}			6		V
Frequency Range	f		400		480	MHz
Input Power	P_{IN}		-	5	-	dBm
Output Power	P_{OUT}	$P_{IN} = 5\text{dBm}$	-	36		dBm
Efficiency		$P_{IN} = 5\text{dBm}$		75		%
Current Consumption	I	$P_{OUT} = 36\text{dBm}, V_{CC} = 6V$		900	1000	mA
Control Voltage Range	V_{APC}		0.2		1.6	V
Full Power Control Voltage		$P_{OUT} = 36\text{dBm}$		1.5		V
Control Current into V_{APC}	I_{APC}			40		mA
2nd to 13th Harmonic Distortion		$P_{OUT} = 36\text{dBm}$		-20		dBc
Input VSWR		All power level		1.5:1	2:1	
Rise Time and Fall Time		$P_{OUT} = 36\text{dBm}$			2	μsec

Electrical Characteristics

($V_{CC} = 4.5V$, $V_{SS} = 0V$, $T_A = 25^\circ C$, $R_L = 50 \text{ Ohm}$)

Parameter	Symbol	Condition	Value			Unit
			min.	typ.	max.	
VCC Supply Voltage	V_{CC}			4.5		V
Frequency Range	f		400		480	MHz
Input Power	P_{IN}		-	5	-	dBm
Output Power	P_{OUT}	$P_{IN} = 5\text{dBm}$	-	35		dBm
Efficiency		$P_{IN} = 5\text{dBm}$		65		%
Current Consumption	I	$P_{OUT} = 35\text{dBm}, V_{CC} = 4.5V$		1070	1200	mA
Control Voltage Range	V_{APC}		0.2		1.4	V
Full Power Control Voltage		$P_{OUT} = 35\text{dBm}$		1.3		V
Control Current into V_{APC}	I_{APC}			40		mA
2nd to 13th Harmonic Distortion		$P_{OUT} = 35\text{dBm}$		-20		dBc
Input VSWR		All power level		1.5:1	2:1	
Rise Time and Fall Time		$P_{OUT} = 35\text{dBm}$			2	μsec

Electrical Characteristics

($V_{CC} = 3.5V$, $V_{SS} = 0V$, $T_A = 25^\circ C$, $R_L = 50 \text{ Ohm}$)

Parameter	Symbol	Condition	Value			Unit
			min.	typ.	max.	
VCC Supply Voltage	V_{CC}			3.5		V
Frequency Range	f		400		480	MHz
Input Power	P_{IN}		-	5	-	dBm
Output Power	P_{OUT}	$P_{IN} = 5\text{dBm}$	-	34		dBm
Efficiency		$P_{IN} = 5\text{dBm}$		60		%
Current Consumption	I	$P_{OUT} = 34\text{dBm}, V_{CC} = 3.5V$		1180	1300	mA
Control Voltage Range	V_{APC}		0.2		1.5	V
Full Power Control Voltage		$P_{OUT} = 34\text{dBm}$		1.4		V
Control Current into V_{APC}	I_{APC}			40		mA
2nd to 13th Harmonic Distortion		$P_{OUT} = 34\text{dBm}$		-20		dBc
Input VSWR		All power level		1.5:1	2:1	
Rise Time and Fall Time		$P_{OUT} = 34\text{dBm}$			2	μsec

Electrical Characteristics

($V_{CC} = 3.0V$, $V_{SS} = 0V$, $T_A = 25^\circ C$, $R_L = 50 \text{ Ohm}$)

Parameter	Symbol	Condition	Value			Unit
			min.	typ.	max.	
VCC Supply Voltage	V_{CC}			3		V
Frequency Range	f		400		480	MHz
Input Power	P_{IN}		-	5	-	dBm
Output Power	P_{OUT}	$P_{IN} = 5\text{dBm}$	-	33		dBm
Efficiency		$P_{IN} = 5\text{dBm}$		55		%
Current Consumption	I	$P_{OUT} = 33\text{dBm}, V_{CC} = 3V$		1190	1300	mA
Control Voltage Range	V_{APC}		0.2		1.5	V
Full Power Control Voltage		$P_{OUT} = 33\text{dBm}$		1.4		V
Control Current into V_{APC}	I_{APC}			40		mA
2nd to 13th Harmonic Distortion		$P_{OUT} = 33\text{dBm}$		-20		dBc
Input VSWR		All power level		1.5:1	2:1	
Rise Time and Fall Time		$P_{OUT} = 33\text{dBm}$			2	μsec

Evaluation Board Circuit

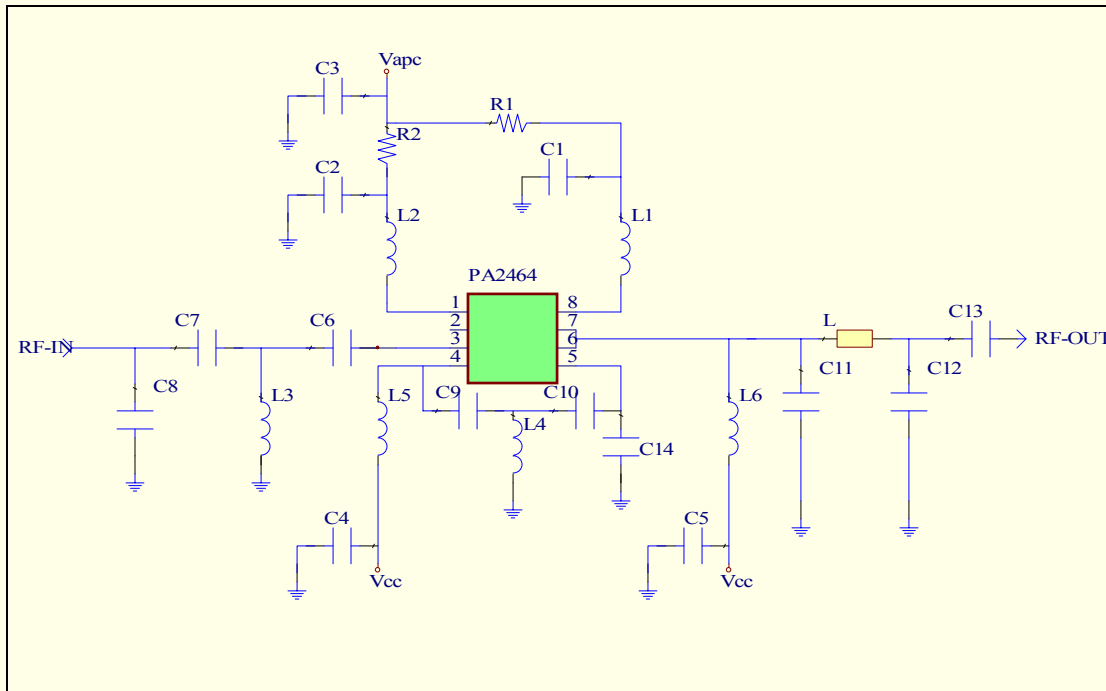

Evaluation Board Layout

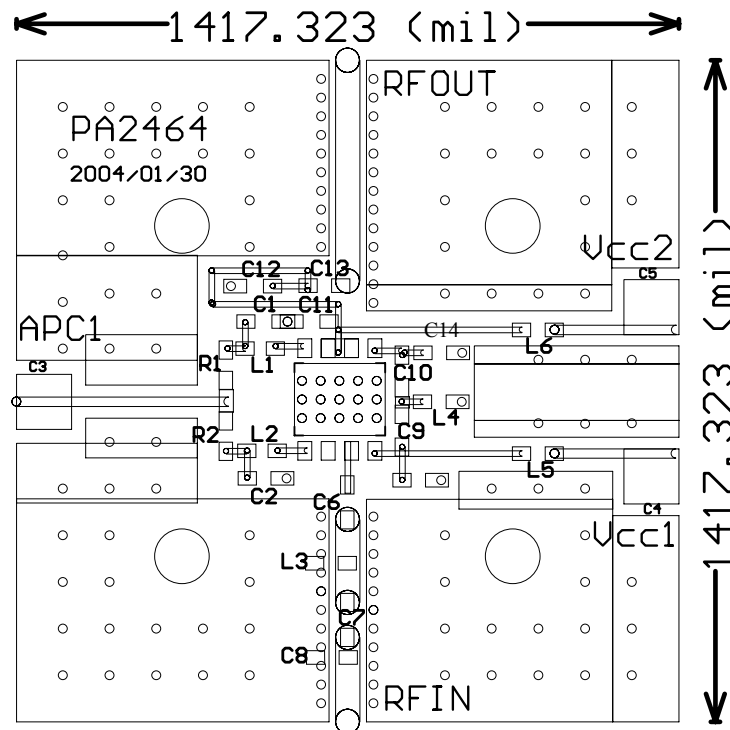

BOM

VCC	3V	3.5V	4.5V	6V	6V	6V
Freq.(MHz)	465	465	465	465	465	465
Pout	33dBm	34dBm	35dBm	36dBm	3W	2W
EFF(%)	55	60	65	75	65	55
Vapc	1.42V	1.39V	1.28V	1.5V	1.36V	1.09V
C1/C2	1nF	1nF	1nF	1nF	1nF	1nF
C3/C4/C5	1uF	1uF	1uF	1uF	1uF	1uF
C6	100pF	100pF	100pF	100pF	100pF	100pF
C7	6pF	6pF	6pF	6pF	7pF	4.7pF
C8	6pF	6pF	6pF	18pF	12pF	10pF
C9	18pF	18pF	18pF	100pF	100pF	100pF
C10	100pF	100pF	100pF	11pF	7pF	7pF
C11	6pF	6pF	6pF	5pF	5pF	5pF
C12	7pF	7pF	7pF	8pF	7pF	7pF
C13	4pF	5pF	6pF	15pF	15pF	15pF
C14	6pF	6pF	6pF	-	-	-
L1/L2	100nH	100nH	100nH	100nH	100nH	100nH
L3	15nH	15nH	15nH	15nH	12nH	15nH
L4	-	-	-	10nH	22nH	22nH
*L5/L6	25nH	25nH	25nH	25nH	25nH	25nH
R1/R2	0 ohm	0 ohm	0 ohm	0 ohm	0 ohm	0 ohm

* air coil inductor

Typical Characteristics

465MHz, Vcc=6V, Pin=5dBm, Vapc=1.5V

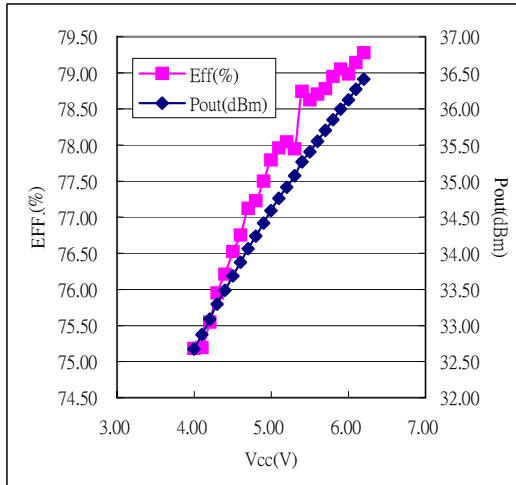

Fig 1.1 Output Power vs. Vcc

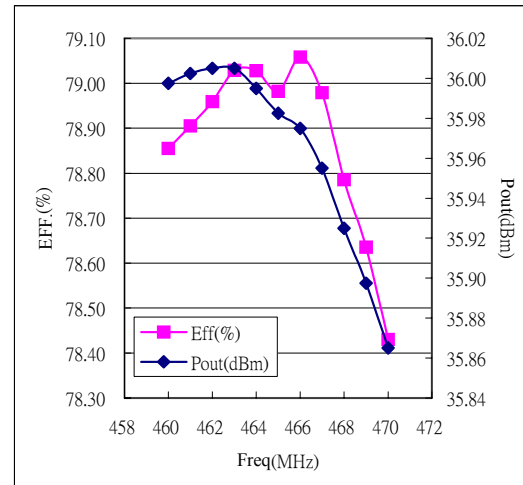

Fig 1.2 Output Power vs. Frequency

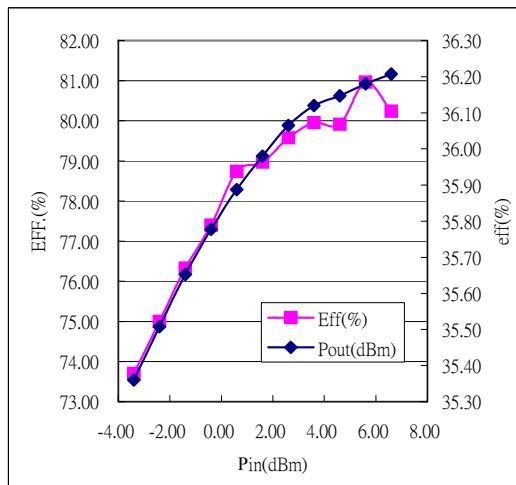

Fig 1.3 Output Power vs. Input Power

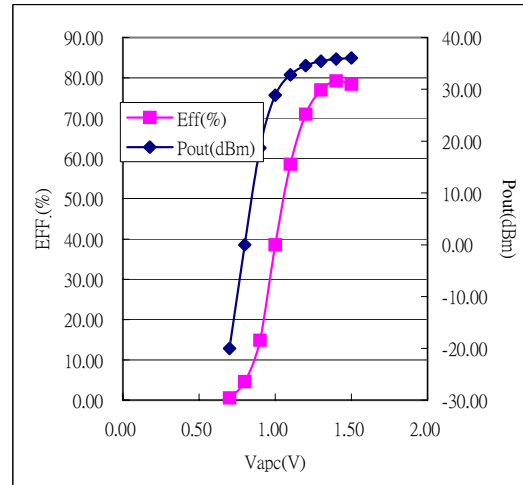

Fig 1.4 Output Power vs. Control Voltage

Typical Characteristics

465MHz, $V_{cc}=4.5V$, $P_{in}=5dBm$, $V_{apc}=1.28V$

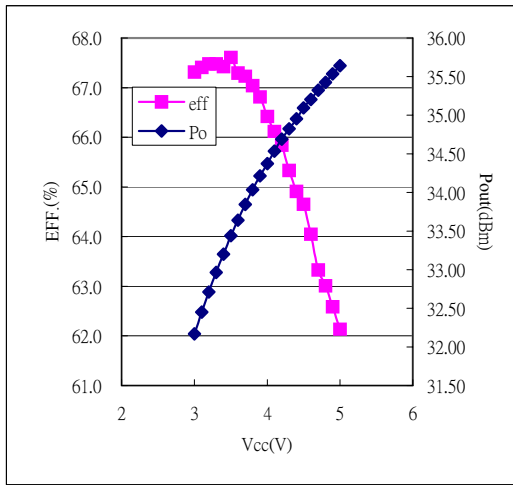

Fig 2.1 Output Power vs. Vcc

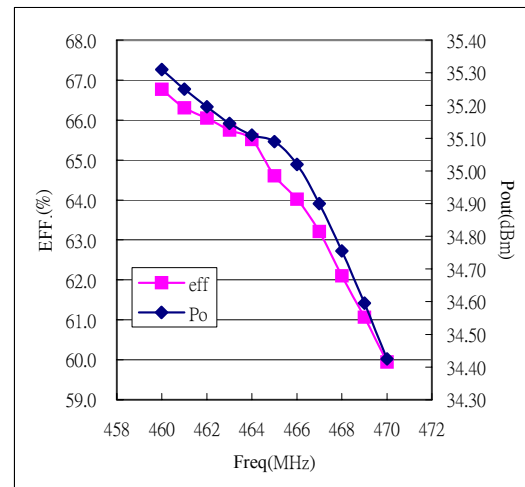

Fig 2.2 Output Power vs. Frequency

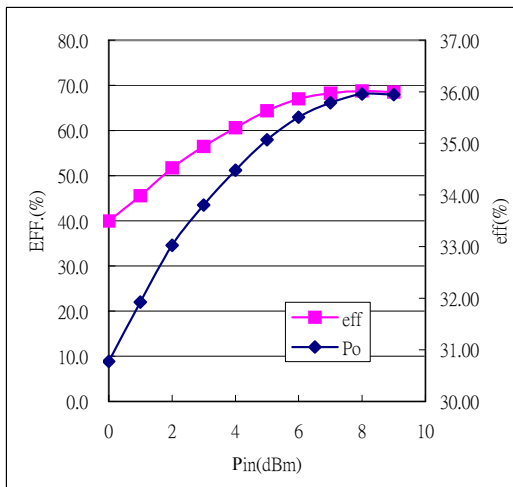

Fig 2.3 Output Power vs. Input Power

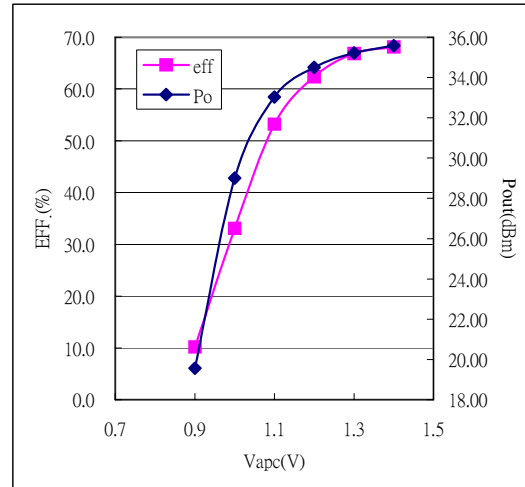

Fig 2.4 Output Power vs. Control Voltage

Typical Characteristics

465MHz, $V_{cc}=3.5V$, $P_{in}=5dBm$, $V_{apc}=1.39V$

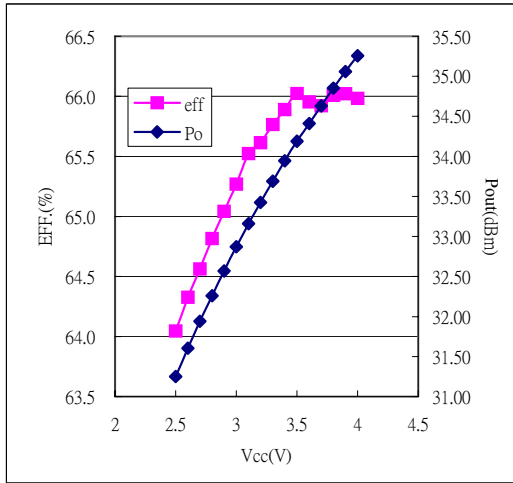

Fig 3.1 Output Power vs. Vcc

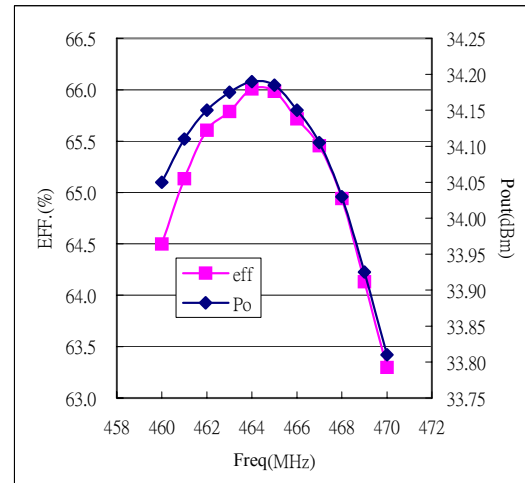

Fig 3.2 Output Power vs. Frequency

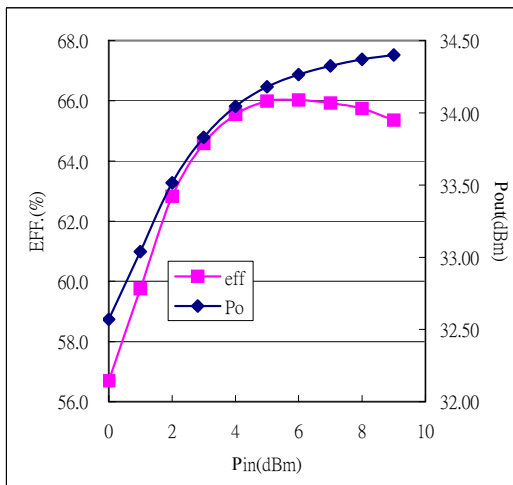

Fig 3.3 Output Power vs. Input Power

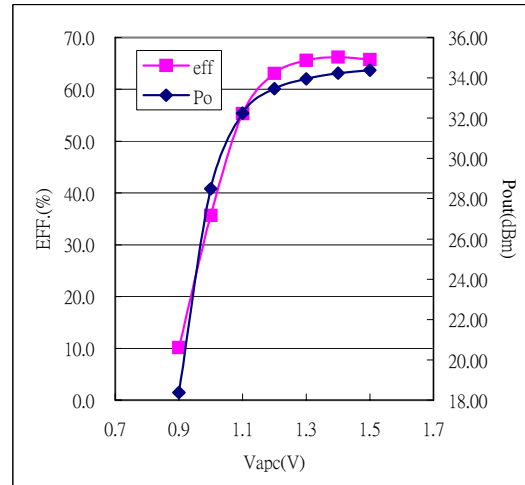

Fig 3.4 Output Power vs. Control Voltage

Typical Characteristics

465MHz, $V_{cc}=3V$, $P_{in}=5dBm$, $V_{apc}=1.42V$

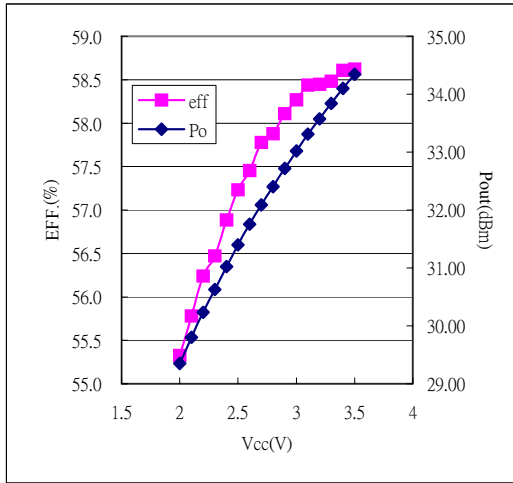

Fig 4.1 Output Power vs. Vcc

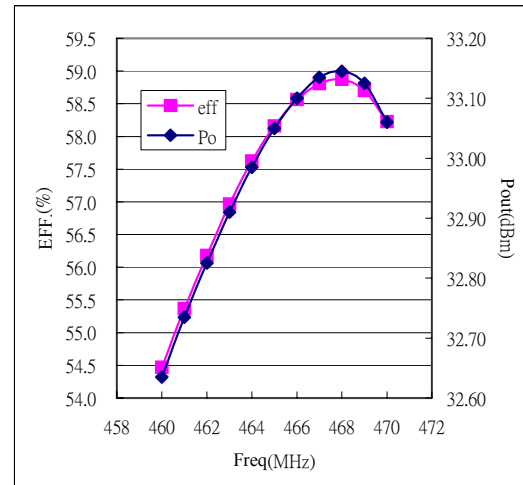

Fig 4.2 Output Power vs. Frequency

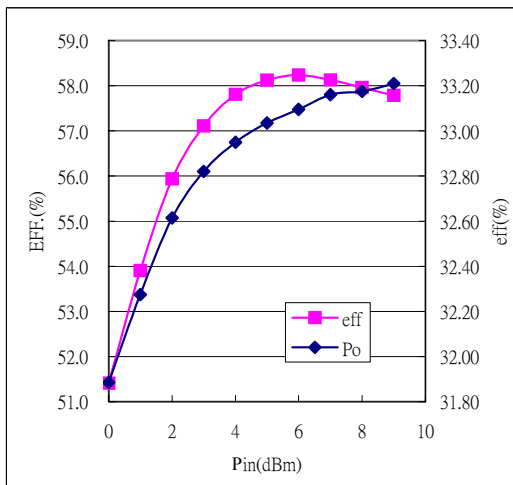

Fig 4.3 Output Power vs. Input Power

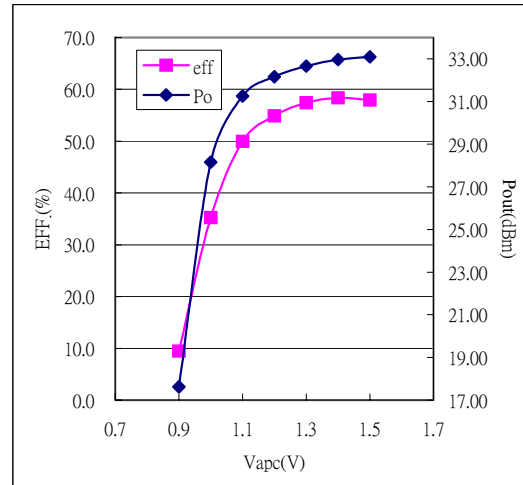
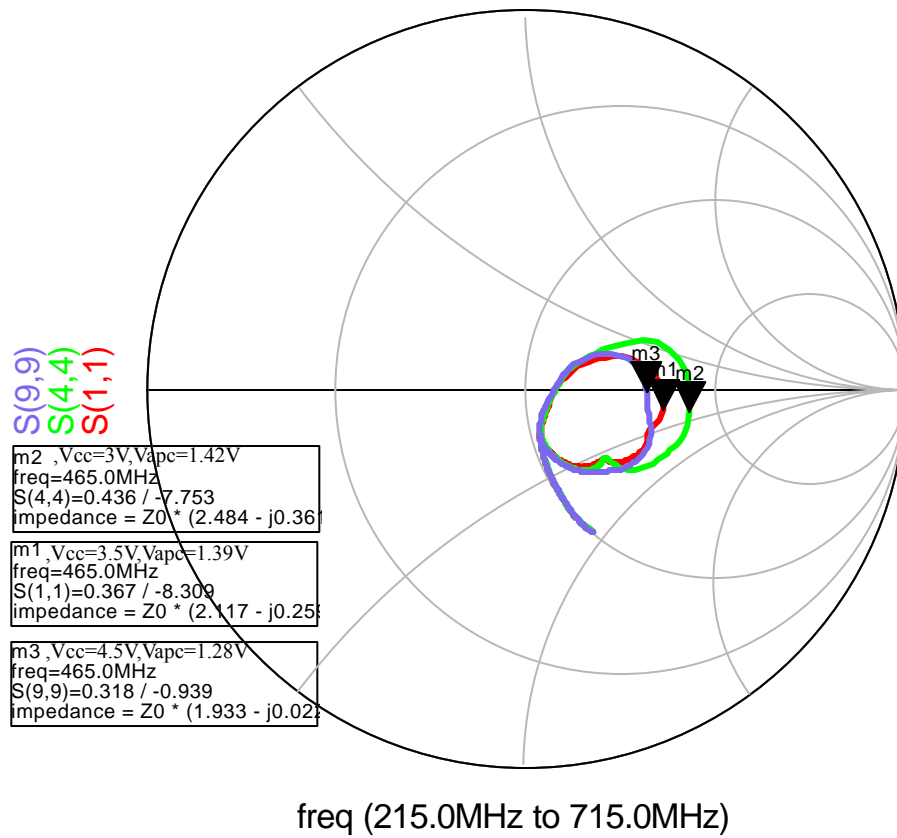

Fig4.4 Output Power vs. Control Voltage

Input Impedance

465MHz, Pin=5dBm



NOTE:1. C7=C6=100pF,C8=X,L3=X

2. Z0=50 ohm