

DESCRIPTION

PT4452 is a high performance OOK/ASK/FSK transmitter for the Remote Keyless Entry (RKE) systems. It consists of a power amplifier, one-shot circuit and phase-locked loop with internal voltage controlled oscillator and loop filter. The one-shot circuit controls the phase-locked loop and power amplifier to have fast start-up time in operation.

APPLICATIONS

- Keyless entry systems
- Remote control systems
- Garage door openers
- Alarm systems
- Security systems
- Wireless sensors

FEATURES

- Highly integrated OOK/ASK/FSK transmitter
- High output power, 3V/+11dBm/17mA
- Low supply voltage, 2.4V to 3.6V operation range
- Low external component cost.
- PLL-based transmitter with frequency range from 300MHz to 450MHz
- On-chip one-shot circuit
- 60 dB RF on-off ratio for OOK/ASK modulation
- SOP8 package

BLOCK DIAGRAM

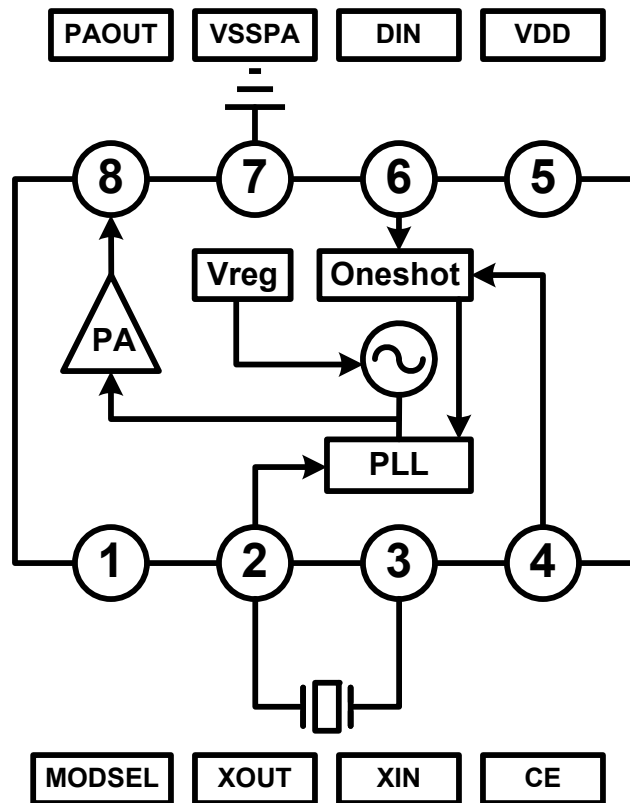

APPLICATION CIRCUIT

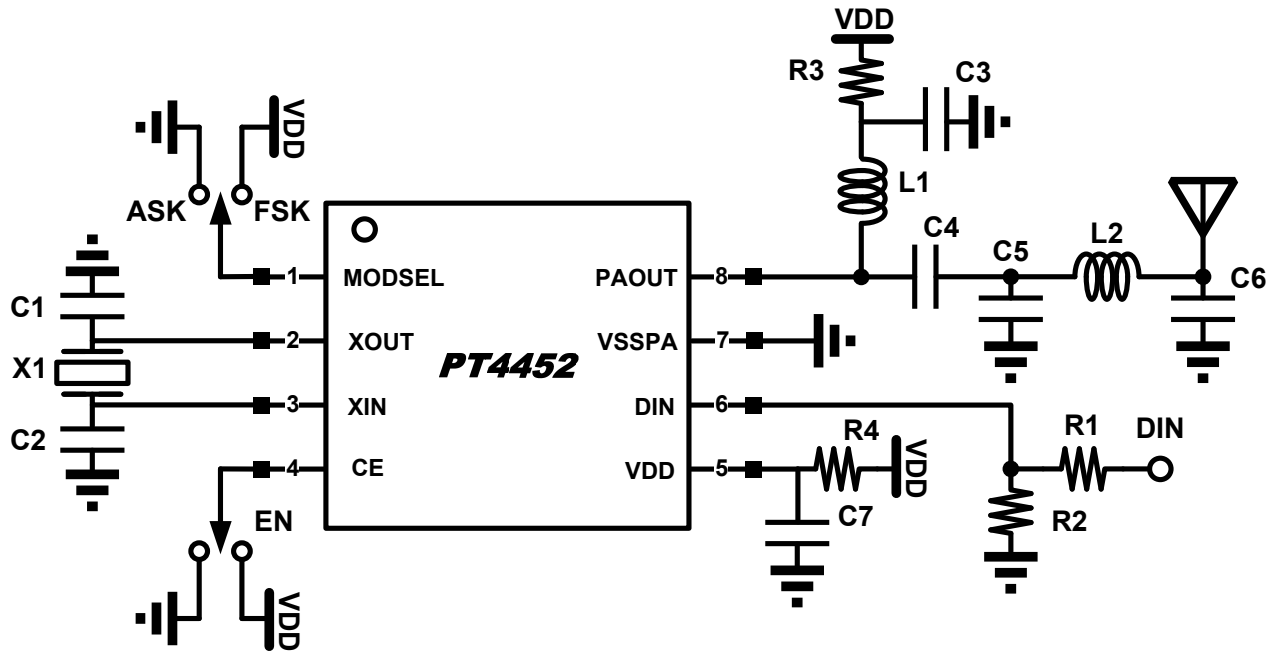

BILL OF MATERIALS

Part	Value		Unit
	315MHz	433.92MHz	
X1	9.844M	13.56M	Hz
R1	10K	10K	Ohm
R2	100K	100K	Ohm
R3	0	0	Ohm
R4	0	0	Ohm
C1	22p	18p	F
C2	22p	18p	F
C3	1 μ	1u	F
C4	220p	220p	F
C5	8.2p	4.7p	F
C6	18p	10p	F
C7	2.2 μ	2.2 μ	F
L1	180n	180n	H
L2	33n	27n	H

Notes:

1. C1/C2 can be used to trim the transmitted signal frequency for matching the specified value.
2. For FSK application to have adequate frequency deviation, and accurate carrier frequency, the crystal resonator frequency will be lower than the specified value. The recommended crystal resonator frequency is 9.8388MHz and 13.5545MHz for 315MHz and 433.92MHz band. The loading capacitor C1/C2 will put below 20pF to have ± 50 KHz pulling frequency deviation at least.
3. L2/C5/C6 value will depend on PCB layout.
4. The recommend maximum ESR value of X1 is 40 Ω .

ORDER INFORMATION

Valid Part Number	Package Type	Top Code
PT4452-S	8-Pin, SOP, 150MIL	PT4452-S

PIN CONFIGURATION

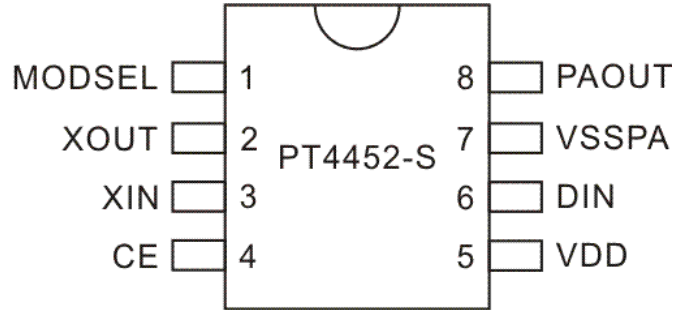

PIN DESCRIPTION

Pin Name	I/O	Description	Pin No.
MODSEL	I	ASK/FSK modulation selection. "0"=ASK, "1"=FSK	1
XOUT	O	Oscillator output	2
XIN	I	Oscillator input	3
CE	I	Chip enables. "1" to enable the chip	4
VDD	P	Power supply	5
DIN	I	Data input	6
VSSPA	G	Power amplifier ground	7
PAOUT	O	Power amplifier output	8

IMPORTANT NOTICE

Princeton Technology Corporation (PTC) reserves the right to make corrections, modifications, enhancements, improvements, and other changes to its products and to discontinue any product without notice at any time.

PTC cannot assume responsibility for use of any circuitry other than circuitry entirely embodied in a PTC product. No circuit patent licenses are implied.

Princeton Technology Corp.
2F, 233-1, Baociao Road,
Sindian Dist., New Taipei City 23145, Taiwan
Tel: 886-2-66296288
Fax: 886-2-29174598
<http://www.princeton.com.tw>