

## DESCRIPTION

RS2123 is a high performance offline PSR controller for low power AC/DC charger and adapter applications. It operates in primary-side sensing and regulation. Consequently, opto-coupler and TL431 could be eliminated. Proprietary Constant Voltage (CV) and Constant Current (CC) control is integrated as shown in the figure below. In CC control, the current and output power setting can be adjusted externally by the sense resistor  $R_s$  at CS pin. In CV control, PFM operations are utilized to achieve high performance and high efficiency. In addition, good load regulation is achieved by the built-in cable drop compensation.

The chip consumes very low operation current (typical  $350\mu\text{A}$ ), it can achieve less than  $30\text{mW}$  standby power to meet strict standby power standard.

RS2123 offers comprehensive protection coverage with auto-recovery features including Cycle-by-Cycle current limiting, VDD over voltage protection, feedback loop open protection, short circuit protection, built-in leading edge blanking, VDD under voltage lockout (UVLO), etc.

## FEATURES

- $\pm 5\%$  constant voltage regulation at universal AC input
- High precision Constant Current Regulation at Universal AC input
- Primary-side Sensing and Regulation without TL431 and Opto-coupler
- Programmable CV and CC Regulation
- Built-in Primary winding inductance compensation
- Programmable Cable Drop Compensation
- Built-in 700V Power BJT
- Ultra Low Start-up Current (Typ.  $1\mu\text{A}$ )
- VDD Over Voltage Protection
- Built-in Feedback Loop Open Protection
- Built-in Short Circuit Protection
- Built-in Leading Edge Blanking (LEB)
- Cycle-by-Cycle Current Limiting
- VDD Under Voltage Lockout with Hysteresis (UVLO)
- DIP-8 green Packaging

## APPLICATIONS

Low Power AC/DC offline SMPS for

- Cell phone charger
- Digital cameras charger
- Small power adaptor
- Auxiliary power for PC, TV etc.
- Linear regulator/RCC replacement

## TYPICAL CC/CV CURVE

Output Voltage

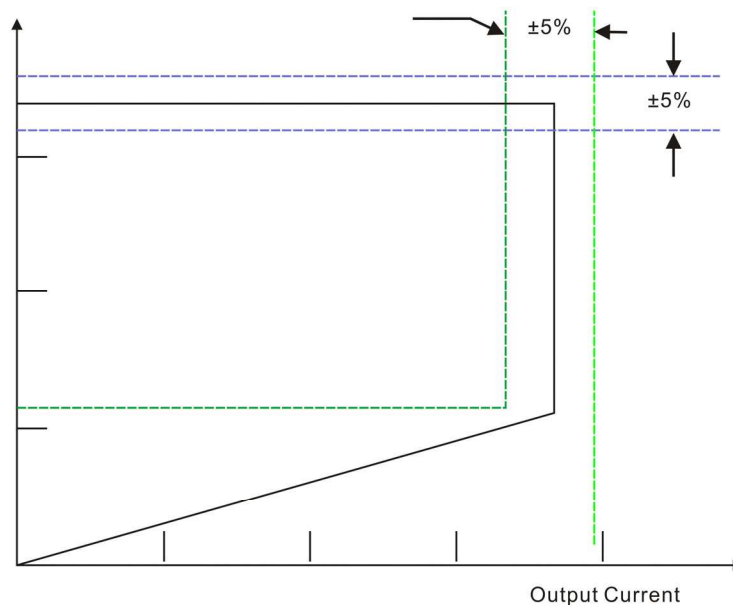

# BLOCK DIAGRAM

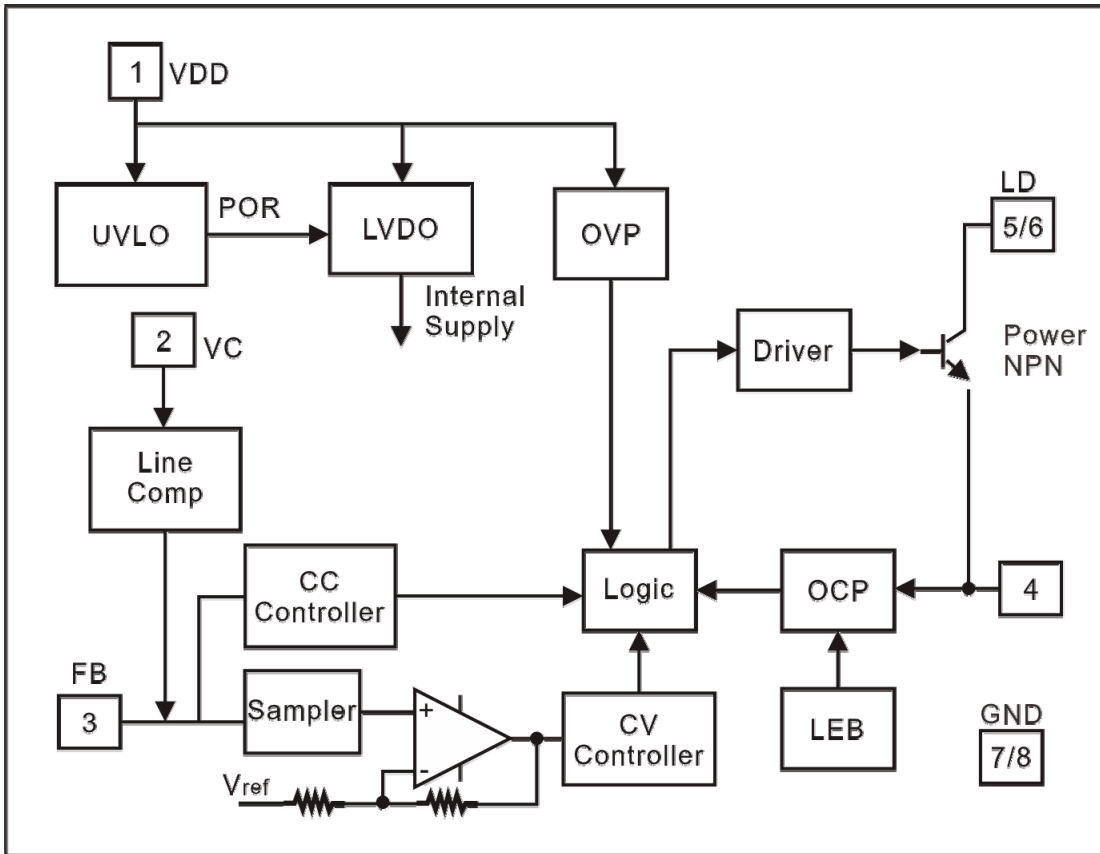

## APPLICAION CIRCUIT

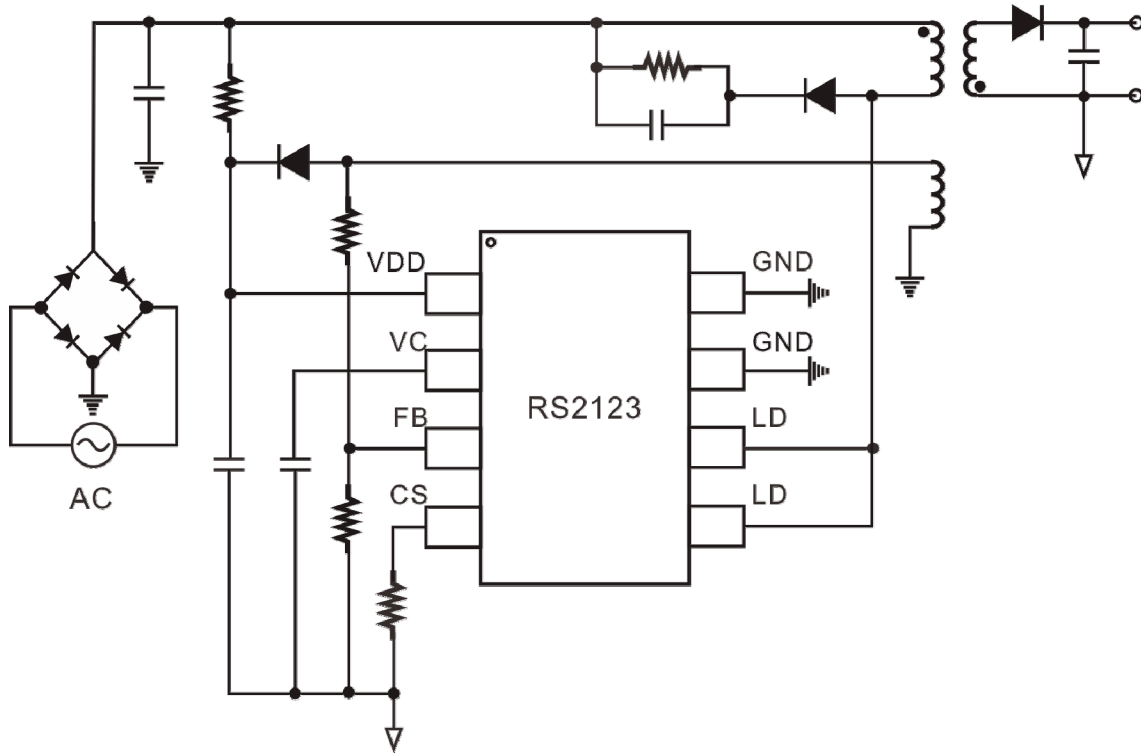

## ORDER INFORMATION

Device	Device Code
RS2123 Y Z	<p><b>Y is package &amp; Pin Assignments designator :</b> P : DIP-8</p> <p><b>Z is Lead Free designator :</b> P: Commercial Standard, Lead (Pb) Free and Phosphorous (P) Free Package G: Green (Halogen Free with Commercial Standard)</p>

# PIN ASSIGNMENTS

## DIP-8

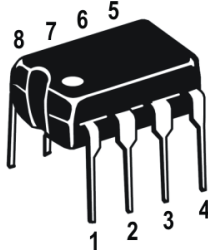

# PIN DESCRIPTION

Pin Name	Description	Pin No.
VDD	Supply voltage pin.	1
VC	Low pass filter capacitor for cable compensation	2
FB	Voltage feedback pin. Output current of this pin could controls the PWM duty cycle 、 OLP and SCP.	3
CS	Current sense pin, a resistor connects to sense the NPN current.	4
LD	The connector of NPN	5, 6
GND	GND Pin	7, 8