

DESCRIPTION

RS2122 is a high performance offline PSR controller for low power AC/DC charger and adapter applications. It operates in primary-side sensing and regulation. Consequently, opto-coupler and TL431 could be eliminated. Proprietary Constant Voltage (CV) and Constant Current (CC) control is integrated as shown in the figure below.

In CC control, the current and output power setting can be adjusted externally by the sense resistor R_s at CS pin. In CV control, PFM operations are utilized to achieve high performance and high efficiency. In addition, good load regulation is achieved by the built-in cable drop compensation. The chip consumes very low operation current (typical $400\mu\text{A}$), it can achieve less than 30mW standby power to meet strict standby power standard.

RS2122 offers comprehensive protection coverage with auto-recovery features including Cycle-by-Cycle current limiting, VDD over voltage protection, feedback loop open protection, short circuit protection, built-in leading edge blanking, VDD under voltage lockout (UVLO), etc.

FEATURES

- $\pm 5\%$ constant voltage regulation at universal AC input
- High precision constant current regulation at universal AC input
- Primary-side sensing and regulation without TL431 and opto-coupler
- Programmable CV and CC regulation
- Built-in primary winding inductance compensation
- Programmable cable drop compensation
- Built-in 700V power BJT
- Ultra low start-up current (Typ. $1\mu\text{A}$)
- VDD over voltage protection
- Built-in feedback loop open protection
- Built-in short circuit protection
- Built-in leading edge blanking (LEB)
- Cycle-by-cycle current limiting
- VDD under voltage lockout with hysteresis (UVLO)
- SOP-8 green packaging

APPLICATIONS

Low power AC/DC offline SMPS for

- Cell phone charger
- Digital cameras charger
- Small power adapter
- Auxiliary power for PC, TV etc.
- Linear regulator/RCC replacement

TYPICAL CC/CV CURVE

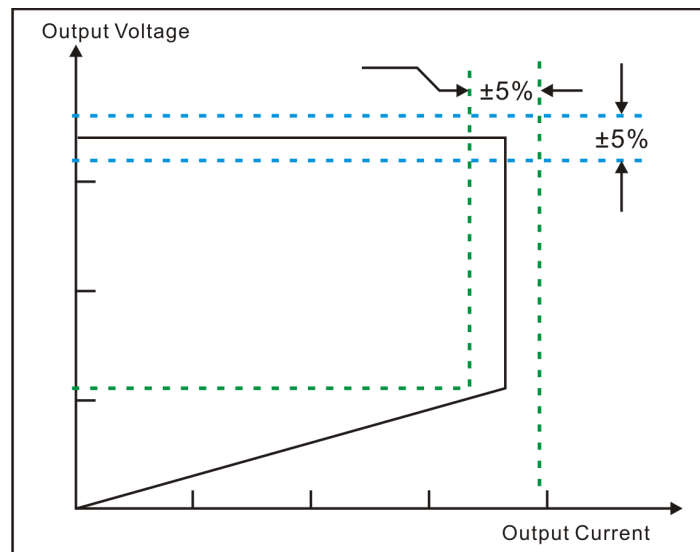

BLOCK DIAGRAM

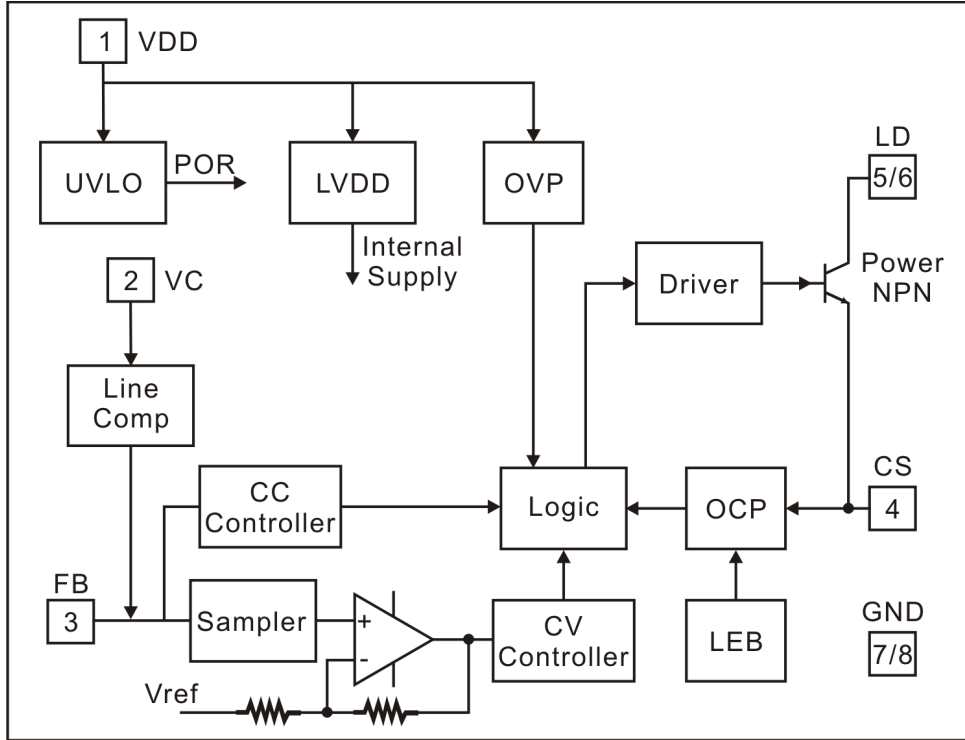

TYPICAL APPLICATION

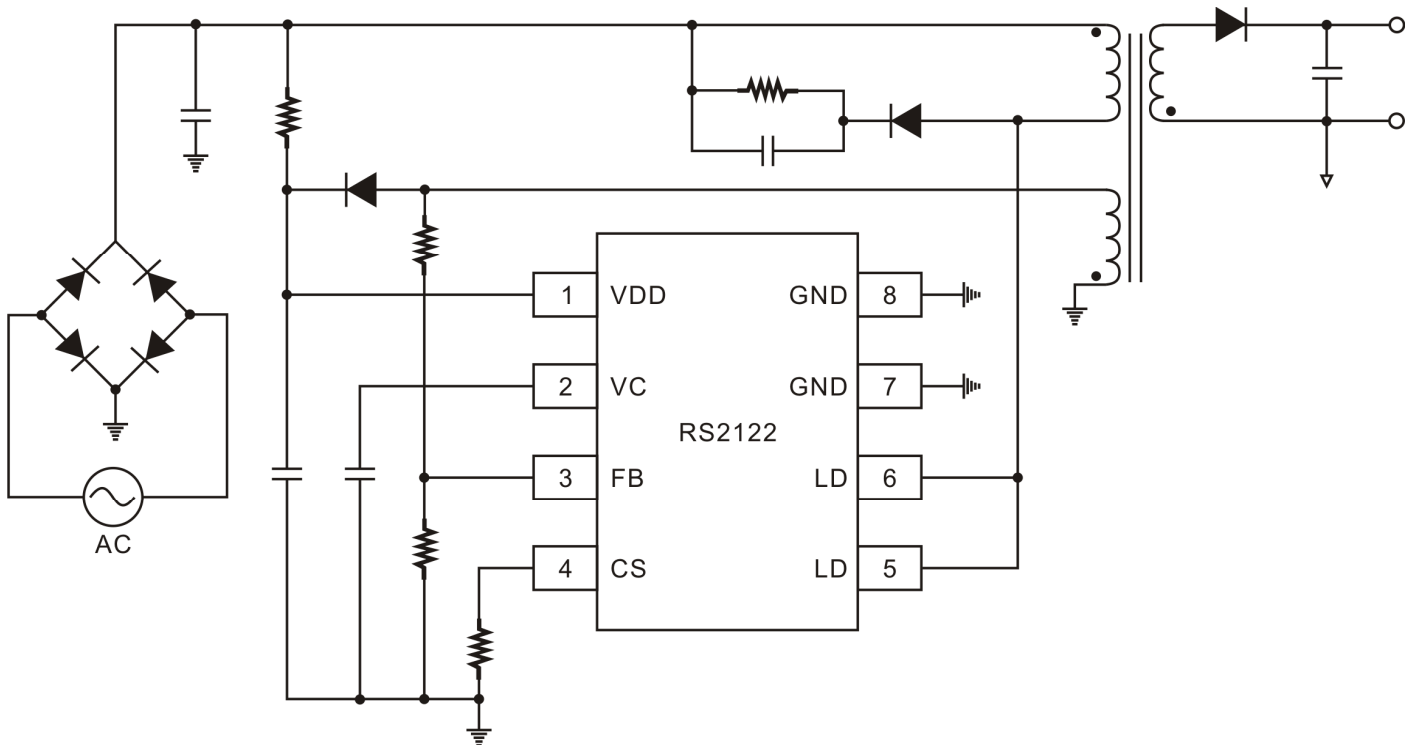

ORDER INFORMATION

Device	Device Code
RS2122 Y Z	Y is package & Pin Assignments designator: S: SOP-8 Z is Lead Free designator: P: Commercial Standard, Lead (Pb) Free and Phosphorous (P) Free Package G: Green (Halogen Free with Commercial Standard)

PIN ASSIGNMENTS

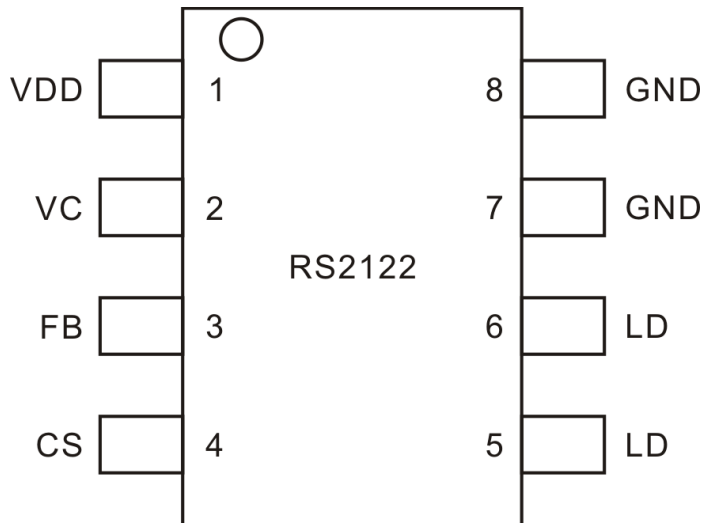

PIN DESCRIPTION

Pin Name	Description	Pin No.
VDD	Supply voltage pin.	1
VC	Low pass filter capacitor for cable compensation.	2
FB	Voltage feedback pin. Output current of this pin could controls the PWM duty cycle, OLP and SCP.	3
CS	Current sense pin, a resistor connects to sense the NPN current.	4
LD	The connector of NPN.	5
		6
GND	GND Pin.	7
		8

FUNCTION DESCRIPTION

RS2122 is a cost effective PSR controller optimized for off-line low power AC/DC applications including battery chargers. It operates in primary side sensing and regulation, thus opto-coupler and TL431 are not required. Proprietary built-in CV and CC control can achieve high precision CC/CV control meeting most charger application requirements.

STARTUP CURRENT AND START UP CONTROL

Startup current of RS2122 is designed to be very low so that VDD could be charged up above UVLO threshold and starts up quickly. A large value startup resistor can therefore be used to minimize the power loss in application.

OPERATING CURRENT

The Operating current of RS2122 is as low as 300μA. Good efficiency and very low standby power(less than 30mW) is achieved with the low operating current.

CC/CV OPERATION

RS2122 is designed to produce good CC/CV control characteristic as shown in the Page 1. In charger applications, a discharged battery charging starts in the CC portion of the curve until it is nearly full charged and smoothly switches to operate in CV portion of the curve. The CC portion provides output current limiting. In CV operation, the output voltage is regulated through the primary side control. In CC operation mode, RS2122 will regulate the output current constant regardless of the output voltage drop.

OPERATION DESCRIPTION

To support RS2122 proprietary CC/CV control, system needs to be designed in DCM mode for flyback system (Refer to Typical Application Diagram on page 2).

In the DCM flyback converter, the output voltage can be sensed via the auxiliary winding. During BJT turn-on time, the load current is supplied from the output filter capacitor, Co. The current in the primary winding ramps up.

When BJT turns off, the energy stored in the primary winding is transferred to the secondary side such that the current in the secondary winding is

$$I_S = \frac{N_P}{N_S} \times I_P \quad (1)$$

The auxiliary voltage reflects the output voltage as shown in Figure 1 and it is given by

$$V_{AUX} = \frac{N_{AUX}}{N_S} \times (V_O + \Delta V) \quad (2)$$

Where ΔV indicates the drop voltage of the output Diode.

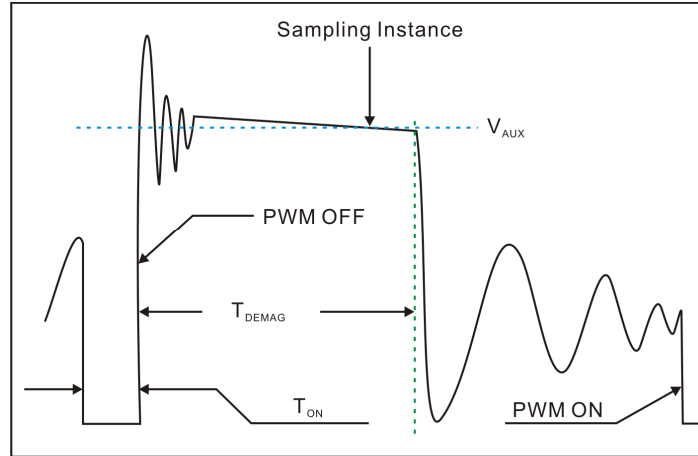

Figure 1. Auxiliary voltage waveform

Via a resistor divider connected between the auxiliary winding and FB (pin 4), the auxiliary voltage is sampled at the middle of the de-magnetization and it is hold until the next sampling. The sampled voltage is compared with V_{ref} (2.0V) and the error is amplified. The error amplifier output reflects the load condition and controls the switching off time to regulate the output voltage, thus constant output voltage can be achieved.

When the sampled voltage is below V_{ref} and the error amplifier output reaches its minimum, the switching frequency is controlled by the sampled voltage to regulate the output current, thus the constant output current can be achieved.

ADJUSTABLE CC POINT AND OUTPUT POWER

In RS2122, the CC point and maximum output power can be externally adjusted by external current sense resistor R_s at CS pin as illustrated in typical application diagram. The larger R_s , the smaller CC point is, and the smaller output power becomes, and vice versa as shown in Figure 2.

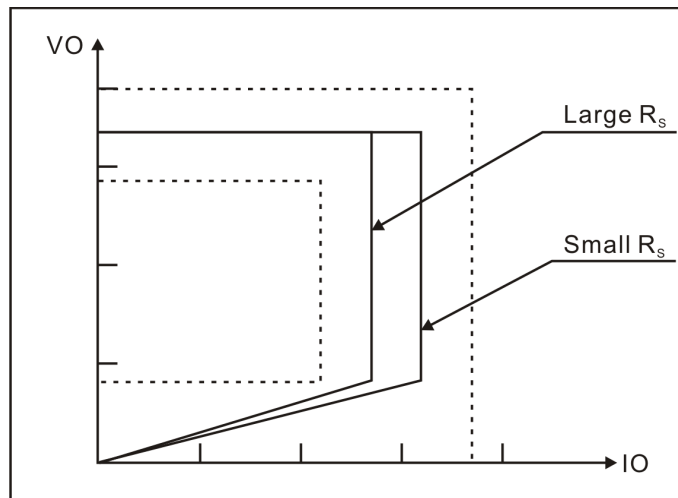

Figure 2. Adjustable output power by changing R_s

OPERATION SWITCHING FREQUENCY

The switching frequency of RS2122 is adaptively controlled according to the load conditions and the operation modes. For flyback operating in DCM, the maximum output power is given by

$$P_{o_{MAX}} = \frac{1}{2} L_P F_{SW} I_P^2 \quad (3)$$

Where L_P indicate the inductance of primary winding and I_P is the peak current of primary winding.

Refer to the equation 3, the change of the primary winding inductance results in the change of the maximum output power and the constant output current in CC mode. To compensate the change from variations of primary winding inductance, the switching frequency is locked by an internal loop such that the switching frequency is

$$F_{SW} = \frac{1}{2T_{DEMAG}} \quad (4)$$

Since T_{DEMAG} is inversely proportional to the inductance, as a result, the product L_P and F_{SW} is constant, thus the maximum output power and constant current in CC mode will not change as primary winding inductance changes. Up to $\pm 10\%$ variation of the primary winding inductance can be compensated.

PROGRAMMABLE CABLE DROP COMPENSATION

In RS2122, cable drop compensation is implemented to achieve good load regulation. An offset voltage is generated at FB pin by an internal current flowing into the resistor divider. The current is proportional to the switching off time, as a result, it is inversely proportional to the output load current, thus the drop due to the cable loss can be compensated. As the load current decreases from full-load to no-load, the offset voltage at FB will increase. It can also be programmed by adjusting the resistance of the divider to compensate the drop for various cable lines used.

The percentage of maximum compensation is

$$\frac{\Delta V}{V_{OUT}} = \frac{I_{comp_cable} \times (R1 // R2) \times 10^{-6}}{2} \times 100\%$$

Δ is load compensation voltage and V_{OUT} is output voltage. For example: $R1 // R2 = 6K\Omega$, the percentage of maximum compensation is

$$\frac{\Delta V}{V_{OUT}} = \frac{45 \times 6000 \times 10^{-6}}{2} \times 100\% = 13.5\%$$

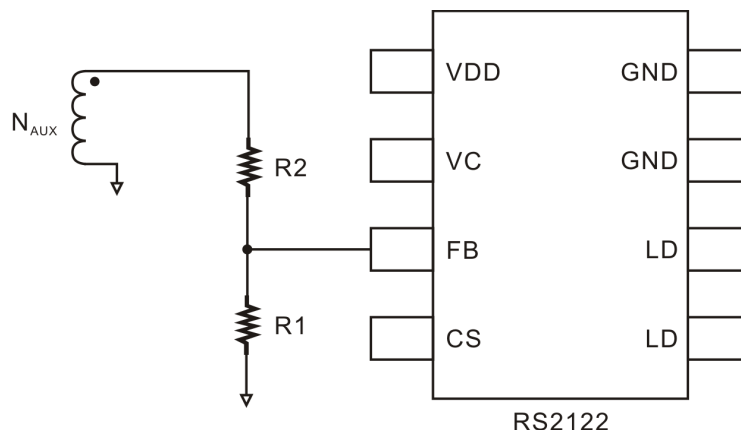

CURRENT SENSING AND LEADING EDGE BLANKING

Cycle-by-Cycle current limiting is offered in RS2122. The switch current is detected by a sense resistor into the CS pin. An internal leading edge blanking circuit chops off the sensed voltage spike at initial power BJT on state so that the external RC filtering on sense input is no longer needed.

BASE DRIVE

The drive is a push pull stage with supply voltage VDD. It provides the driving current for the external power bipolar transistor. The output signal is current limit to I_{s_max} (typical 30mA).

PROTECTION CONTROL

Good power supply system reliability is achieved with its rich protection features including Cycle-by-Cycle current limiting (OCP), VDD over voltage protection, feedback loop open protection, short circuit protection and Under Voltage Lockout on VDD (UVLO).

VDD is supplied by transformer auxiliary winding output. The output of RS2122 is shut down when VDD drops below UVLO (ON) and the power converter enters power on start-up sequence thereafter.

ABSOLUTE MAXIMUM RATINGS

Parameter	Symbol	Ratings	Unit
VDD voltage	-	0.3 ~ 30	V
VC voltage	-	0.3 ~ 7	V
BASE voltage	-	0.3 ~ 7	mA
CS input voltage	-	0.3 ~ 7	V
FB input voltage	-	0.3 ~ 7	V
LD supply voltage	-	-0.3 ~ 700	V
Junction temperature	T _J	-40 ~ 150	°C
Storage temperature range	T _{STG}	-40 ~ 150	°C
Lead temperature (Soldering, 10secs)	T _{LEAD}	260	°C

Note: Stresses beyond those listed under "absolute maximum ratings" may cause permanent damage to the device. These are stress ratings only, functional operation of the device at these or any other conditions beyond those indicated under "recommended operating conditions" is not implied. Exposure to absolute maximum-rated conditions for extended periods may affect device reliability.

ELECTRICAL CHARACTERISTICS

(T_A=25°C, VDD=15V, if not otherwise noted)

Parameter	Symbol	Test Condition	Min.	Typ.	Max.	Unit
Supply Voltage (VDD) Section						
Start up current	I start-up	VDD=11V	-	1	3	μA
Static current	I static	VDD=15V	-	350	500	μA
VDD under voltage lockout exit	UVLO(OFF)		11.5	12.5	13.5	V
VDD under voltage lockout enter	UVLO(ON)		6	7	8	V
VDD over voltage protection	VDD_OVP		25	27	29	V
Max. Operating Voltage			-	-	25	V
Current Sense Input Section						
LEB time	TLEB		-	0.5	-	μS
Over current threshold	Vth_ocp		390	420	450	mV
OCP propagation delay	Td_oc	From OCP comparator to base drive	-	100	-	ns
FB Input Section						
Reference voltage for feedback threshold	Vref_fb		1.98	2	2.02	V
Minimum pause	Tpause_min		-	2	-	μS
Maximum pause	Tpause_max		8	10	12	mS
Maximum cable compensation current	Icomp_cable		42	45	48	μA
BASE Drive Section						
Base sourcing maximum current	I _{s_max}		20	30	40	mA
Base sourcing current after pre-off	I _{s_preoff}		0.5	1	1.5	mA
Base drive low side on resistor	Rdson_l		-	1	-	Ω

CHARACTERISTICS CURVE

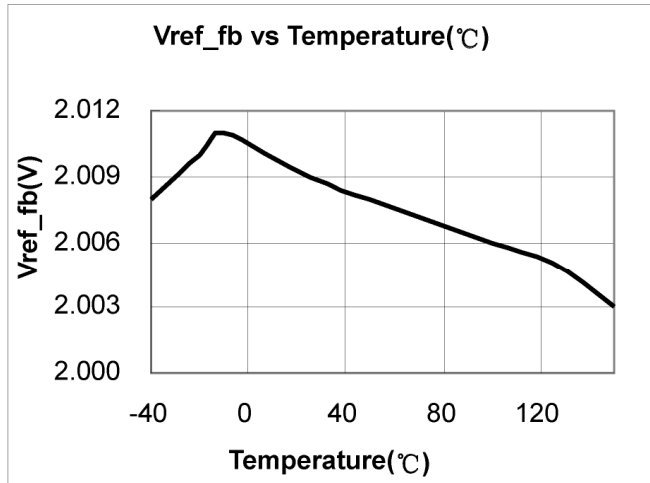
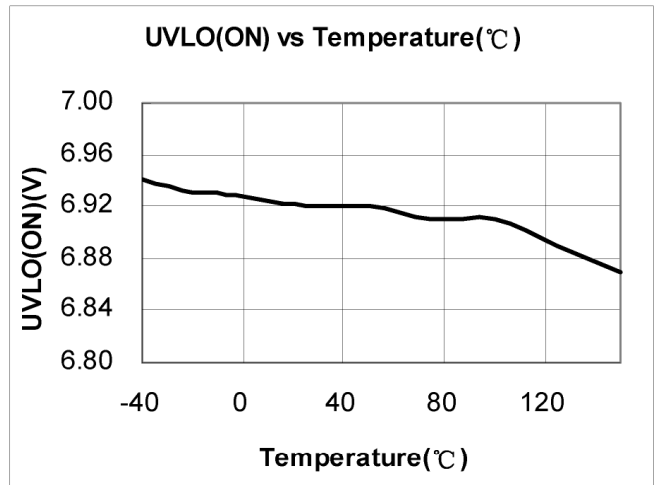
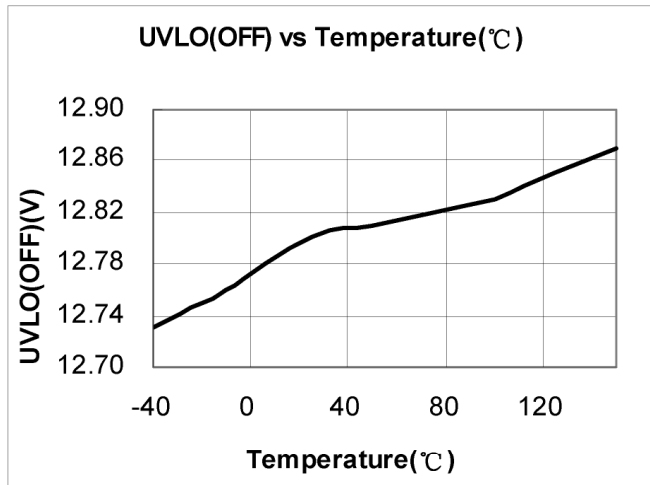
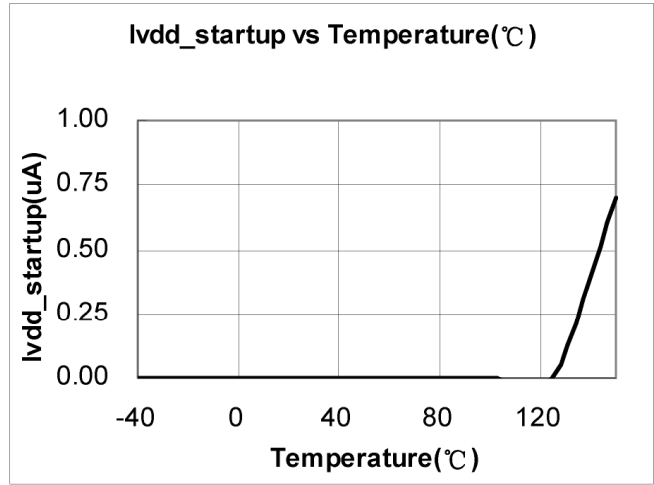
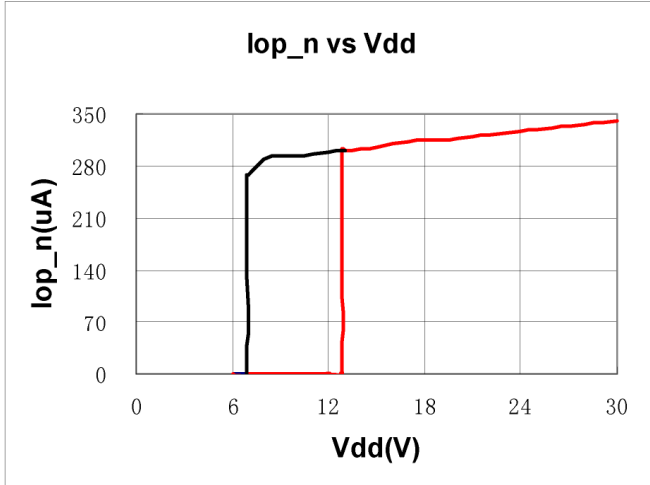



PACKAGE INFORMATION

8-PIN, SOP

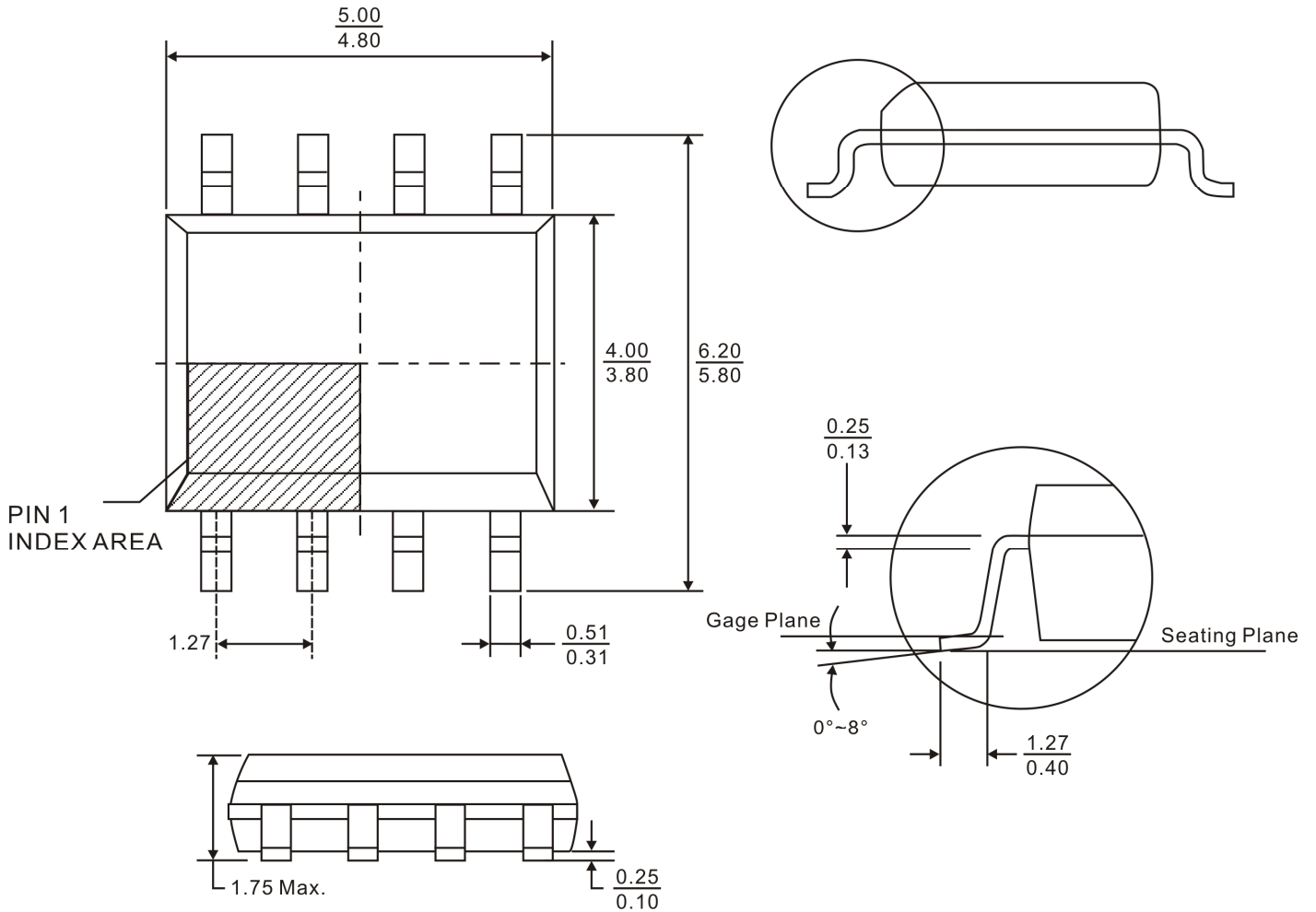

- Notes:
1. Refer to JEDEC MS-012 AA.
 2. All dimensions are in millimeter.

IMPORTANT NOTICE

Princeton Technology Corporation (PTC) reserves the right to make corrections, modifications, enhancements, improvements, and other changes to its products and to discontinue any product without notice at any time.

PTC cannot assume responsibility for use of any circuitry other than circuitry entirely embodied in a PTC product. No circuit patent licenses are implied.

Princeton Technology Corp.
2F, 233-1, Baociao Road,
Sindian Dist., New Taipei City 23145, Taiwan
Tel: 886-2-66296288
Fax: 886-2-29174598
<http://www.princeton.com.tw>



REVISION HISTORY

Date	Revision No.	Reference No.	Modification
01/25/2013	RS2122 V1.0	MAC1301011	1. Orister format modify to PTC format 2. P8, Absolute Maximum Rating, T_{STG} , -55+150 → -40~+150 3. Delete SOP-7 data