

DESCRIPTION

The RS8406 is a high efficiency monolithic synchronous buck regulator using a constant frequency, current mode architecture. The device is available in an adjustable version. Supply current with no load is 45uA and drops to <1uA in shutdown. The 2.7V to 5.5V input voltage range makes the RS8406 ideally suited for single Li-Ion, two to four AA battery-powered applications. 100% duty cycle provides low dropout operation, extending battery life in portable systems. In power saving mode, 45uA quiescent current is very suitable for DSP/MCU in standby operation; and in PWM mode, low output ripple voltage is good enough for noise sensitive applications. The two modes can be automatically switched according to the load current.

Switching frequency is internally set at 1.5MHz, allowing the use of small surface mount inductors and capacitors. The internal synchronous switch increases efficiency and eliminates the need for an external Schottky diode. Low output voltages are easily supported with the 0.6V feedback reference voltage. The RS8406 is available in a small SOT-23-5 package.

FEATURES

- High Efficiency: Up to 95%
- 1.5MHz Constant Switching Frequency
- Integrated Main switch and synchronous rectifier. No Schottky Diode Required
- Shutdown Current: <1μA
- 2.7V to 5.5V Input Voltage Range
- Output Voltage as Low as 0.6V
- 100% Duty Cycle in Dropout
- Quiescent Current : 45μA (TYP.)
- Slope Compensated Current Mode Control for Excellent Line and Load Transient Response
- Short Circuit Protection
- <1uA Shutdown Current

APPLICATIONS

- Smart Phones
- Set Top Box
- Personal Information Appliances
- Wireless and DSL Modems
- MP3 Players
- Portable Instruments

BLOCK DIAGRAM

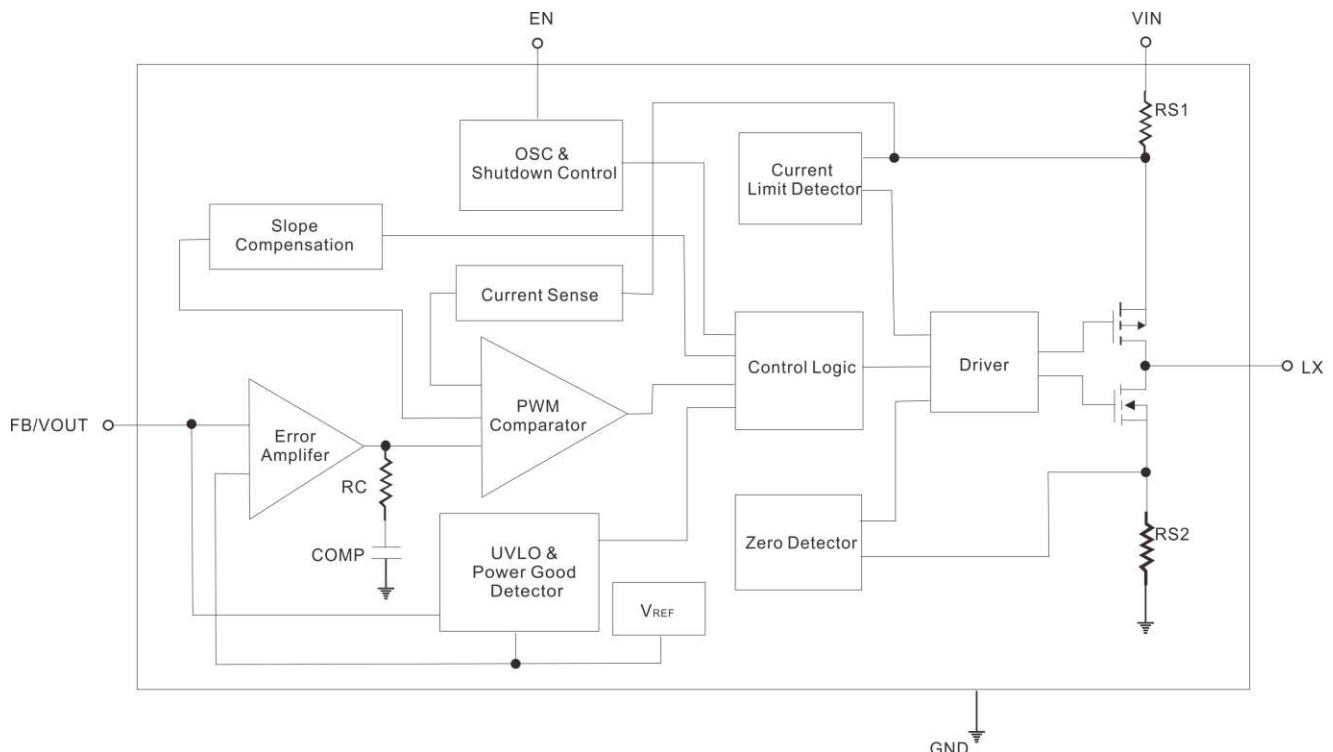

APPLICATION CIRCUIT

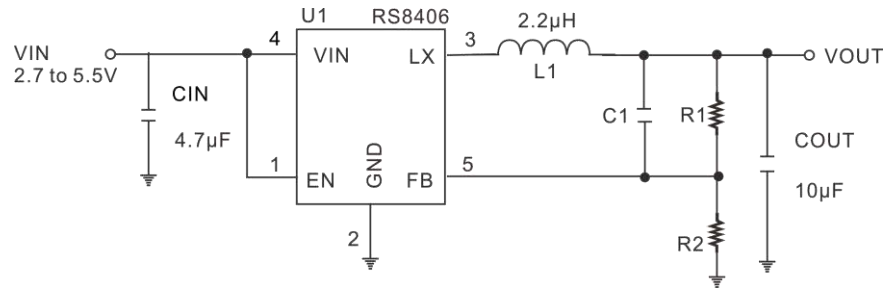

ORDER INFORMATION

Device	Device Code
RS8406-X Y Z	<p>X is nominal output voltage designator :</p> <p>A : ADJ</p> <p>Y is package designator :</p> <p>N: SOT-23-5</p> <p>Z is Lead Free designator :</p> <p>P: Commercial Standard, Lead (Pb) Free and Phosphorous (P) Free Package</p> <p>G: Green (Halogen Free with Commercial Standard)</p>

PIN ASSIGNMENTS

SOT-23

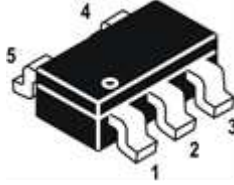

PIN DESCRIPTION

Pin Name	Description	PIN No.
EN	Regulator Enable control input. Drive LX above 1.25V to turn on the part. Drive LX below 0.55V to turn it off. In shutdown, all functions are disabled drawing <math><1\mu\text{A}</math> supply current. Do not leave LX floating.	1
GND	Ground.	2
LX	Power Switch Output. It is the Switch node connection to Inductor. This pin connects to the drains of the internal P-CH and N-CH MOSFET switches.	3
VIN	Supply Input Pin. Must be closely decoupled to GND, Pin 2, with a 2.2 μF or greater ceramic capacitor.	4
FB	Feedback Input Pin. Connect FB to the center point of the external resistor divider. The feedback threshold voltage is 0.6V.	5

IMPORTANT NOTICE

Princeton Technology Corporation (PTC) reserves the right to make corrections, modifications, enhancements, improvements, and other changes to its products and to discontinue any product without notice at any time. PTC cannot assume responsibility for use of any circuitry other than circuitry entirely embodied in a PTC product. No circuit patent licenses are implied.

Princeton Technology Corp.
2F, 233-1, Baociao Road,
Sindian Dist., New Taipei City 23145, Taiwan
Tel: 886-2-66296288
Fax: 886-2-29174598
<http://www.princeton.com.tw>