

## DESCRIPTION

RS6514 provides low-ripple power, high efficiency, and excellent transient characteristics. The PWM control circuit is able to vary the duty ratio linearly from 0 up to 100%. This converter also contains an error amplifier circuit as well as a soft-start circuit that prevents overshoot at startup. An enable function, an over current protect function and a short circuit protect function are built inside, and when OCP or SCP happens, the operation frequency will be reduced from 350KHz to 30KHz. Also, an internal compensation block is built in to minimum external component count.

With the addition of an internal P-Channel Power MOS, a coil, capacitors, and a diode connected externally, these ICs can function as step-down switching regulators. They serve as ideal power supply units for portable devices when coupled with the SOP-8/EP (Exposed Pad) mini-package, providing such outstanding features as low current consumption. Since this converter can accommodate an input voltage up to 20V, it is also suitable for the operation via an AC adapter.

## FEATURES

- Input voltage: 3.6V to 20V.
- Output voltage: 0.8V to VCC.
- Duty ratio: 0% to 100% PWM control
- Oscillation frequency: 350KHz typ.
- Soft-start, Current limit, Enable function
- Thermal Shutdown function
- Built-in internal SW P-channel MOS
- SOP-8L Pb-Free Package. Programmable under voltage lockout

## APPLICATIONS

- PC Motherboard
- LCD Monitor
- Graphic Card
- DVD-Video Player
- Telecom Equipment
- ADSL Modem
- Printer and other Peripheral Equipment
- Microprocessor core supply
- Networking power supply Pre-regulator for linear regulators

## BLOCK DIAGRAM

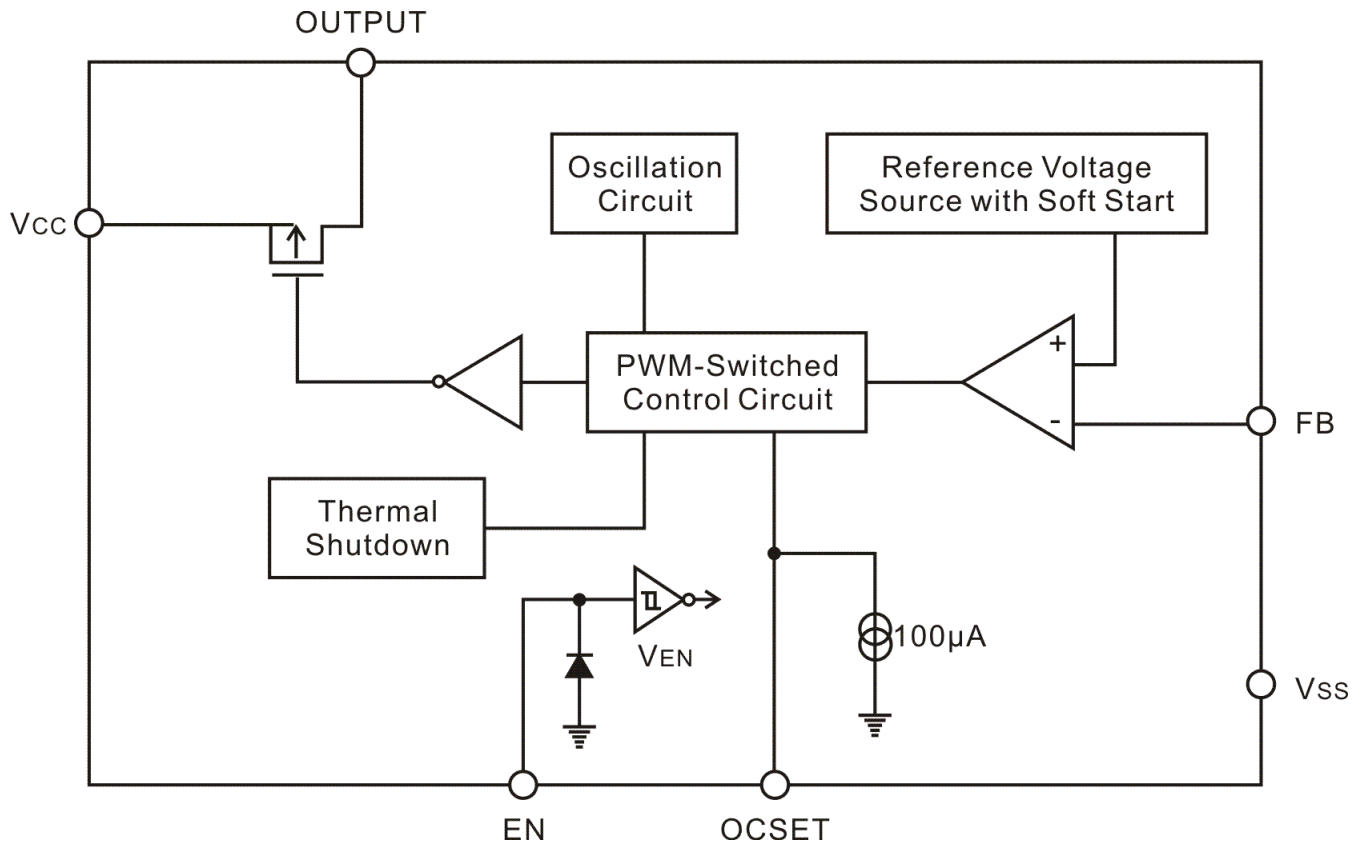



## APPLICATION CIRCUIT

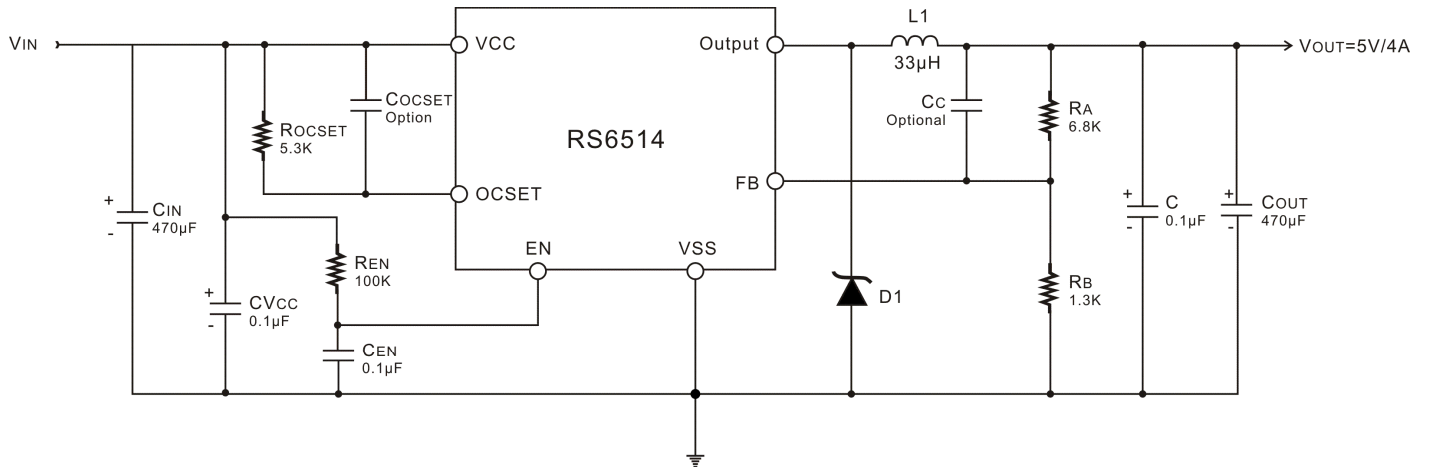

Note:  $V_{OUT} = V_{FB} \times (1 + R_A / R_B)$   
 $R_B = 0.7K \sim 5K\Omega$

$V_{IN} = 12V, I_{MAX} = 4A$			
$V_{OUT}$	2.5V	3.3V	5V
L1 Value	22µH	27µH	33µH

## ORDER INFORMATION

Part No	Package
RS6514SE	SOP-8/EP

# PIN ASSIGNMENTS

## SOP-8 (EP)

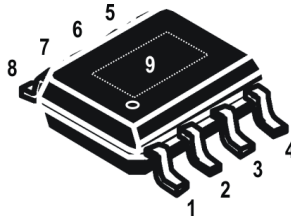

# PIN DESCRIPTION

Pin Name	Description	Pin No.
FB	Feedback pin	1
EN	Power-off pin H: Normal operation(Step-down operation) L: Step-down operation stopped(All circuits deactivated)	2
OCSET	Add an external resistor to set max output current	3
V <sub>CC</sub>	IC power supply pin	4
Output	Output pin. Connect external inductor/diode here. Minimize trace area at this pin to reduce EMI	5, 6, 9
V <sub>SS</sub>	GND pin	7~8

## **FUNCTION DESCRIPTION**

### ***PWM CONTROL***

The RS6514 consists of DC/DC converters that employ a pulse-width modulation (PWM) system. In converters of the RS6514, the pulse width varies in a range from 0 to 100%, according to the load current. The ripple voltage produced by the switching can easily be removed through a filter because the switching frequency remains constant. Therefore, these converters provide a low-ripple power over broad ranges of input voltage and load current.

### ***UNDER VOLTAGE LOCKOUT***

The under voltage lockout circuit of the RS6514 assures that the high-side MOSFET driver outputs remain in the off state whenever the supply voltage drops below 3.3V. Normal operation resumes once  $V_{CC}$  rises above 3.5V.

### ***R<sub>DS(ON)</sub> CURRENT LIMITING***

The current limit threshold is setting by the external resistor connecting from  $V_{CC}$  supply to OCSET. The internal 100uA sink current crossing the resistor sets the voltage at the pin of OCSET. When the PWM voltage is less than the voltage at OCSET, an over-current condition is triggered.

### ***INDUCTOR SELECTION***

The inductor value and operating frequency determine the ripple current according to a specific input and output voltage. The ripple current  $\Delta I_L$  increases with higher  $V_{IN}$  and decreases with higher inductance.

$$I_{LOAD} \times R_{DS(ON)} = I_{OCSET} \times R_{OCSET}$$

See above formula for setting the current limit value.

# TYPICAL PERFORMANCE CHARACTERISTICS

Vin vs. FB

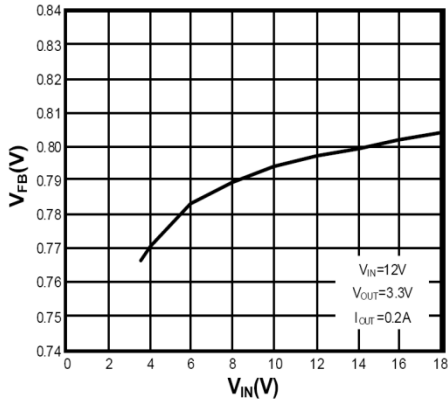

Line Regulation

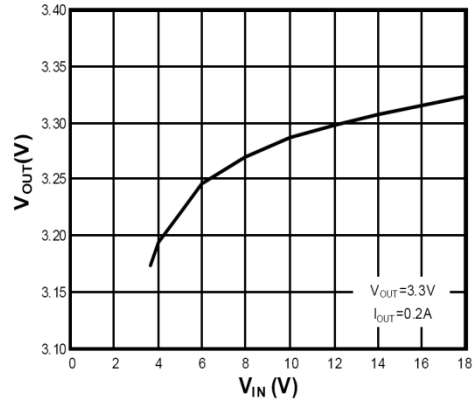

Load Regulation

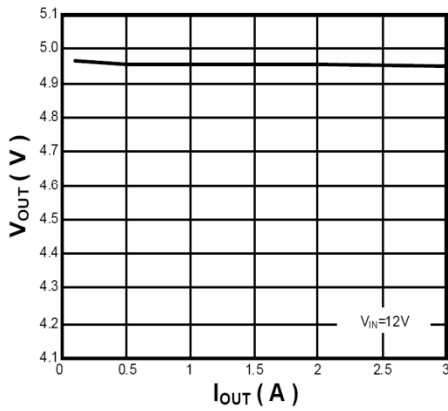

VIN v.s Frequency

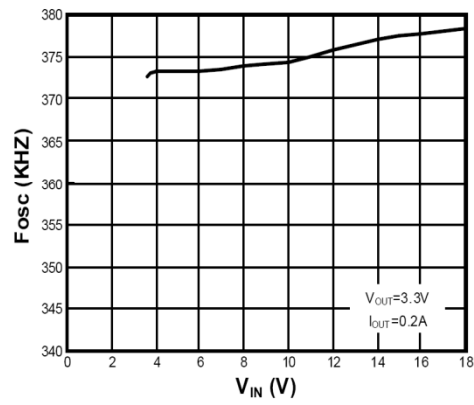

Efficiency

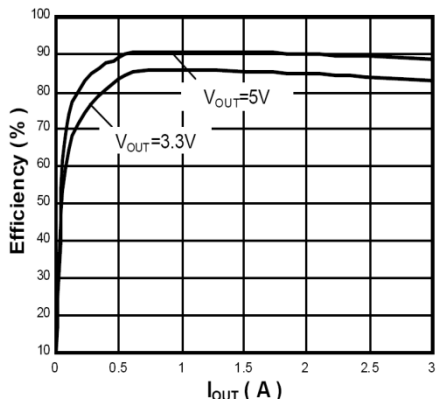

Vout Ripple

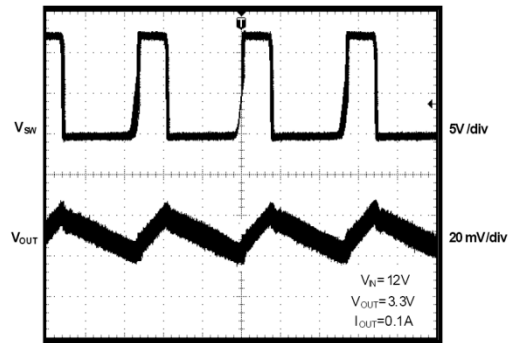

Vout Ripple

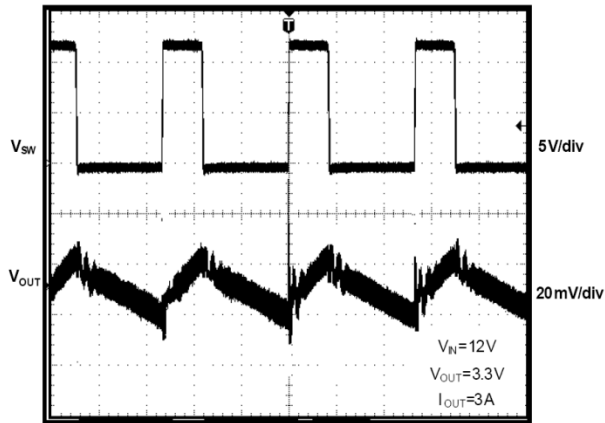

Frequency of short current protect

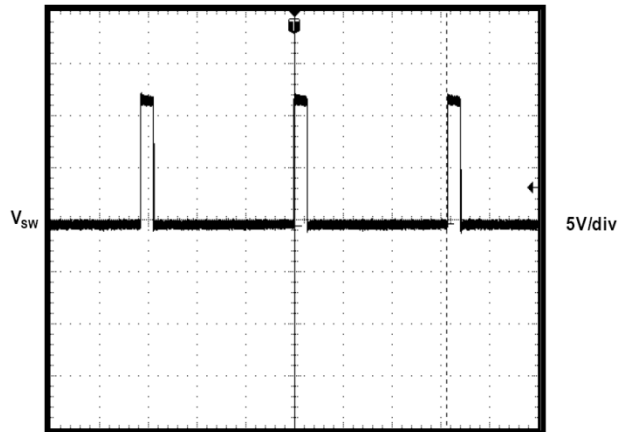

Soft start time

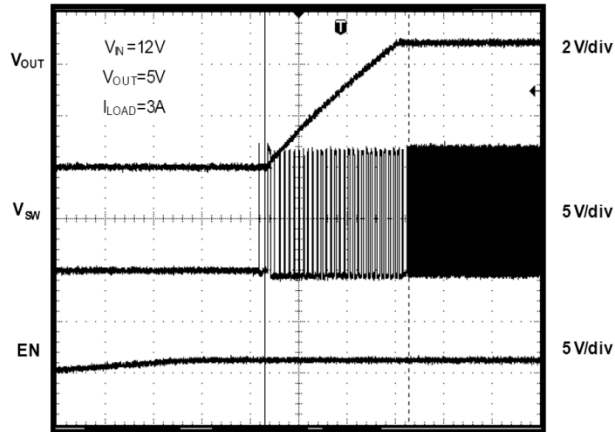

## ABSOLUTE MAXIMUM RATINGS

Parameter	Symbol	Range	Units
V <sub>CC</sub> Pin Voltage	V <sub>CC</sub>	V <sub>SS</sub> -0.3 to V <sub>SS</sub> +22	V
Feedback Pin Voltage	V <sub>FB</sub>	V <sub>SS</sub> -0.3 to V <sub>CC</sub>	V
EN Pin Voltage	V <sub>EN</sub>	V <sub>SS</sub> -0.3 to V <sub>IN</sub> +0.3	V
Feedback voltage	V <sub>OUTPUT</sub>	V <sub>SS</sub> -0.3 to V <sub>IN</sub> +0.3	V
Power Dissipation	P <sub>D</sub>	Internally limited	mW
Operating Temperature Range	T <sub>OPR</sub>	-20 to +125	°C
Storage Temperature Range	T <sub>STG</sub>	-40 to +150	°C

## ELECTRICAL CHARACTERISTICS

(V<sub>IN</sub>=12V, T<sub>A</sub>=25°C, unless otherwise specified)

Parameter	Symbol	Conditions	Min.	Typ.	Max.	Unit
Input Voltage	V <sub>IN</sub>	-	3.6	-	20	V
Feedback voltage	V <sub>FB</sub>	I <sub>OUT</sub> =0.1A	0.782	0.8	0.818	V
Feedback Bias Current	I <sub>FB</sub>	I <sub>OUT</sub> =0.1A	-	0.1	0.5	μA
Switch Current	I <sub>SW</sub>	-	4.5	-	-	A
Current Consumption During Power Off	I <sub>SSS</sub>	V <sub>EN</sub> =0V	-	10	-	μA
Line Regulation	ΔV <sub>OUT</sub> /V <sub>OUT</sub>	V <sub>IN</sub> =5V~18V	-	2	4	%
Load Regulation	ΔV <sub>OUT</sub> /V <sub>OUT</sub>	I <sub>OUT</sub> =0.1~4A	-	0.2	0.5	%
Oscillation Frequency	F <sub>OSC</sub>	Measure waveform at SW pin	300	350	400	KHz
Frequency of Current Limit or Short Circuit Protect	F <sub>OSC1</sub>	Measure waveform at SW pin	10	-	-	KHz
EN Pin Input Voltage	V <sub>SH</sub>	Evaluate oscillation at SW pin	2.0	-	-	V
	V <sub>SL</sub>	Evaluate oscillation stop at SW pin	-	-	0.8	
EN Pin Input Leakage Current	I <sub>SH</sub>	-	-	20	-	μA
	I <sub>SL</sub>	-	-	-10	-	
OCSET Pin Bias Current	I <sub>OCSET</sub>	-	75	90	105	μA
Soft-Start Time	T <sub>SS</sub>	-	0.3	2	5	ms
Internal MOSFET RDSON	R <sub>DSON</sub>	V <sub>IN</sub> =5V, V <sub>FB</sub> =0V	-	110	150	mΩ
		V <sub>IN</sub> =12V, V <sub>FB</sub> =0V	-	70	100	
Efficiency	EFFI	V <sub>IN</sub> =12V, V <sub>OUT</sub> =5V, I <sub>OUT</sub> =4A	-	90	-	%
Thermal Resistance Junction-to-Ambient	θ <sub>JA</sub>	-	-	65	-	°C/W
Thermal shutdown	T <sub>SD</sub>	-	-	160	-	°C



# PACKAGE INFORMATION

## 8-PIN, SOP (EP)

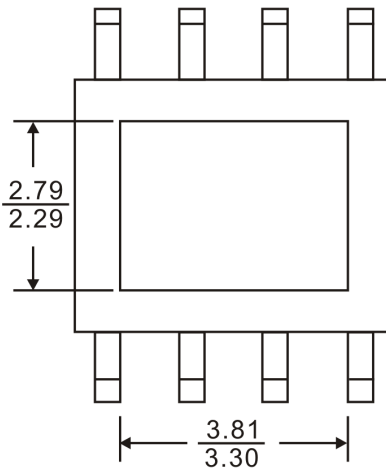
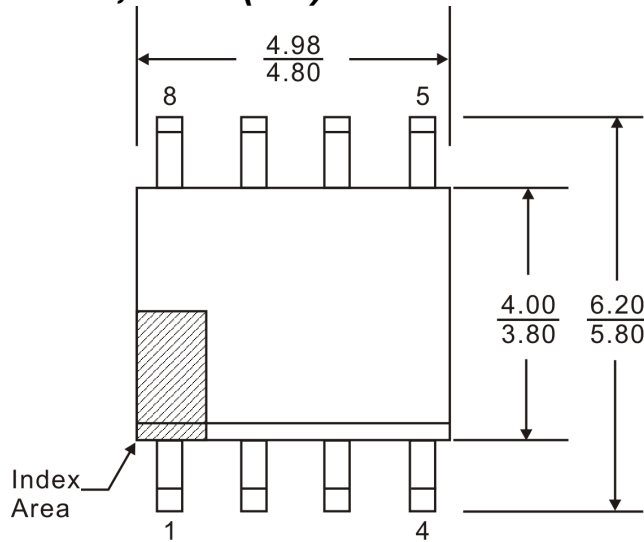

Bottom View  
Heat Sink

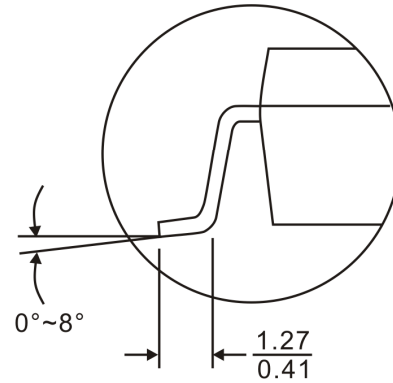
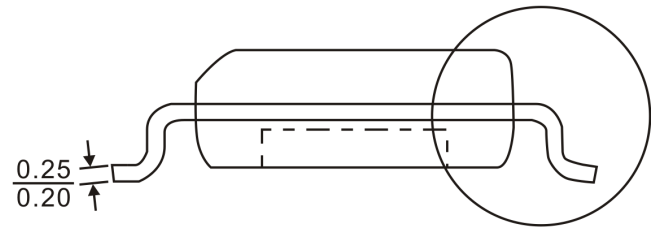
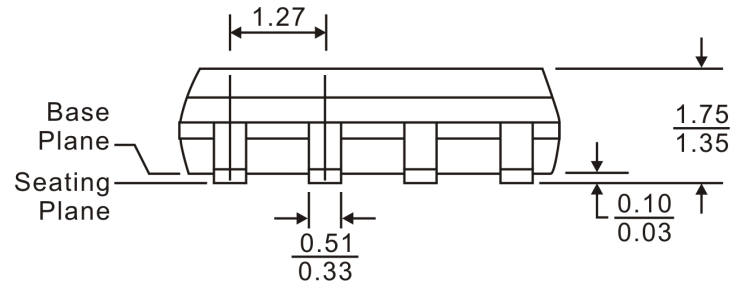

Notes:

1. Refer to JEDEC MS-012 AA.
2. All dimensions are in millimeter.



## **IMPORTANT NOTICE**

Princeton Technology Corporation (PTC) reserves the right to make corrections, modifications, enhancements, improvements, and other changes to its products and to discontinue any product without notice at any time.

PTC cannot assume responsibility for use of any circuitry other than circuitry entirely embodied in a PTC product. No circuit patent licenses are implied.

Princeton Technology Corp.  
2F, 233-1, Baociao Road,  
Sindian Dist., New Taipei City 23145, Taiwan  
Tel: 886-2-66296288  
Fax: 886-2-29174598  
<http://www.princeton.com.tw>