

## DESCRIPTION

The RS2596 is Monolithic IC that design for a step-down DC/DC Converter, and own the ability of driving a 3A load without additional transistor component.

The output version included 3.3V, 5V, 12V and an adjustable type. It operates at a switching frequency of 150KHz thus allowing smaller sized filter components than what would be needed with lower frequency switching regulators. Other features include a guaranteed 4% tolerance on output voltage under specified input voltage and output load conditions, and 15% on the oscillator frequency. Regarding protected function, thermal shutdown is to prevent over temperature operating from damage, and current limit is against over current operating of the output switch.

## FEATURES

- 3.3V, 5V, 12V and adjustable
- Adjustable version output voltage range: 1.23-37V
- 4% max over line and load conditions
- 150KHz 15% fixed switching frequency
- TTL shutdown capability
- Operating voltage can be up to 40V
- Output load current: 3A
- TO220-5, TO263-5 packages
- Low power standby mode
- Thermal-shunt down and current-limit protection
- Built-in switching a transistor on chip, requires only 4 external components

## APPLICATIONS

- Simple High-efficiency step-down regulator
- Positive to negative converter
- On-card switching regulators

## BLOCK DIAGRAM

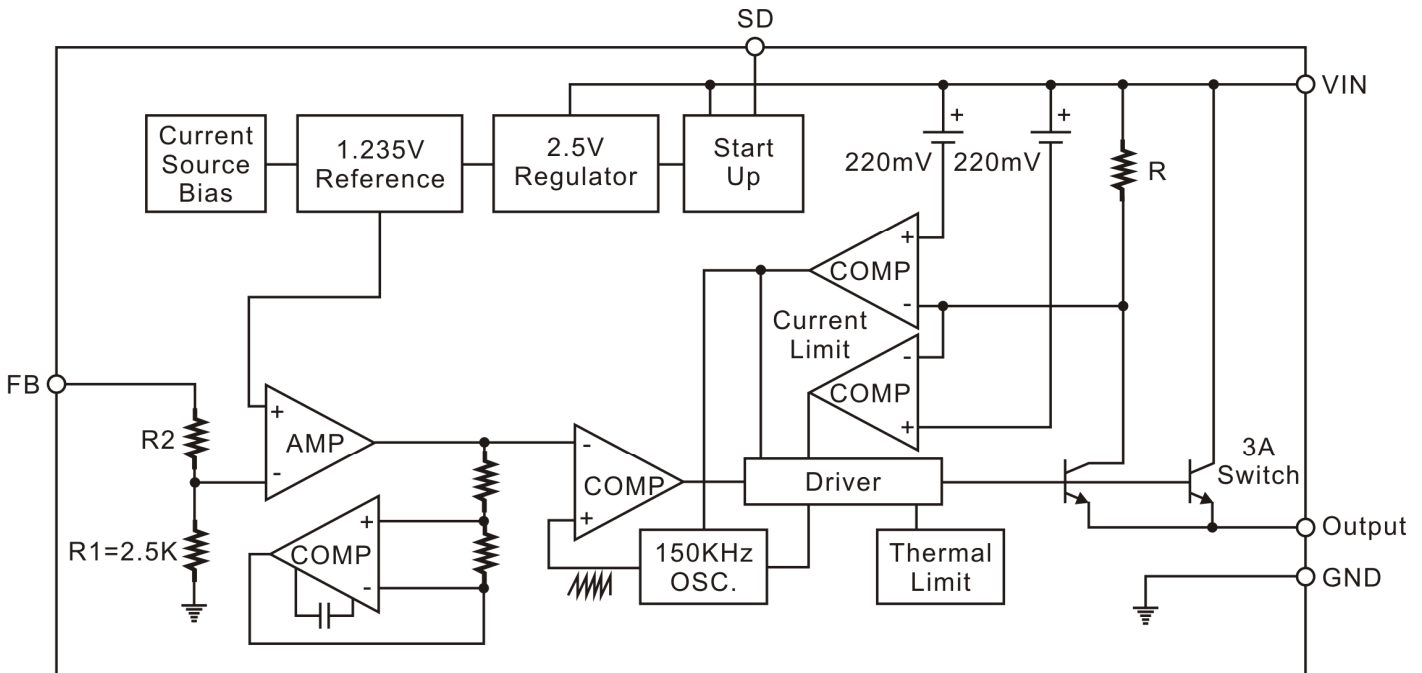

## APPLICATION CIRCUIT

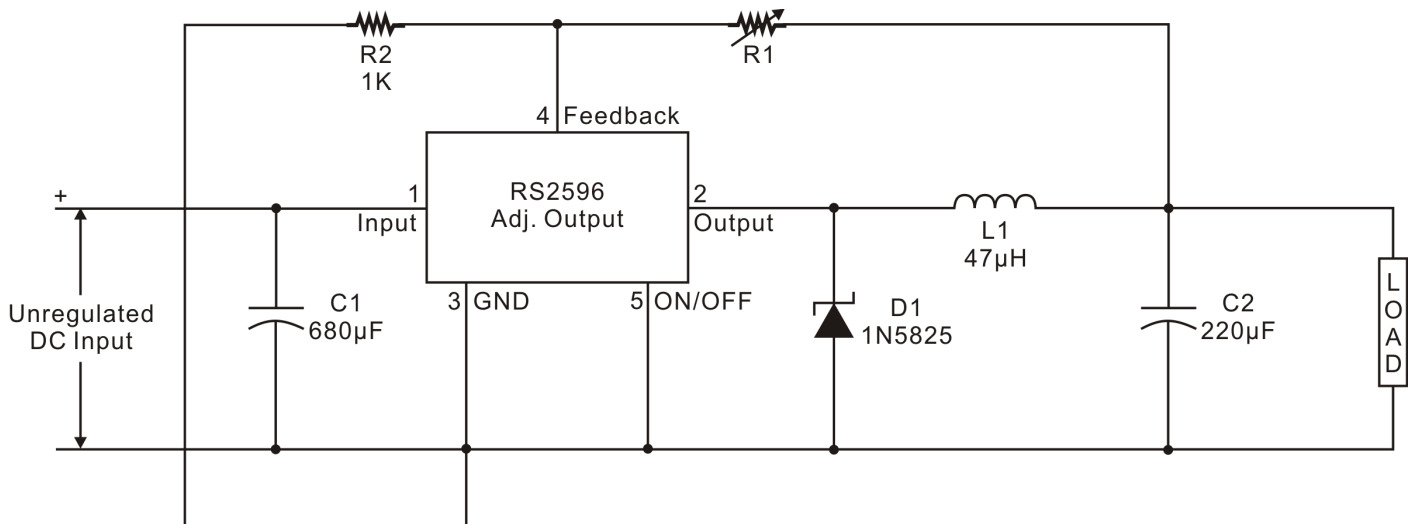

## ORDER INFORMATION

Device	Device Code
RS2596-XX Y Z	<p><b>XX is nominal output voltage (for example, AD=ADJ, 33=3.3V, 50=5.0V, 12=12V).</b></p> <p><b>Y is package designator:</b>                      U: TO-263-5                      E: TO-220-5</p> <p><b>Z is Lead Free designator:</b>                      P: Commercial Standard, Lead (Pb) Free and Phosphorous (P) Free Package                      G: Green (Halogen Free with Commercial Standard)</p>

## PIN CONFIGURATION

TO-263-5

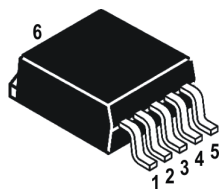

TO-220-5

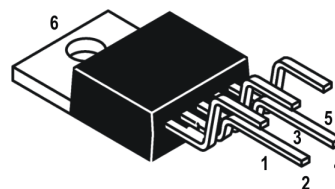

## PIN DESCRIPTION

Pin Name	Description	Pin No.	
		TO-263-5	TO-220-5
VIN	Regulator Input Pin	1	1
VOUT	Regulator Output Pin	2	2
GND	Ground Pin	3, 6	3, 6
FB	Output Voltage Feed Back Control Pin	4	4
SD	ON/OFF Shutdown Pin	5	5

## ABSOLUTE MAXIMUM RATINGS (NOTE1)

Parameter	Symbol	Range	Units
Supply voltage	$V_{CC}$	40	V
On/Off pin input voltage	$V_{SD}$	-0.3~+25	V
Feedback pin voltage	$V_{FB}$	-0.3~+25	V
Output voltage to ground	$V_{OUT}$	-1	V
Power dissipation	$P_D$	Internally Limited	W
Operating temperature	$T_{opr}$	0~+70	°C
Storage temperature	$T_{stg}$	-40~+150	°C
Operating junction temperature range	$T_J$	-40~+125	°C
Operating voltage	$V_{OP}$	+4.5~+40	V

## ELECTRICAL CHARACTERISTICS (CONTINUED)

Specifications with boldface type apply over for full operating temperature range, the other type are for  $T_J=25^{\circ}\text{C}$  (Note 2)

Part No.	Parameter	Symbol	Conditions	Min.	Typ. (Note3)	Max. (Note4)	Unit
RS2596-3.3V	Output voltage	$V_{OUT}$	$5V \leq V_{IN} \leq 40V, 0.2A \leq I_{LOAD} \leq 3A$	3.168 3.135	3.3	3.342 3.465	V
	Efficiency	$\eta$	$V_{IN}=12V, I_{LOAD}=3A$	-	72	-	%
RS2596-5.0V	Output voltage	$V_{OUT}$	$7V \leq V_{IN} \leq 40V, 0.2A \leq I_{LOAD} \leq 3A$	4.800 4.750	5.0	5.200 5.250	V
	Efficiency	$\eta$	$V_{IN}=12V, I_{LOAD}=3A$	-	79	-	%
RS2596-12V	Output voltage	$V_{OUT}$	$15V \leq V_{IN} \leq 40V, 0.2A \leq I_{LOAD} \leq 3A$	11.52 11.40	12.0	12.48 12.60	V
	Efficiency	$\eta$	$V_{IN}=25V, I_{LOAD}=3A$	-	90	-	%
RS2596-ADJ	Reference voltage	$V_{FB}$	$4.5V \leq V_{IN} \leq 40V, 0.2A \leq I_{LOAD} \leq 3A$ $V_{OUT}$ programmed for 3V	1.193	1.230	1.267 1.280	V
	Efficiency	$\eta$	$V_{IN}=12V, I_{LOAD}=3A$	-	72	-	%

# ALL OUTPUT VOLTAGE VERSIONS ELECTRICAL CHARACTERISTICS

Specifications with **boldface type** apply over for full operating temperature range, the other type are for  $T_J=25^{\circ}\text{C}$  (Unless otherwise specified,  $V_{IN}=12\text{V}$  for the 3.3V, 5V, and adjustable version and  $V_{IN}=24\text{V}$  for the 12V version,  $I_{LOAD}=500\text{mA}$ )

Parameter	Symbol	Test Condition	Min.	Typ.	Max.	Unit	
<b>Device Parameters</b>							
Feedback bias current	$I_b$	Adjustable version only, $V_{FB}=1.3\text{V}$	-	40	50 100	nA	
Oscillator frequency	$f_o$	(Note 5)	127 110	150	173 173	KHz	
Saturation voltage	$V_{SAT}$	$I_{OUT}=3\text{A}$ (Note 6, 7)	-	1.16	1.4 1.5	V	
Max. duty cycle (ON) Min. duty cycle (OFF)	DC	(Note 7) (Note 8)	-	100 0	-	%	
Current limit	$I_{CL}$	Peak current (Note 6, 7)	3.6	-	5.5 6.9	A	
Output leakage current	$I_L$	Output=0V (Note 6, 8)	-	-	50	$\mu\text{A}$	
Quiescent current	$I_Q$	(Note 8)	-	5	30	mA	
Standby quiescent current	$I_{STBY}$	ON/OFF pin=5V (Note 9)	-	85	200 300	$\mu\text{A}$	
Thermal resistance	$\theta_{JC}$	TO220-5	Junction to case	-	2.5	-	$^{\circ}\text{C}/\text{W}$
		TO263-5		-	3.5	-	
	$\theta_{JA}$ (Note 10)	TO220-5	Junction to ambient	-	28	-	$^{\circ}\text{C}/\text{W}$
		TO263-5		-	30	-	
<b>ON/OFF Control</b>							
ON/OFF pin logic input threshold voltage	$V_{IH}$	Low (Regulator ON)	-	1.4	0.6	V	
	$V_{IL}$	High (Regulator OFF)	2.0		-		
ON/OFF pin input current	$I_{IH}$	$V_{LOGIC}=2.5\text{V}$ (Regulator OFF)	-	6	15	$\mu\text{A}$	
	$I_{IL}$	$V_{LOGIC}=0.5\text{V}$ (Regulator ON)	-	0.02	5		

Notes:

- Absolute Maximum Ratings indicate limits beyond which damage to the device may occur. Operating Ratings indicate conditions for which the device is intended to be functional, but do not guarantee specific performance limits. For guaranteed specifications and test conditions, see the Electrical Characteristics.
- External components such as the catch diode, inductor, input and output capacitors, and voltage programming resistors can affect switching regulator system performance.
- Typical numbers are at  $25^{\circ}\text{C}$  and represent the most likely norm.
- All limits guaranteed at room temperature (standard type face) and at temperature extremes (bold type face). All room temperature limits are 100% production tested. All limits at temperature extremes are guaranteed via correlation using standard Statistical Quality Control (SQC) methods. All limits are used to calculate Average Outgoing Quality Level (AOQL).
- The switching frequency is reduced when the second stage current limit is activated.
- No diode, inductor or capacitor connected to output pin.
- Feedback pin removed from output and connected to 0V to force the output transistor switch ON.
- Feedback pin removed from output and connected to 12V for the 3.3V, 5V, ADJ. version, and 15V for the 12V version, to force the output transistor switch OFF.
- $V_{IN}=40\text{V}$ .
- Junction to ambient thermal resistance. (With copper area of approximately  $3\text{in}^2$ )

# CHARACTERISTICS CURVE

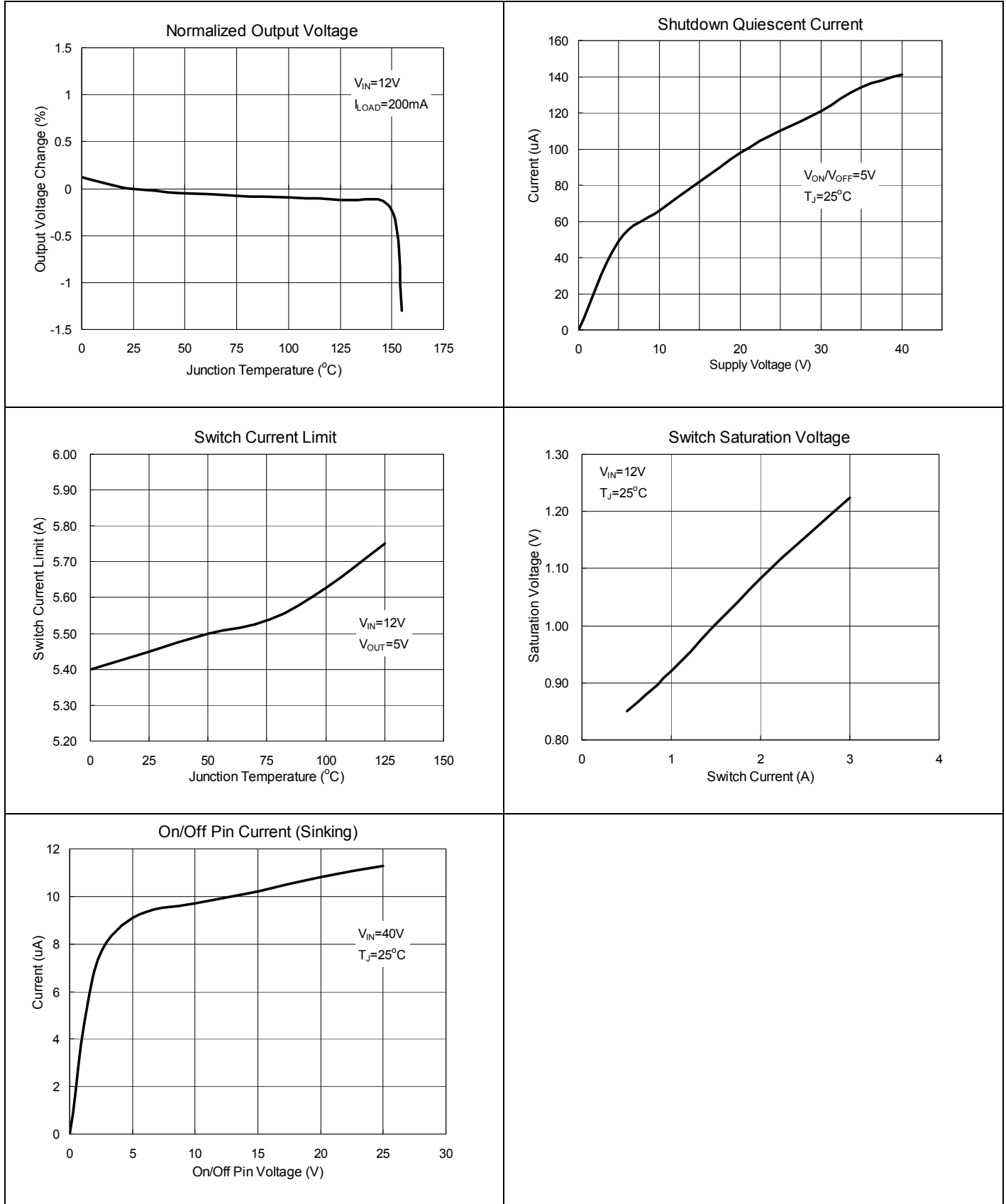

# PACKAGE INFORMATION

## TO-263-5

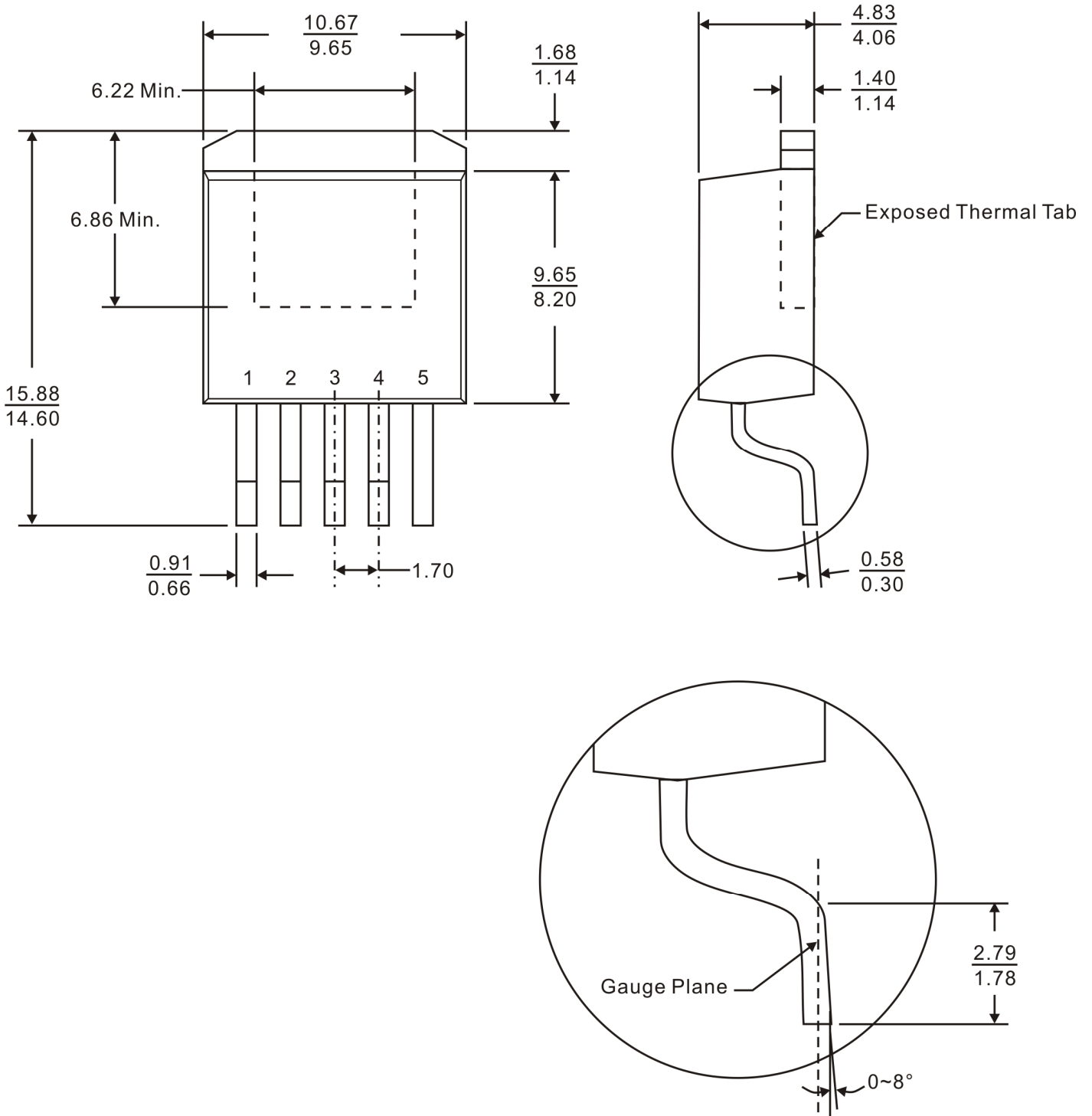

Notes:  
 1. Refer to JEDEC TO-263 BA.  
 2. All dimensions are in millimeter.

**TO-220-5**

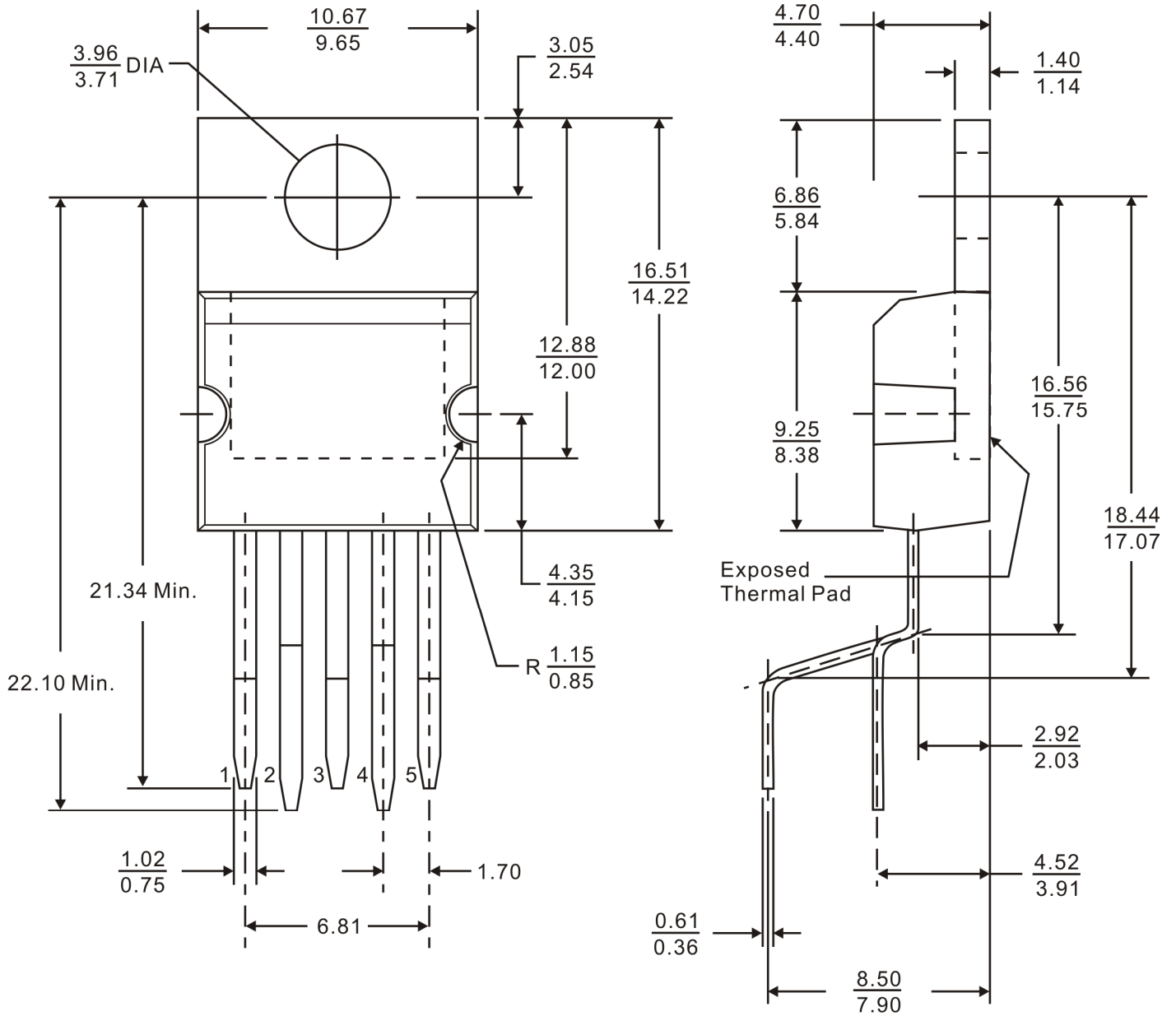

Note: All dimensions are in millimeter.

**IMPORTANT NOTICE**

Princeton Technology Corporation (PTC) reserves the right to make corrections, modifications, enhancements, improvements, and other changes to its products and to discontinue any product without notice at any time.

PTC cannot assume responsibility for use of any circuitry other than circuitry entirely embodied in a PTC product. No circuit patent licenses are implied.

Princeton Technology Corp.  
2F, 233-1, Baociao Road,  
Sindian Dist., New Taipei City 23145, Taiwan  
Tel: 886-2-66296288  
Fax: 886-2-29174598  
<http://www.princeton.com.tw>