

DESCRIPTION

The RS7805 and RS7812 can provide local on-card regulation, eliminating the distribution problems associated with single point regulation. Each employs internal current limiting, thermal shut-down and safe operating area protection, making it essentially indestructible. If adequate heat sinking is provided, they can deliver over 1A output current. Although designed primarily as fixed voltage regulators, these devices can be used with external components to obtain adjustable voltages and currents.

FEATURES

- Output current in excess of 1A
- Output voltages of 5V, 12V
- Internal short-circuit current limiting & thermal overload protection
- Guaranteed in extended temperature range

APPLICATIONS

- SCSI-2 active termination
- High efficiency linear regulators
- 5V to 3.3V voltage converter
- Battery charger
- Battery management circuits for notebook and palmtop PCs
- Core voltage supply: FPGA, PLD, DSP, CPU

SCHEMATIC DIAGRAM

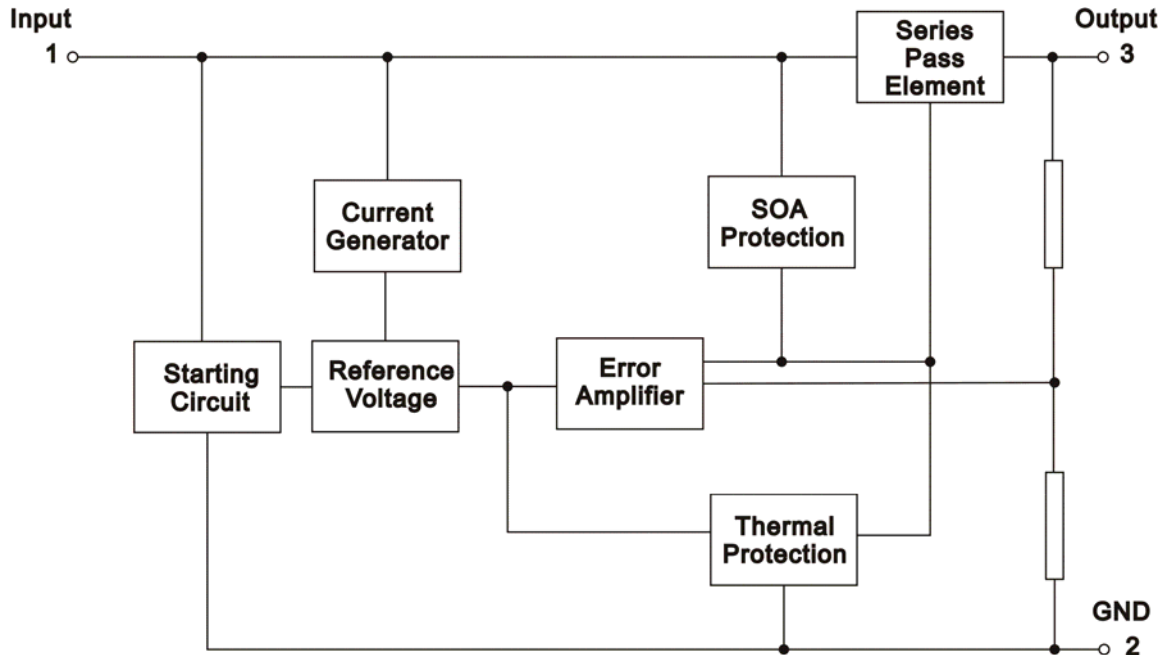

APPLICATION CIRCUITS

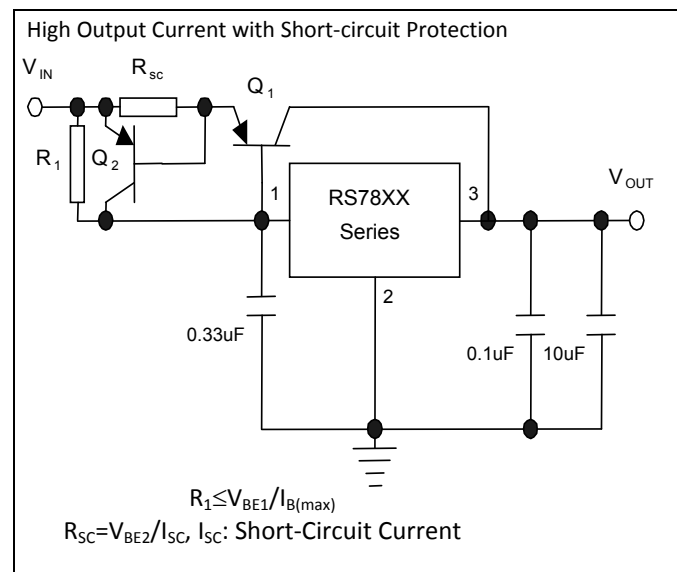
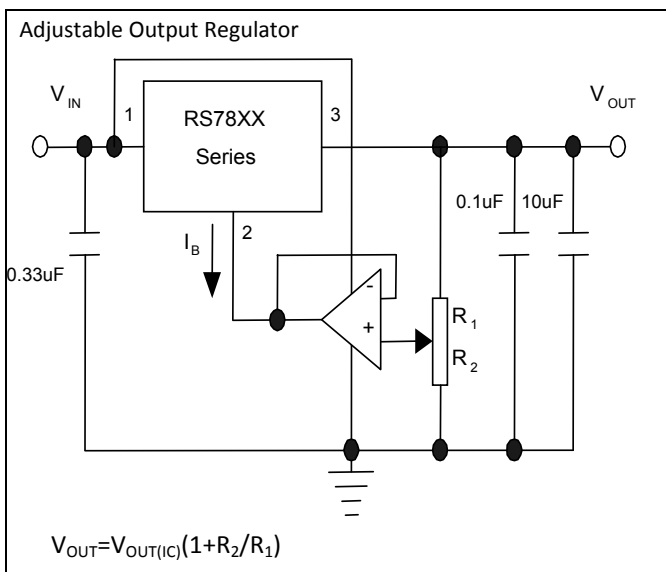
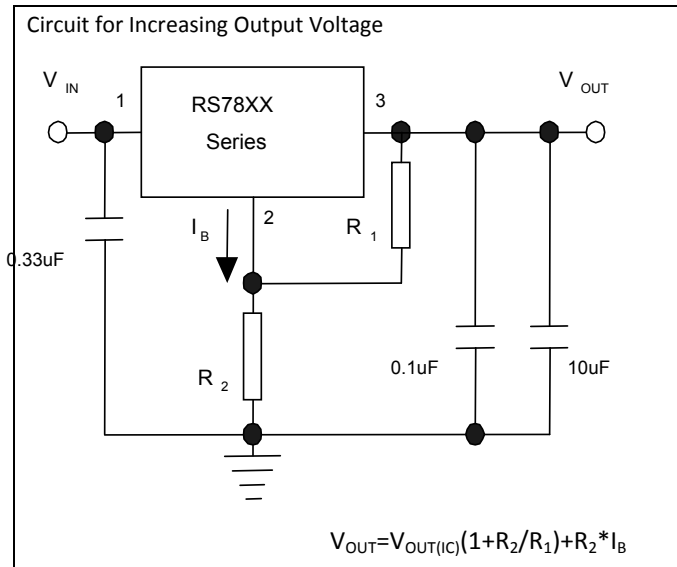
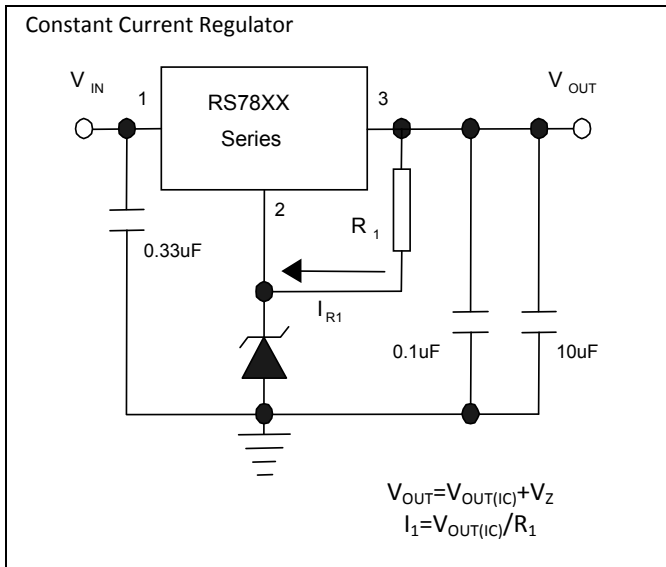

ORDER INFORMATION

Part Number	V _{OUT}	Package
RS7805E	5V±0.15V	TO-220AB
RS7812E	12V±0.36V	

PIN ASSIGNMENTS

TO-220-3

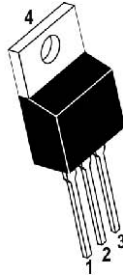

PIN DESCRIPTION

Package	Pin No.	Pin Name	Description
TO-220-3	1	VIN	Regulator Input Pin
	2, 4	GND	Ground Pin
	3	VOUT	Regulator Output Pin

ABSOLUTE MAXIMUM RATINGS

Parameter	Symbol	Maximum	Unit
Input Voltage	V_{IN}	40	V
Power Dissipation	P_D	Internally limited ^(Note)	W
Operating Temperature	T_{OPR}	0 to 125	°C
Storage Temperature	T_{STG}	-40 to 150	°C
Junction Temperature	T_J	150	°C

Note:
 $T_A=25^{\circ}\text{C}$, TO-220AB: 2.7W

THERMAL DATA

Characteristic	Symbol	TO-220AB	Unit
Thermal Resistance Junction-Case	$R_{th(i-c)}$	12.5	°C/W
Thermal Resistance Junction-Ambient	$R_{th(i-a)}$	47	°C/W

RS7805 SERIES ELECTRICAL CHARACTERISTICS

$V_{IN}=10V$, $I_{OUT}=500mA$, $C_{IN}=0.33\mu F$, $C_{OUT}=0.1\mu F$, $0^{\circ}C \leq T_J \leq 125^{\circ}C$ (unless otherwise specified)

Parameter	Symbol	Conditions	RS7805E			Units
			Min.	Typ.	Max.	
Output Voltage	V_O	$T_J=25^{\circ}C$, $I_{OUT}=500mA$	4.85	5	5.15	V
		$5mA \leq I_{OUT} \leq 1A$	4.85	5	5.15	
		$7V \leq V_{IN} \leq 25V$, $P_{OUT} \leq 15W$				
Line Regulation	ΔV_O	$T_J=25^{\circ}C$, $7V \leq V_{IN} \leq 25V$	-	3	50	mV
		$T_J=25^{\circ}C$, $8V \leq V_{IN} \leq 12V$	-	1	25	
Load Regulation	ΔV_O	$T_J=25^{\circ}C$, $5mA \leq I_{OUT} \leq 1A$	-	15	100	mV
		$T_J=25^{\circ}C$, $250mA \leq I_{OUT} \leq 750mA$	-	5	50	
Quiescent Current	I_B	$I_{OUT}=5mA$, $T_J=25^{\circ}C$	-	3.9	8	mA
Quiescent Current Change	ΔI_B	$I_{OUT}=500mA$, $7V \leq V_{IN} \leq 25V$, $T_J=25^{\circ}C$	-	-	1.3	mA
		$5mA \leq I_{OUT} \leq 1A$, $V_{IN}=10V$, $T_J=25^{\circ}C$	-	-	0.5	
Output Noise Voltage	eN	$B=10Hz \sim 100KHz$, $I_{OUT}=50mA$, $T_J=25^{\circ}C$	-	50	-	$\mu V/V_O$
Ripple Rejection	RR	$10V \leq V_{IN} \leq 18V$, $f=120Hz$, $I_{OUT}=50mA$, $T_J=25^{\circ}C$	57	73	-	dB
Dropout Voltage	V_D	$T_J=25^{\circ}C$, $I_{OUT}=1A$	-	2	2.5	V
Output Resistance	R_O	$f=1KHz$	-	17	-	$m\Omega$
Short Circuit Current	I_{SC}	$T_J=25^{\circ}C$	-	2.3	2.8	A
Output Voltage Drift	$\Delta V_O/\Delta T$	$0^{\circ}C \leq T_J \leq 125^{\circ}C$	-	-	0.6	$mV/^{\circ}C$

RS7812 SERIES ELECTRICAL CHARACTERISTICS

$V_{IN}=19V$, $I_{OUT}=500mA$, $C_{IN}=0.33\mu F$, $C_{OUT}=0.1\mu F$, $0^{\circ}C \leq T_J \leq 125^{\circ}C$ (unless otherwise specified)

Parameter	Symbol	Conditions	RS7812E			Units
			Min.	Typ.	Max.	
Output Voltage	V_O	$T_J=25^{\circ}C$, $I_{OUT}=500mA$	11.64	12	12.36	V
		$5mA \leq I_{OUT} \leq 1A$	11.64	12	12.36	
		$14V \leq V_{IN} \leq 30V$, $P_{OUT} \leq 15W$				
Line Regulation	ΔV_O	$T_J=25^{\circ}C$, $14.5V \leq V_{IN} \leq 30V$	-	10	120	mV
		$T_J=25^{\circ}C$, $16V \leq V_{IN} \leq 22V$	-	3	60	
Load Regulation	ΔV_O	$T_J=25^{\circ}C$, $5mA \leq I_{OUT} \leq 1A$	-	12	100	mV
		$T_J=25^{\circ}C$, $250mA \leq I_{OUT} \leq 750mA$	-	4	60	
Quiescent Current	I_B	$I_{OUT}=5mA$, $T_J=25^{\circ}C$	-	3.9	8	mA
Quiescent Current Change	ΔI_B	$I_{OUT}=500mA$, $14.5V \leq V_{IN} \leq 30V$, $T_J=25^{\circ}C$	-	-	1.3	mA
		$5mA \leq I_{OUT} \leq 1A$, $V_{IN}=19V$, $T_J=25^{\circ}C$	-	-	0.5	
Output Noise Voltage	eN	$B=10Hz \sim 100KHz$, $I_{OUT}=50mA$, $T_J=25^{\circ}C$	-	-	90	$\mu V/V_O$
Ripple Rejection	RR	$19V \leq V_{IN} \leq 25V$, $f=120Hz$, $I_{OUT}=50mA$, $T_J=25^{\circ}C$	50	66	-	dB
Dropout Voltage	V_D	$T_J=25^{\circ}C$, $I_{OUT}=1A$	-	2	2.5	V
Output Resistance	R_O	$f=1KHz$	-	18	-	$m\Omega$
Short Circuit Current	I_{SC}	$T_J=25^{\circ}C$	-	2.3	2.8	A
Output Voltage Drift	$\Delta V_O/\Delta T$	$0^{\circ}C \leq T_J \leq 125^{\circ}C$	-	-	1.6	$mV/^{\circ}C$

CHARACTERISTICS CURVE

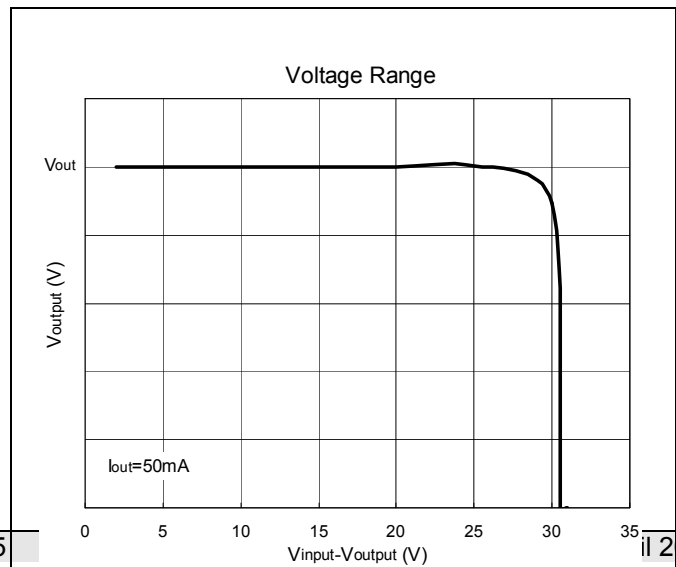
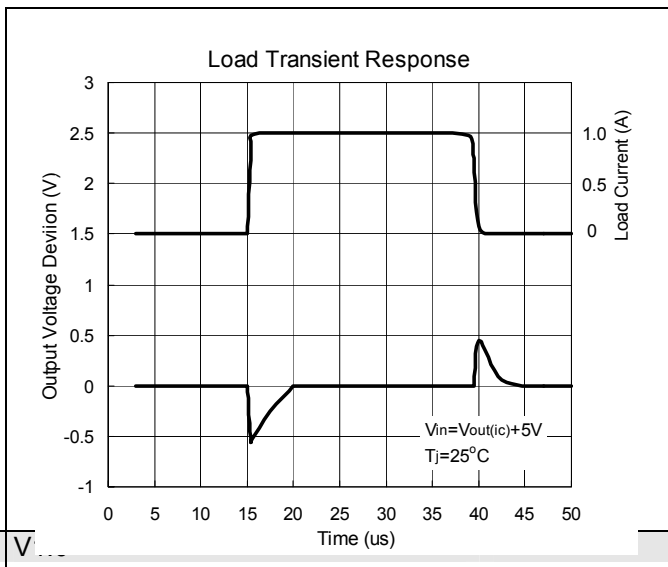
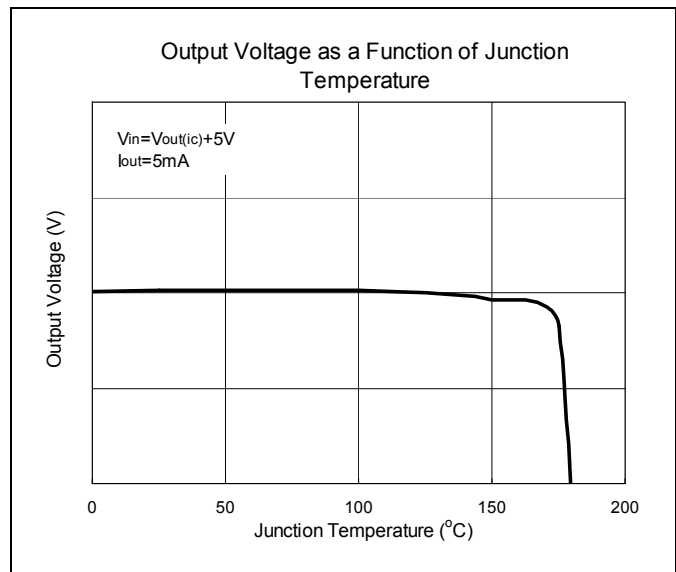
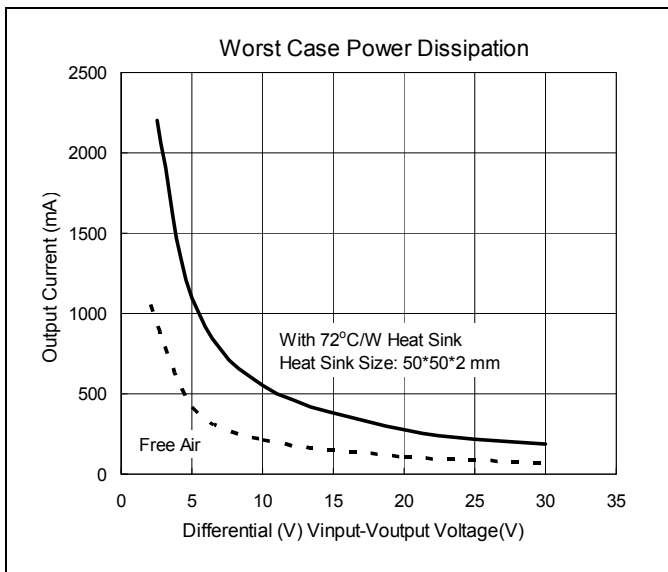
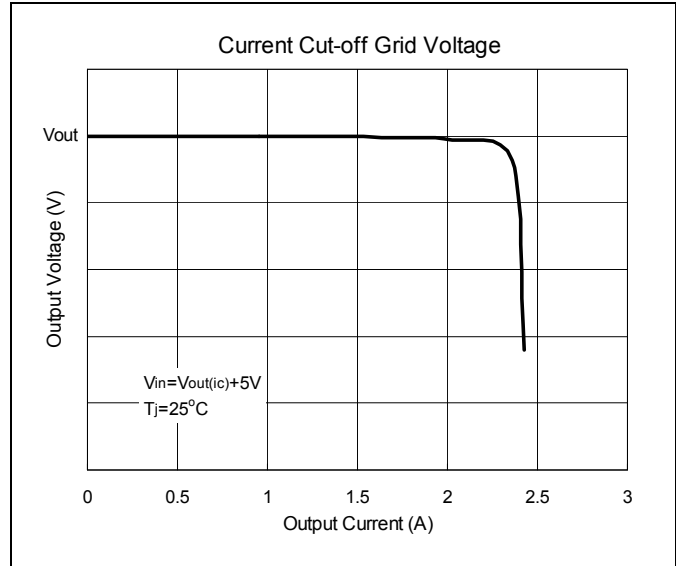
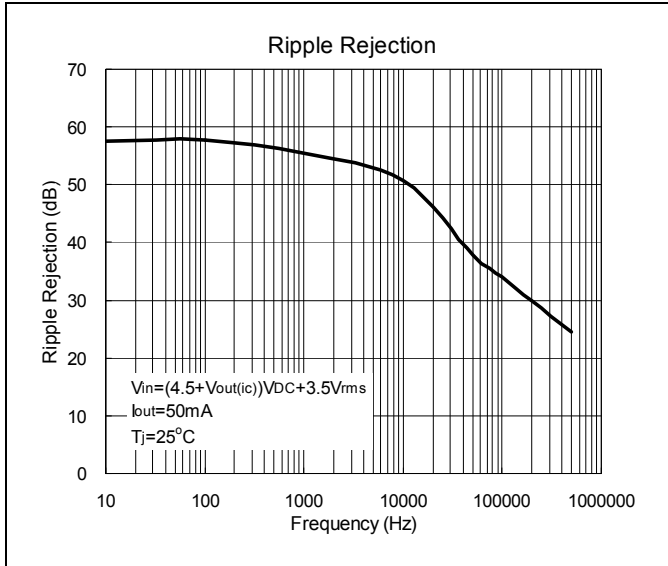

PACKAGE INFORMATION

TO-220-3

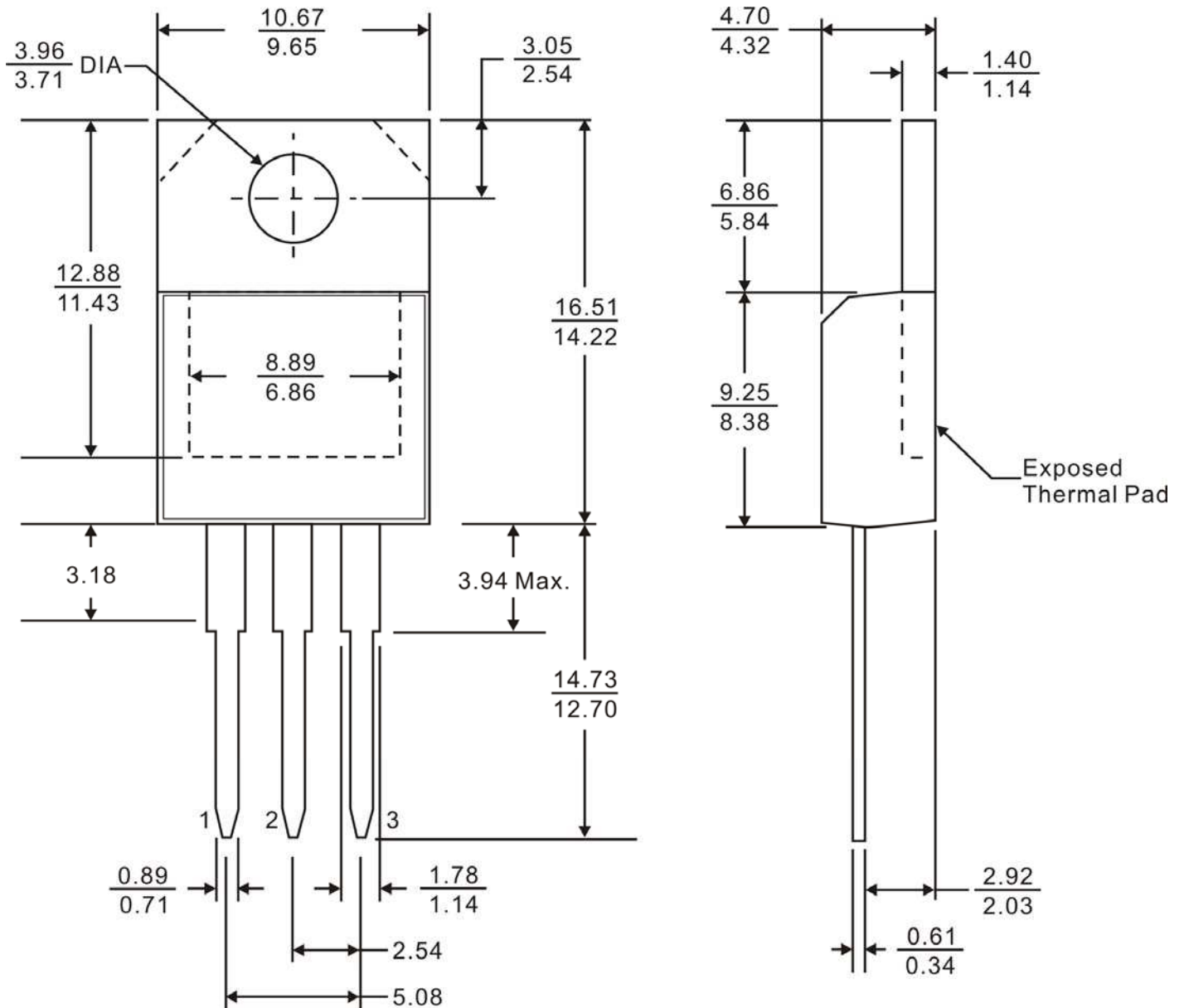

Notes:
 1. Refer to JEDEC TO-220 AB.
 2. All dimensions are in millimeter.

IMPORTANT NOTICE

Princeton Technology Corporation (PTC) reserves the right to make corrections, modifications, enhancements, improvements, and other changes to its products and to discontinue any product without notice at any time.

PTC cannot assume responsibility for use of any circuitry other than circuitry entirely embodied in a PTC product. No circuit patent licenses are implied.

Princeton Technology Corp.
2F, 233-1, Baociao Road,
Sindian Dist., New Taipei City 23145, Taiwan
Tel: 886-2-66296288
Fax: 886-2-29174598
<http://www.princeton.com.tw>