

DESCRIPTION

The RS1117A is a 1A low-dropout positive voltage regulator. It is available in fixed and adjustable output voltage versions. Over current and thermal protection are integrated onto the chip. Output current will limit as while it reaches the pre- set current or temperature limit. The dropout voltage is specified at 1.40V Maximum at full rated output current. The RS1117A series provides excellent regulation over line, load and temperature variations.

FEATURES

- Low Dropout Voltage 1.40V (Max.) at 1.0A
- Adjustable or Fixed Voltage (1.8V, 2.5V, 3.3V, 5.0V)
- Over Current Protection
- Thermal Overload Protection
- Maximum Line Regulation 0.2%
- Maximum Load Regulation 1.0%
- Adjust Pin Current Less Than 120 μ A

APPLICATIONS

- SCSI-2 Active Termination
- High Efficiency Linear Regulators
- 5V to 3.3V Voltage Converter
- Battery Charger
- Battery Management Circuits for Notebook and Palmtop PCs
- Core Voltage Supply: FPGA, PLD, DSP, CPU

APPLICATION CIRCUIT

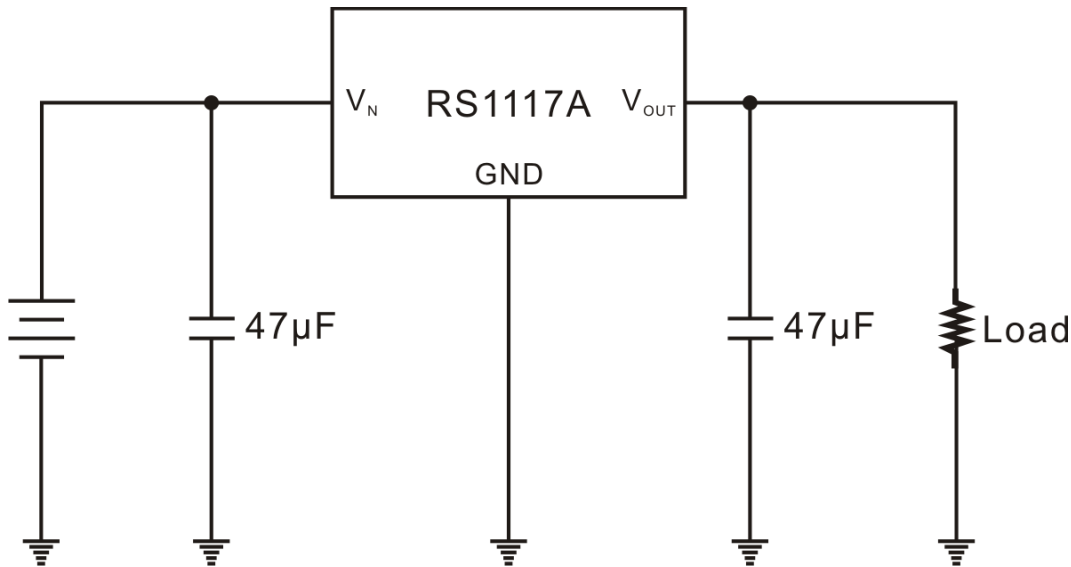

ORDER INFORMATION

Device	Device Code
RS1117A-XX YY Z	<p>XX is package designator: M: SOT-89 SJ: SOT-223 J: TO-252</p> <p>YY is nominal output voltage designator: AD: ADJ 18: 1.8V 25: 2.5V 33: 3.3V 50: 5.0V</p> <p>Z is Lead Free designator: P: Commercial Standard, Lead (Pb) Free and Phosphorous (P) Free Package G: Green (Halogen Free with Commercial Standard)</p>

PIN ASSIGNMENTS

SOT-89

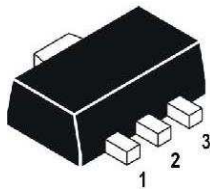

SOT-223

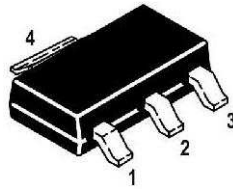

TO-252

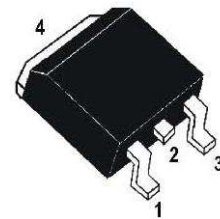

PIN DESCRIPTION

Package	Pin No.	Pin Name	Description
SOT-89	1	ADJ/GND	Ground Pin or ADJ Terminal Pin for Adjustable.
	2	VOUT	Regulator Output Pin
	3	VIN	Regulator Input Pin
SOT-223	1	ADJ/GND	Ground Pin or ADJ Terminal Pin for Adjustable.
	2, 4	VOUT	Regulator Output Pin
	3	VIN	Regulator Input Pin
TO-252	1	ADJ/GND	Ground Pin or ADJ Terminal Pin for Adjustable.
	2, 4	VOUT	Regulator Output Pin
	3	VIN	Regulator Input Pin

FUNCTION DESCRIPTION

OUTPUT VOLTAGE ADJUSTMENT

Like most regulators, RS1117A series regulate the output by comparing the output voltage to an internally generated reference voltage. On the adjustable version, the V_{REF} is available externally as 1.25V between V_{OUT} and ADJ. The voltage ratio formed by R_1 and R_2 should be set to conduct 10mA (minimum output load). The output voltage is given by the following equation: $V_{OUT} = V_{REF} (1 + R_2/R_1) + I_{ADJ} R_2$

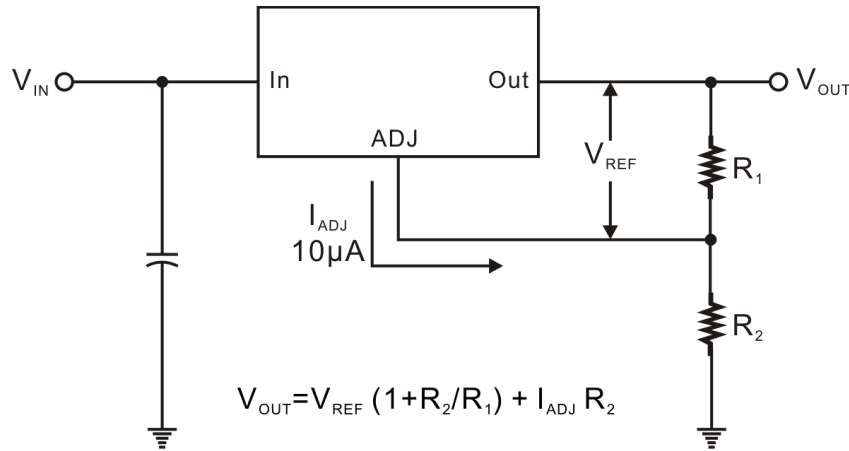

Figure 1

On fixed versions of RS1117A series, the voltage divider is provided internally.

THERMAL PROTECTION

RS1117A series have thermal protection which limits junction temperature to 150°C. However, device functionality is only guaranteed to a maximum junction temperature of +125°C.

The power dissipation and junction temperature for RS1117A in all packages given by $P_D = (V_{IN} - V_{OUT}) I_{OUT}$,

$T_{JUNCTION} = T_{AMBIENT} + (P_D \times \theta_{JA})$, Note: $T_{JUNCTION}$ must not exceed 125°C.

CURRENT LIMIT PROTECTION

RS1117A series are protected against overload conditions. Current protection is triggered at typically 1.5A.

STABILITY AND LOAD REGULATION

RS1117A series require a capacitor from V_{OUT} to GND to provide compensation feedback to the internal gain stage. This is to ensure stability at the output terminal. Typically, a 47µF tantalum or 100µF aluminum electrolytic is sufficient.

Note: It is important that the ESR for this capacitor does not exceed 0.5Ω.

The output capacitor does not have a theoretical upper limit and increasing its value will increase stability. $C_{OUT} = 100\mu F$ or more is typical for high current regulator design.

RS1117A series load regulation are limited by the resistance of the wire connecting it to the load (R_P). For the adjustable version, the best load regulation is accomplished when the top of the resistor divider (R_1) is connected directly to the output pin of the RS1117A series. When so connected, R_P is not multiplied by the divider ratio. For fixed output versions, the top of R_1 is internally connected to the output and ground pin can be connected to low side of the load as a negative side sense if, so desired.

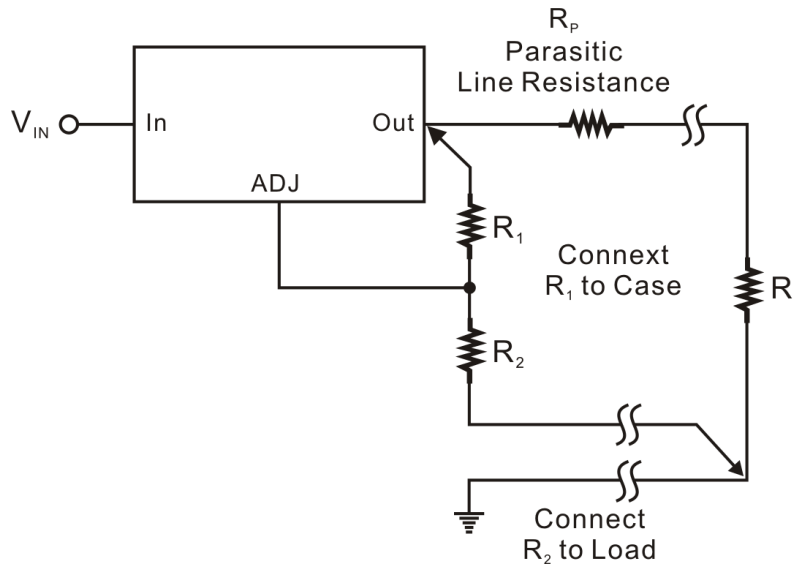

Figure 2

THERMAL CONSIDERATION

The RS1117A series contain thermal limiting circuitry designed to protect itself for over-temperature conditions. Even for normal load conditions, maximum junction temperature ratings must not be exceeded. As mention in thermal protection section, we need to consider all sources of thermal resistance between junction and ambient. It contains junction-to-case, case-to-heat-sink interface and heat sink resistance itself. An additional heat sink is applied externally sometimes. It can increase the maximum power dissipation. For example, the equivalent junction temperature of 300mA output current is 115°C without external heat sink. Under the same junction temperature IC can operates 500mA with an adequate heat sink.

Therefore, to attach an extra heat sink is recommended.

Junction-to-case thermal resistance is specified from the IC junction to the bottom of the case directly below the die. The bonding wires are appending paths. The former is the lowest resistance path. Proper mounting is required to ensure the best possible thermal flow this area of the package to the heat sink. Thermal compound at the case-to-heat-sink interface is strongly recommended. The case of all devices in this series is electrically connected to the output. Therefore, if the case of the device must be electrically isolated, a thermally conductive spacer can be used, as long its thermal resistance is considered.

PROTECTION DIODE

(The figure is shown as Regulator with Reverse Diode Protection in advanced applications)

In general operation, RS1117A series don't need any protection diodes. From the cross-section structure of RS1117A series, the output pin is connected to P+ substrate, and the input pin is connected to N-well. There is a parasitic reverse diode between them. It can handle microsecond surge currents of 5A to 10A. Even with large output capacitance, it is very difficult to get those values of surge currents in normal operation. Only with high value output capacitors, such as 1000 μ F. And with the input pin instantaneously shorted to ground, can damage occur. A crowbar circuit at the input of the RS1117A series can generate those kinds of currents, and a diode from output to input is recommended. Normal power supply cycling or even plugging and unplugging in the system will not generate currents large enough to do any damage.

ABSOLUTE MAXIMUM RATINGS

Parameter	Symbol	Ratings	Unit
Input voltage	V_{IN}	15	V
Power dissipation	P_D	Internally Limited (see Note)	W
Operating junction temperature range	T_{OPR}	-20 to +125	°C
Storage temperature range	T_{STG}	-40 to +150	°C
Lead temperature (Soldering) 5 sec	T_{LEAD}	260	°C
HBM (Human Body Mode)		2	KV/Min

Note: SOT-223: 0.9W(Max.), SOT-89: 0.6W(Max.), TO-252: 0.9W(Max.), TO-220: 2.1W(Max.)

ELECTRICAL CHARACTERISTICS

($T_A=25^\circ\text{C}$, unless otherwise specified)

RS1117A-18 (1.8V)

Parameter	Symbol	Test Conditions	Min.	Typ.	Max.	Units	
Output voltage	V_{OUT}	$V_{IN}=5V, I_O=0A$	$T_J=0^\circ\text{C}$ to 125°C	1.764	1.800	1.836	V
Line regulation	REG_{LINE}	$V_{IN}=4.75V$ to $7V, I_O=0A$	$T_J=0^\circ\text{C}$ to 125°C	-	-	0.2	%
Load regulation	REG_{LOAD}	$V_{IN}=5V, I_O=0A$ to $1A$	$T_J=0^\circ\text{C}$ to 125°C	-	0.1	1.0	
Dropout voltage	$V_{DROPOUT}$	$\Delta V_O=\pm 1\%, I_O=0A$ to $1A$	$T_J=0^\circ\text{C}$ to 125°C	-	1.2	1.40	V
Current limit	I_S	$V_{IN}=4.75V$ to $7V$	$T_J=0^\circ\text{C}$ to 125°C	1.0	1.5	-	A
Quiescent current	I_Q	$V_{IN}=5V, I_O=0A$ to $1A$	$T_J=0^\circ\text{C}$ to 125°C	-	6.0	13	mA
Temp. coefficient	T_C	$V_{IN}=4.75V$ to $7V, I_O=0A$ to $1A$		-	0.005	-	%/°C
Temp. stability	T_S	$V_{IN}=5V, I_O=100mA$	$T_J=0^\circ\text{C}$ to 125°C	-	0.5	-	%
RMS output noise	V_N	$10\text{Hz} \leq f \leq 10\text{KHz}$	$T_J=25^\circ\text{C}$	-	0.003	-	% ΔV_O
Ripple rejection ratio	R_A	$V_{IN}=5V, I_O=1A$	$T_J=0^\circ\text{C}$ to 125°C	60	72	-	dB

RS1117A-50 (5.0V)

Parameter	Symbol	Test Conditions	Min.	Typ.	Max.	Units	
Output voltage	V_{OUT}	$V_{IN}=7V, I_O=0A$	$T_J=0^\circ\text{C}$ to 125°C	4.900	5.000	5.100	V
Line regulation	REG_{LINE}	$V_{IN}=7V$ to $9V, I_O=0A$	$T_J=0^\circ\text{C}$ to 125°C	-	-	0.2	%
Load regulation	REG_{LOAD}	$V_{IN}=7V, I_O=0A$ to $1A$	$T_J=0^\circ\text{C}$ to 125°C	-	0.1	1.0	
Dropout voltage	$V_{DROPOUT}$	$\Delta V_O=\pm 1\%, I_O=0A$ to $1A$	$T_J=0^\circ\text{C}$ to 125°C	-	1.2	1.40	V
Current limit	I_S	$V_{IN}=7V$ to $10V$	$T_J=0^\circ\text{C}$ to 125°C	1.0	1.5	-	A
Quiescent current	I_Q	$V_{IN}=7V, I_O=0A$ to $1A$	$T_J=0^\circ\text{C}$ to 125°C	-	6.0	13	mA
Temp. coefficient	T_C	$V_{IN}=7V$ to $10V, I_O=0A$ to $1A$		-	0.005	-	%/°C
Temp. stability	T_S	$V_{IN}=5V, I_O=100mA$	$T_J=0^\circ\text{C}$ to 125°C	-	0.5	-	%
RMS output noise	V_N	$10\text{Hz} \leq f \leq 10\text{KHz}$	$T_J=25^\circ\text{C}$	-	0.003	-	% ΔV_O
Ripple rejection ratio	R_A	$V_{IN}=5V, I_O=1A$	$T_J=0^\circ\text{C}$ to 125°C	60	72	-	dB

RS1117A-33 (3.3V)

Parameter	Symbol	Test Conditions		Min.	Typ.	Max.	Units
Output voltage	V_{OUT}	$V_{IN}=5V, I_O=0A$	$T_J=0^{\circ}C$ to $125^{\circ}C$	3.234	3.300	3.370	V
Line regulation	REG_{LINE}	$V_{IN}=4.75V$ to $7V, I_O=0A$	$T_J=0^{\circ}C$ to $125^{\circ}C$	-	-	0.2	%
Load regulation	REG_{LOAD}	$V_{IN}=5V, I_O=0A$ to $1A$	$T_J=0^{\circ}C$ to $125^{\circ}C$	-	0.1	1.0	
Dropout voltage	$V_{DROPOUT}$	$\Delta V_O=\pm 1\%, I_O=0A$ to $1A$	$T_J=0^{\circ}C$ to $125^{\circ}C$	-	1.2	1.40	V
Current limit	I_S	$V_{IN}=4.75V$ to $7V$	$T_J=0^{\circ}C$ to $125^{\circ}C$	1.0	1.5	-	A
Quiescent current	I_Q	$V_{IN}=5V, I_O=0A$ to $1A$	$T_J=0^{\circ}C$ to $125^{\circ}C$	-	6.0	13	mA
Temp. coefficient	T_C	$V_{IN}=4.75V$ to $7V, I_O=0A$ to $1A$		-	0.005	-	%/ $^{\circ}C$
Temp. stability	T_S	$V_{IN}=5V, I_O=100mA$	$T_J=0^{\circ}C$ to $125^{\circ}C$	-	0.5	-	%
RMS output noise	V_N	$10Hz \leq f \leq 10KHz$	$T_J=25^{\circ}C$	-	0.003	-	% ΔV_O
Ripple rejection ratio	R_A	$V_{IN}=5V, I_O=1A$	$T_J=0^{\circ}C$ to $125^{\circ}C$	60	72	-	dB

RS1117A-25 (2.5V)

Parameter	Symbol	Test Conditions		Min.	Typ.	Max.	Units
Output voltage	V_{OUT}	$V_{IN}=5V, I_O=0A$	$T_J=0^{\circ}C$ to $125^{\circ}C$	2.450	2.500	2.550	V
Line regulation	REG_{LINE}	$V_{IN}=4.75V$ to $7V, I_O=0A$	$T_J=0^{\circ}C$ to $125^{\circ}C$	-	-	0.2	%
Load regulation	REG_{LOAD}	$V_{IN}=5V, I_O=0A$ to $1A$	$T_J=0^{\circ}C$ to $125^{\circ}C$	-	0.1	1.0	
Dropout voltage	$V_{DROPOUT}$	$\Delta V_O=\pm 1\%, I_O=0A$ to $1A$	$T_J=0^{\circ}C$ to $125^{\circ}C$	-	1.2	1.40	V
Current limit	I_S	$V_{IN}=4.75V$ to $7V$	$T_J=0^{\circ}C$ to $125^{\circ}C$	1.0	1.5	-	A
Quiescent current	I_Q	$V_{IN}=5V, I_O=0A$ to $1A$	$T_J=0^{\circ}C$ to $125^{\circ}C$	-	6.0	13	mA
Temp. coefficient	T_C	$V_{IN}=4.75V$ to $7V, I_O=0A$ to $1A$		-	0.005	-	%/ $^{\circ}C$
Temp. stability	T_S	$V_{IN}=5V, I_O=100mA$	$T_J=0^{\circ}C$ to $125^{\circ}C$	-	0.5	-	%
RMS output noise	V_N	$10Hz \leq f \leq 10KHz$	$T_J=25^{\circ}C$	-	0.003	-	% ΔV_O
Ripple rejection ratio	R_A	$V_{IN}=5V, I_O=1A$	$T_J=0^{\circ}C$ to $125^{\circ}C$	60	72	-	dB

RS1117A-AD (ADJ)

Parameter	Symbol	Test Conditions		Min.	Typ.	Max.	Units
Reference voltage	V_{REF}	$V_{IN}=5V, I_O=10mA$	$T_J=0^{\circ}C$ to $125^{\circ}C$	1.225	1.250	1.275	V
Line regulation	REG_{LINE}	$V_{IN}=4.75V$ to $7V, I_O=10mA$	$T_J=0^{\circ}C$ to $125^{\circ}C$	-	-	0.2	%
Load regulation	REG_{LOAD}	$V_{IN}=5V, I_O=10mA$ to $1A$	$T_J=0^{\circ}C$ to $125^{\circ}C$	-	0.1	1.0	
Dropout voltage	$V_{DROPOUT}$	$\Delta V_O=\pm 1\%, I_O=10mA$ to $1A$	$T_J=0^{\circ}C$ to $125^{\circ}C$	-	1.2	1.40	V
Current limit	I_S	$V_{IN}=2.7V$ to $7V$	$T_J=0^{\circ}C$ to $125^{\circ}C$	1.0	1.5	-	A
Temp. coefficient	T_C	$V_{IN}=2.75V$ to $7V, I_O=10mA$ to $1A$		-	0.005	-	%/ $^{\circ}C$
Adjust pin current	I_{ADJ}	$V_{IN}=2.75V$ to $7V, I_O=10mA$ to $1A$	$T_J=0^{\circ}C$ to $125^{\circ}C$	-	55	120	μA
Adjust pin current change	ΔI_{ADJ}	$V_{IN}=2.75V$ to $7V, I_O=10mA$ to $1A$	$T_J=0^{\circ}C$ to $125^{\circ}C$	-	0.2	5.0	
Temp. stability	T_S	$V_{IN}=5V, I_O=100mA$	$T_J=0^{\circ}C$ to $125^{\circ}C$	-	0.5	-	%
Minimum load current	I_O	$V_{IN}=5V$		-	5.0	10	mA
RMS output noise	V_N	$10Hz \leq f \leq 10KHz$	$T_J=25^{\circ}C$	-	0.003	-	% ΔV_O
Ripple rejection ratio	R_A	$V_{IN}=5V, I_O=1A$	$T_J=0^{\circ}C$ to $125^{\circ}C$	60	72	-	dB

CHARACTERISTICS CURVE

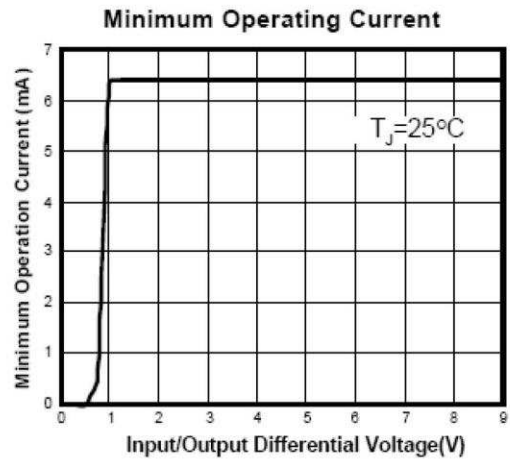
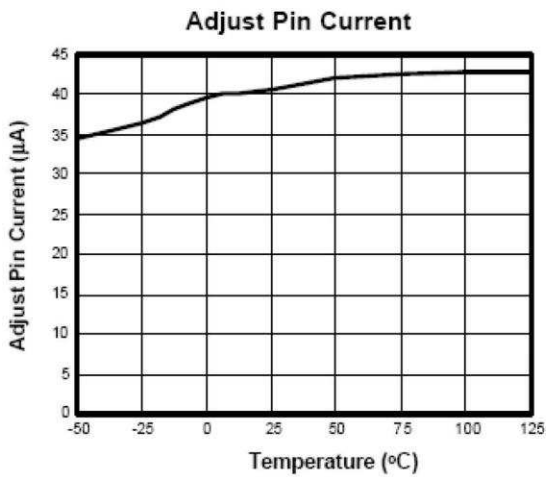
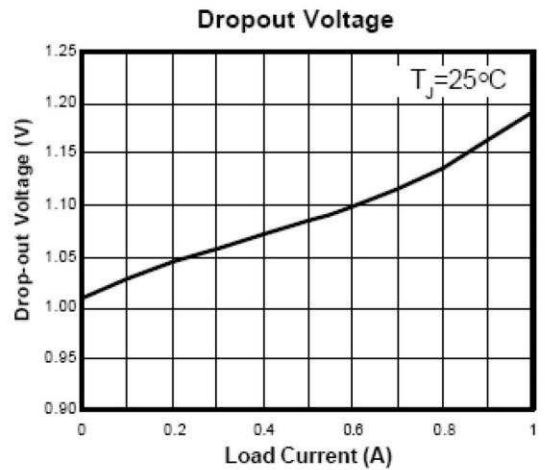
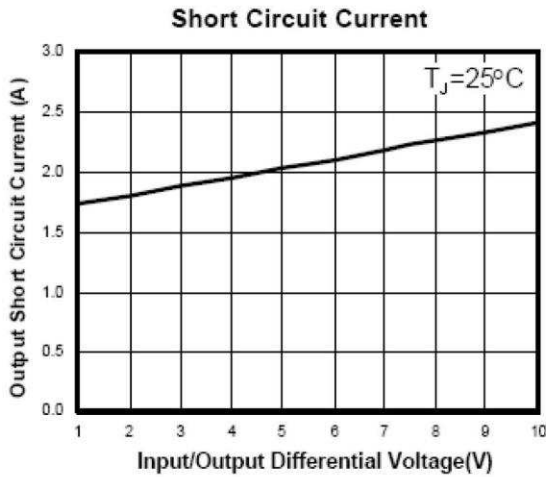
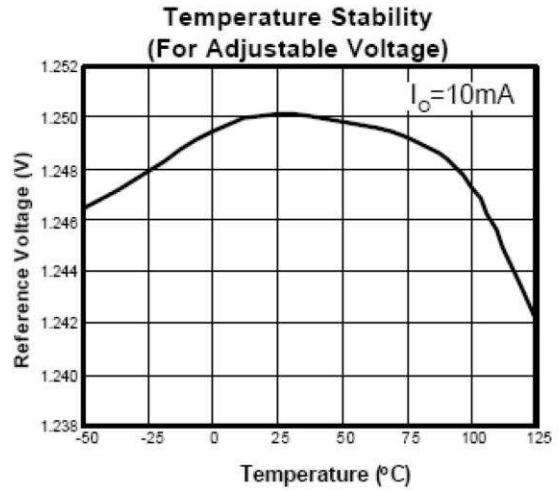
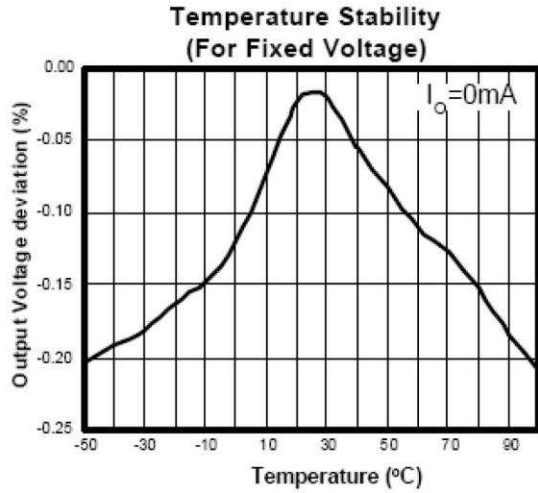

PACKAGE INFORMATION

SOT-89

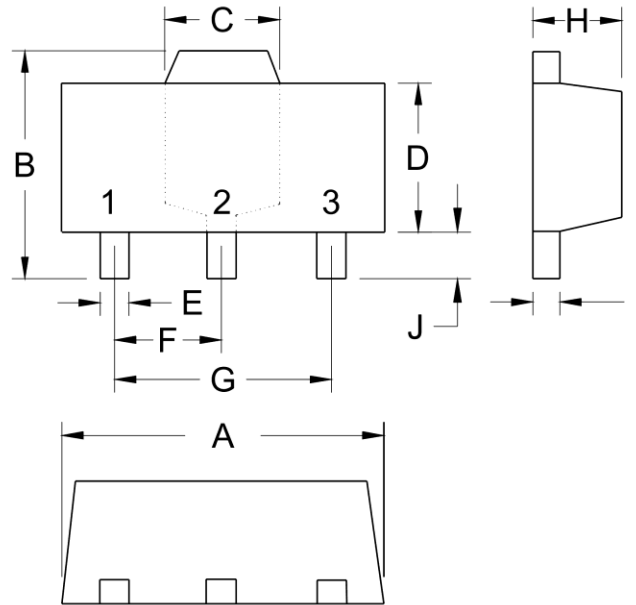

Symbol	Millimeter	
	Min.	Max.
A	4.40	4.60
B	4.05	4.25
C	1.50	1.70
D	2.40	2.60
E	0.36	0.51
F	*1.50	-
G	*3.00	-
H	1.40	1.60
I	0.35	0.41

Notes:

1. All dimensions are in millimeter.

TO-252

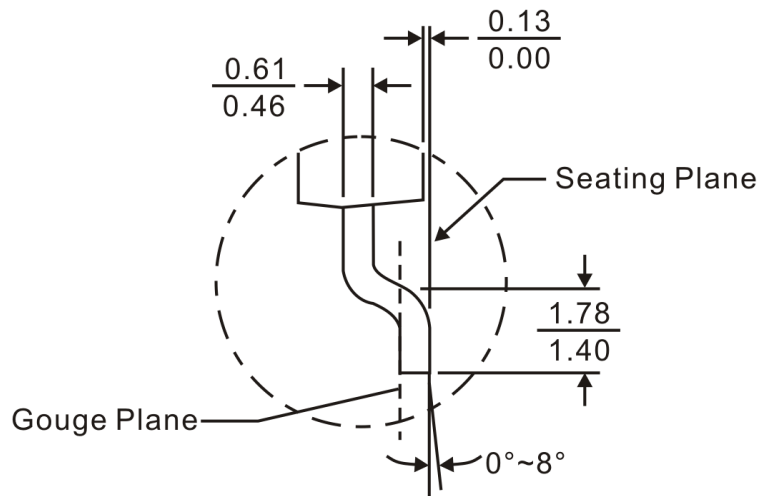
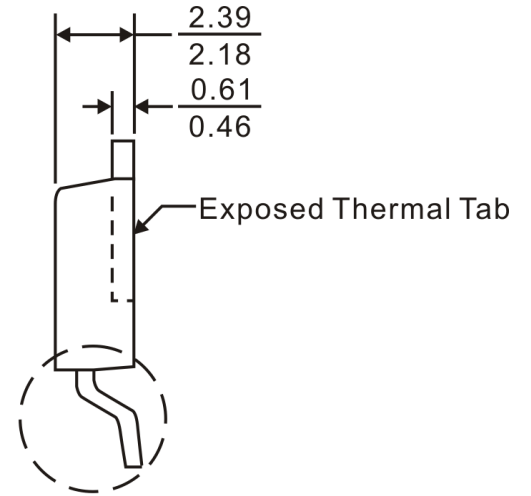
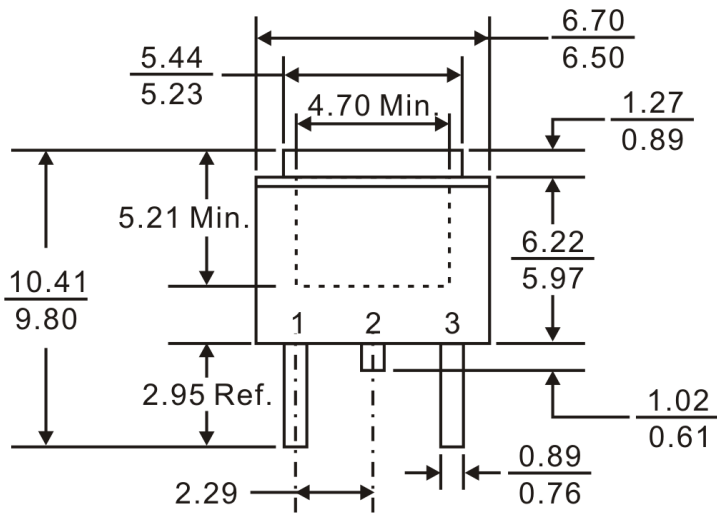

Notes:

1. Refer to JEDEC TO-252 AA.
2. All dimensions are in millimeter.

IMPORTANT NOTICE

Princeton Technology Corporation (PTC) reserves the right to make corrections, modifications, enhancements, improvements, and other changes to its products and to discontinue any product without notice at any time.

PTC cannot assume responsibility for use of any circuitry other than circuitry entirely embodied in a PTC product. No circuit patent licenses are implied.

Princeton Technology Corp.
2F, 233-1, Baociao Road,
Sindian Dist., New Taipei City 23145, Taiwan
Tel: 886-2-66296288
Fax: 886-2-29174598
<http://www.princeton.com.tw>

REVISION HISTORY

Date	Revision No.	Reference No.	Modification
12/28/2012	RS1117A V1.0	MAC1212016	1. Orister format modify to PTC format 2. P5, Absolute Maximum Rating, T _{OPR} , 0~+150→-20~+125; T _{STG} , -65~+150→-40~+150
11/27/2013	RS1117A V1.1	MAC1311008	Delete the package type TO-220-3