



DESCRIPTION

PT2264 is a remote control encoder paired with PT2294 utilizing CMOS Technology. It encodes data and address pins into a serial coded waveform suitable for RF modulation. PT2264 has a maximum of 12-bit of tri-state address pins providing up to 531,441 (or 3^{12}) address codes; thereby, drastically reducing any code collision and unauthorized code scanning possibilities.

FEATURES

- CMOS technology
- Low power consumption
- Very high noise immunity
- Up to 12 Tri-State code address pins
- Up to 4 data pins
- Wide range of operating voltage: VCC=8 ~ 15V
- Single resistor oscillator
- Latch or momentary output type
- Available in DIP and SOP package

APPLICATIONS

- Remote control fan
- Home security/Automation system
- Remote control toys
- Remote control for door bell



BLOCK DIAGRAM

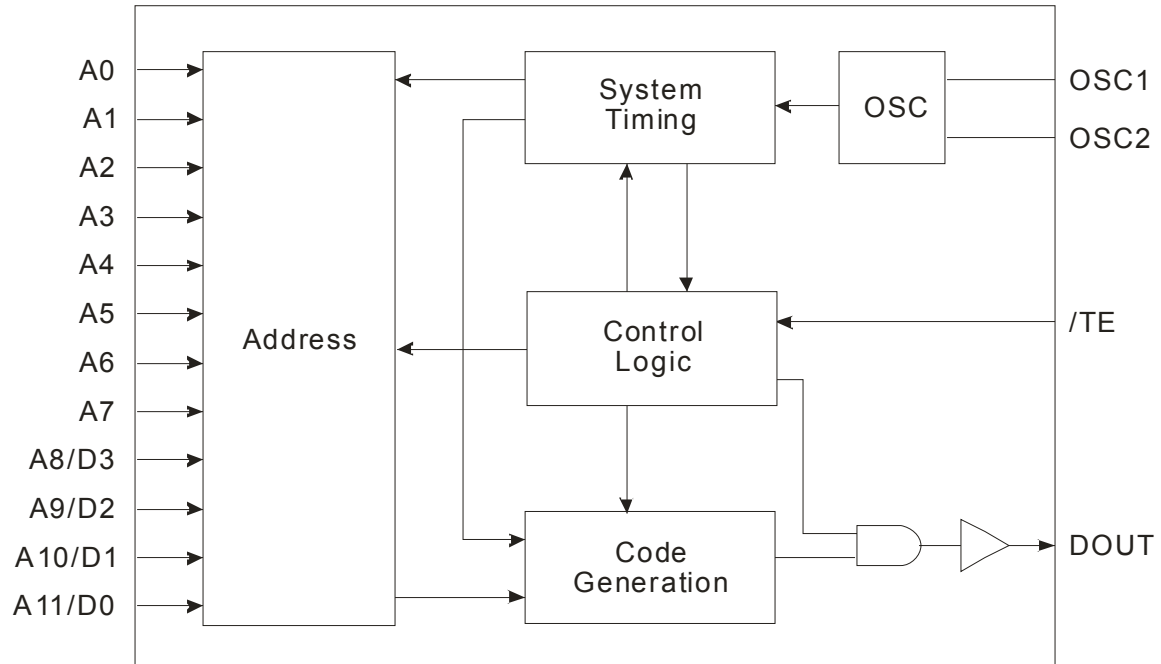



PIN CONFIGURATION

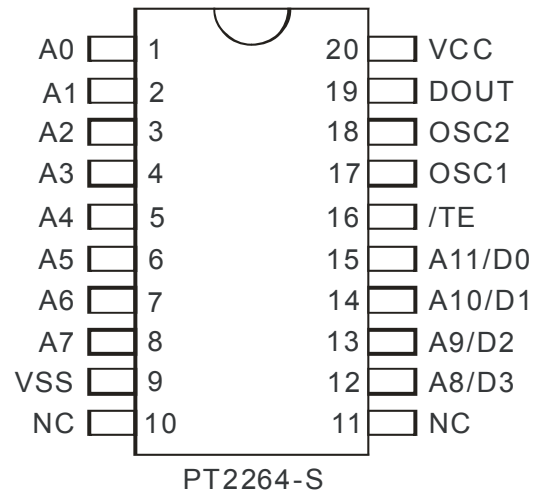
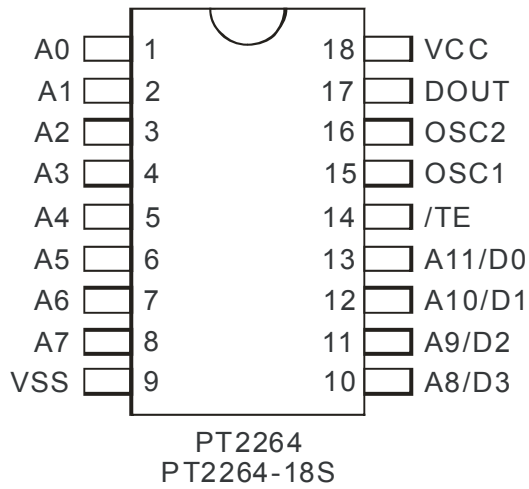



PIN DESCRIPTION

Pin Name	I/O	Description	Pin No.	
			18 Pins	20 Pins
A0 ~ A7	I	Code Address Pin No.0 ~ 7 These ten tri-state pins are detected by PT2264 to determine the encoded waveform bit 0 ~ bit 9. Each pin can be set to "0", "1" or "f" (floating).	1 ~ 8	1 ~ 8
A8/D3 ~ A11/D0	I	Code Address Pin Nos.8 ~ 11/Data Pin No.0 ~ 3. These four tri-state pins are detected by PT2264 to determine the encoded waveform bit 10, bit 11. When these pins are used as address pins, they can be set to "0", "1", or "f" (floating). When these pins are used as data pins, they can be set only to "0" or "1".	10 ~ 13	12 ~ 15
/TE	I	Transmission Enable. Active Low Signal. PT2264 outputs the encoded waveform to DOUT when this pin is pulled to low.	14	16
OSC1	O	Oscillator Pin No.1 A resistor connected between these two pins determine the fundamental frequency of the PT2264.	15	17
OSC2	I		Oscillator Pin No.2	16
DOUT	O	Data Output Pin. The encoded waveform is serially outputted to this pin. When PT2264 is not transmitting, DOUT outputs low (VSS) voltage.	17	19
VCC	-	Positive Power Supply	18	20
VSS	-	Negative Power Supply	9	9



FUNCTION DESCRIPTION

PT2264 encodes the code address and data set at A0 ~ A7 and A8/D3 ~ A11/D0 into a special waveform and outputs it to the DOUT when /TE is pulled to "0" (Low State). This waveform is fed to either the RF modulator for transmission. The transmitted radio frequency is received by the RF demodulator receiver and reshaped to the special waveform. PT2294 is then used to decode the waveform and set the corresponding output pin(s). Thus completing a remote control encoding and decoding function.

RF OPERATION

CODE BITS

A Code Bit is the basic component of the encoded waveform, and can be classified as either an AD (Address/Data) Bit or a SYNC (Synchronous) Bit.

Address/Data (AD) Bit Waveform

An AD Bit can be designated as Bit "0", "1" or "f" if it is in low, high or floating state respectively. One bit waveform consists of 2 pulse cycles. Each pulse cycle has 16 oscillating time periods. For further details, please refer to the diagram below:

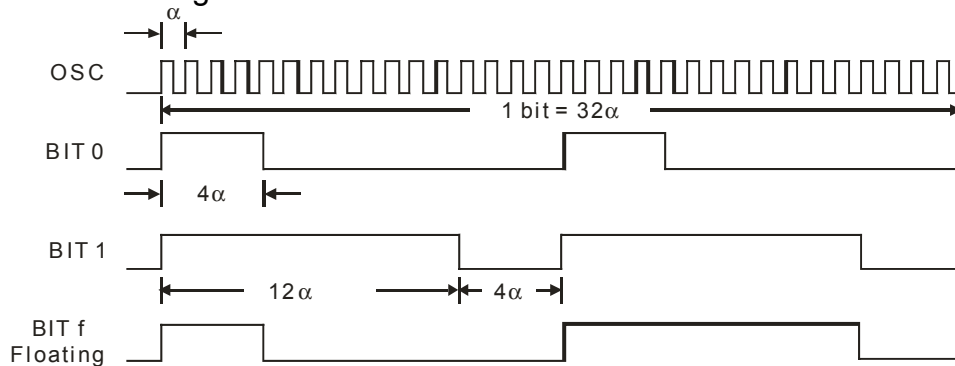

where: α =Oscillating Clock Period

Synchronous (Sync.) Bit Waveform

The Synchronous Bit Waveform is 4-bit long with 1/8 bit width pulse. Please refer to the diagram below:

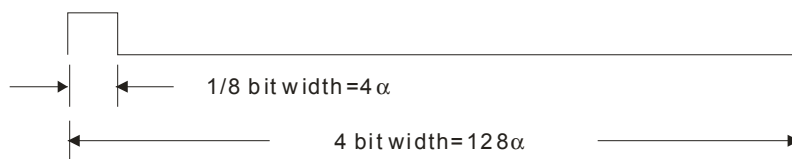

Note: 1-bit = 32α



Remote Control Encoder IC

PT2264

CODE WORD

A group of Code Bits is called a Code Word. A Code Word consists of 12 AD bits followed by one Sync Bit. The 12 AD bits are determined by the corresponding states of A0 ~ A7 and A8/D3 ~ A11/D0 pins at the time of transmission. When Data Type of PT2264 is used, the address bits will decrease accordingly.

For example: In the 4 Data Type where the address has eight (8) bits, the transmitting format is:



PT2264/PT2294 have a maximum of twelve (12) Address Bits, four (4) Address/Data bits. The following diagram shows the code bits with their corresponding pins.

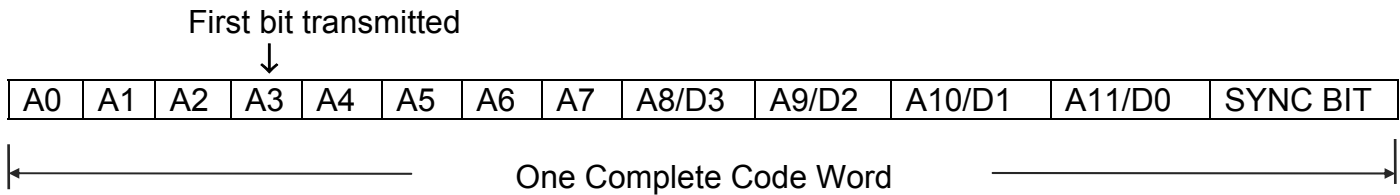

	A0	A1	A2	A3	A4	A5	A6	A7	A8	A9	A10	A11	Sync Bit
0 Data	A0	A1	A2	A3	A4	A5	A6	A7	A8	A9	A10	A11	Sync Bit
1 Data	A0	A1	A2	A3	A4	A5	A6	A7	A8	A9	A10	D0	Sync Bit
2 Data	A0	A1	A2	A3	A4	A5	A6	A7	A8	A9	D1	D0	Sync Bit
3 Data	A0	A1	A2	A3	A4	A5	A6	A7	A8	D2	D1	D0	Sync Bit
4 Data	A0	A1	A2	A3	A4	A5	A6	A7	D3	D2	D1	D0	Sync Bit

The Code Bits A0 ~ A7 and A8/D3 ~ A11/D0 are determined by the states of A0 ~ A7 and A8/D3 ~ A11/D0 pins. For example, when the A0 (Pin No. 1) is set to "1" (VCC), the Code Bit A0 is synthesized as "1" bit. In the same manner, when it (A0 Pin) is set to "0" (VSS) or left floating, the Code Bit A0 is synthesized as a "0" or "F" bit respectively.



Remote Control Encoder IC

PT2264

CODE FRAME

A Code Frame consists of four (4) continuous Code Words. When PT2264 detects "0" on the /TE (meaning, the /TE is active "low"), it outputs a Code Frame at DOUT. If /TE is still active at the time the Code Frame transmission ends, PT2264 outputs another Code Frame. It should be noted that the Code Frame is synthesized at the time of transmission.

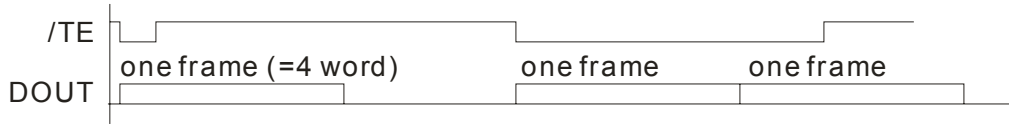

SIGNAL RESISTOR OSCILLATOR

The built-in oscillator circuitry of PT2264 allows a precision oscillator to be constructed by connecting an external resistor between OSC1 and OSC2 pins. For PT2294 to decode correctly the received waveform, the oscillator frequency of PT2294 must be 2.5 ~ 8 times that of transmitting PT2264. The typical oscillator with various resistor values are shown below for PT2264 and PT2294.

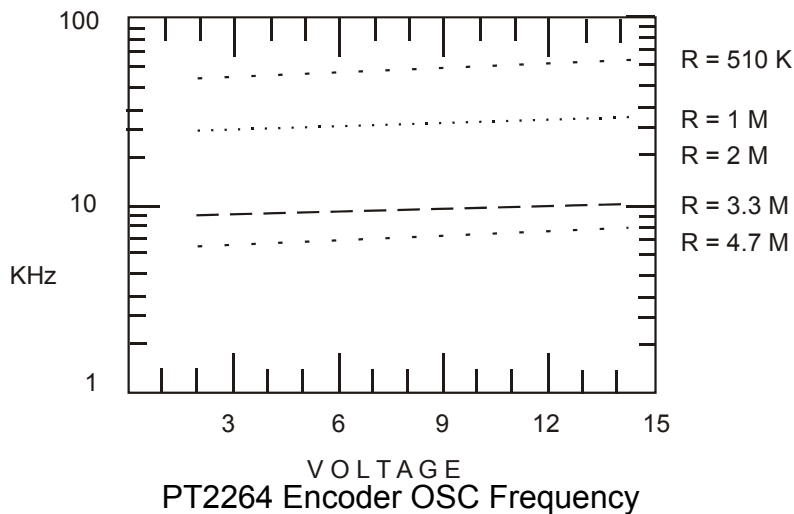



PT2294 DECODER OSC FREQUENCY

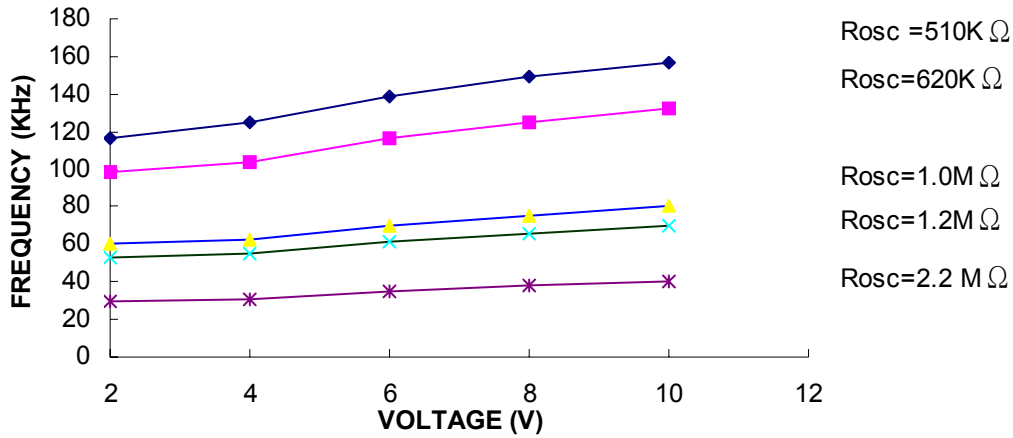

Suggested oscillator resistor values are shown below.

PT2264	PT2294
1.2M Ω	120K Ω
1.5M Ω	160K Ω
3.3M Ω	390K Ω



OPERATION FLOW CHART

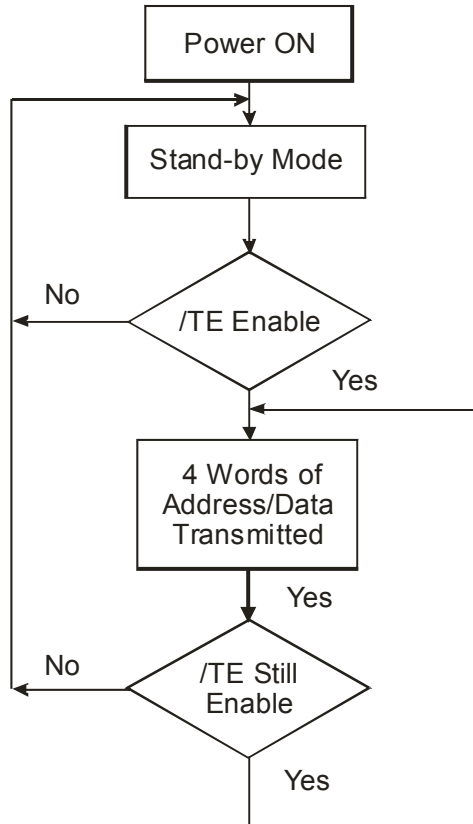



ABSOLUTE MAXIMUM RATINGS

Parameter	Symbol	Condition	Rating	Unit
Supply voltage	VCC		-0.3 ~ 16.0	V
Input voltage	VI		-0.3 ~ VCC+0.3	V
Output voltage	VO		-0.3 ~ VCC+0.3	V
Maximum power dissipation	Pa	VCC=12 V	300	mW
Operating temperature	Topr		-40 ~ +85	°C
Storage temperature	Tstg		-65 ~ +150	°C

DC ELECTRICAL CHARACTERISTICS

Parameter	Symbol	Conditions	Min.	Typ.	Max.	Unit
Supply voltage	VCC		8.0	-	15	V
Stand-by current	ISB	VCC=12V OSC2=12V A0 ~ A11 Open	-	0.1	1	μA
DOUT output driving current	IOH	VCC=8V VOH=4V	-6	-	-	mA
		VCC=12V VOH=6V	-10	-	-	mA
DOUT output sinking current	IOL	VCC=8V VOL=4V	5	-	-	mA
		VCC=12V VOL=6V	9	-	-	mA



APPLICATION CIRCUIT

4 Data transmitter circuit is recommended. Pin 1~8 Address Data can be selected by custom's design.

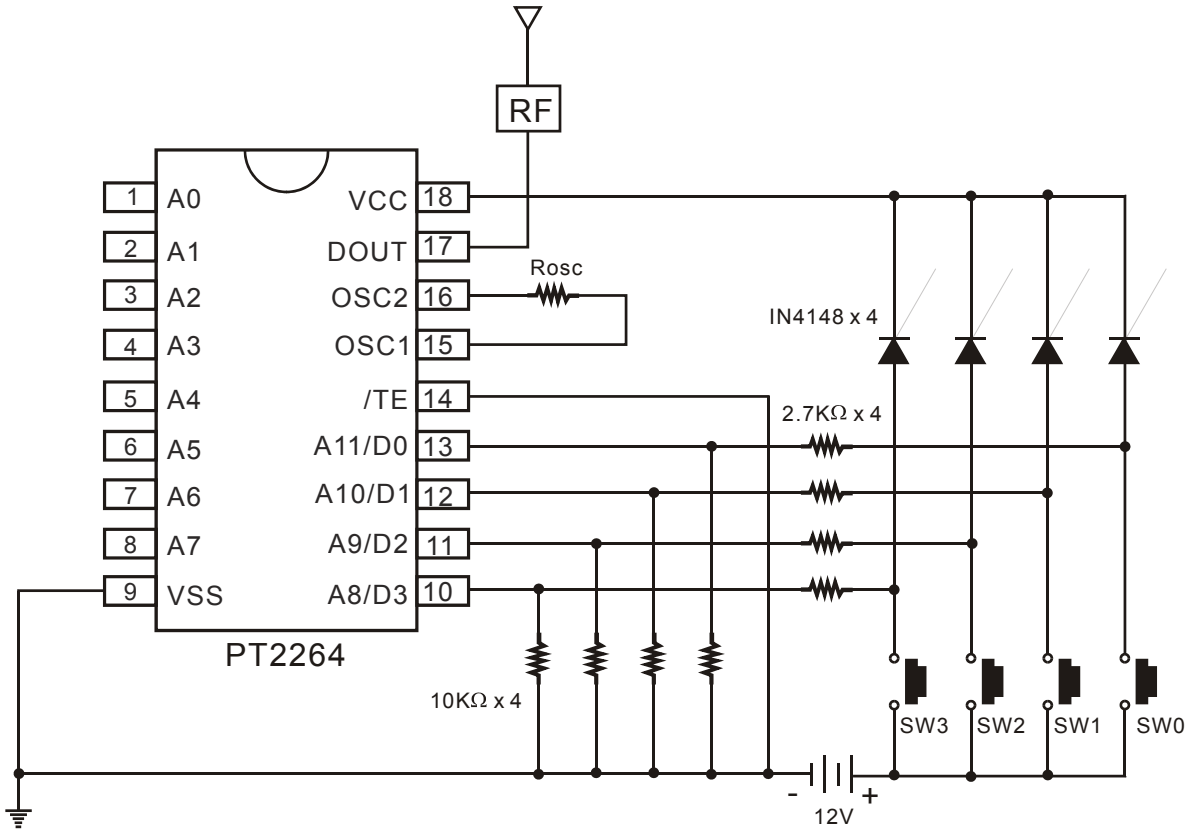

Note: Suggested oscillator resistor values (Rosc), please refer to page 7.



Remote Control Encoder IC

PT2264

Zero Data transmitter circuit is recommended. Pin 1~8, Pin 10~13 Address Data can be selected by custom's design.

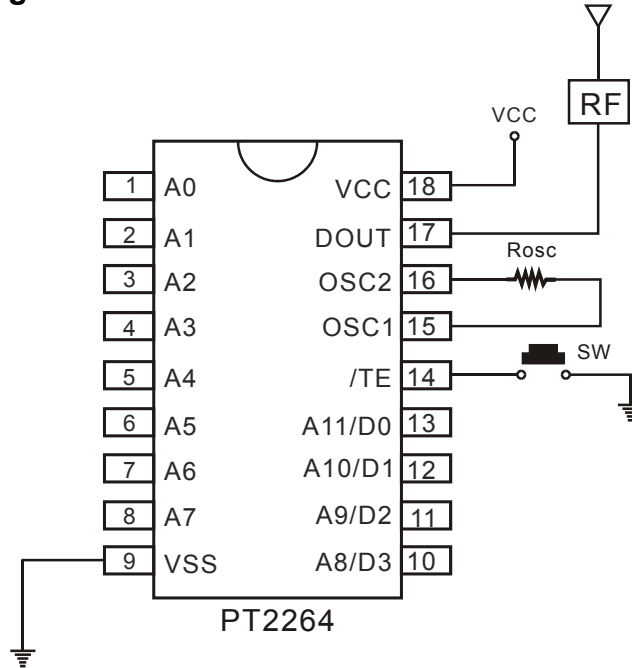

Note: Suggested oscillator resistor values (Rosc), please refer to page 7.

Zero-Stand-by transmitter circuit is recommended. Pin 1~8, Pin 10~13 Address Data can be selected by custom's design.

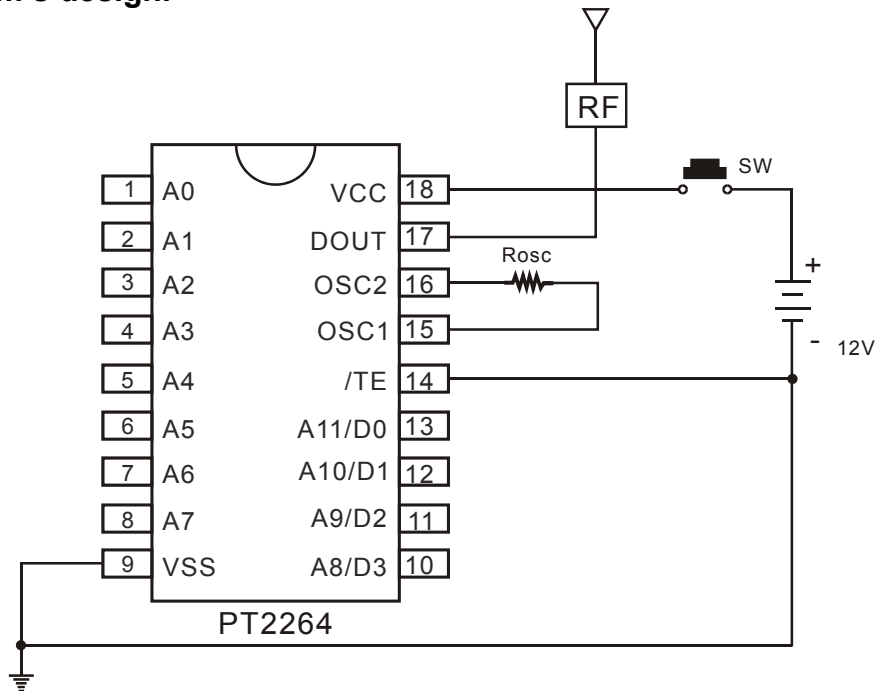

Note: Suggested oscillator resistor values (Rosc), please refer to page 7.



ORDER INFORMATION

Valid Part Number	Package Type	Top Code
PT2264	18 Pins, DIP, 300mil	PT2264
PT2264-18S	18 Pins, SOP, 300mil	PT2264-18S
PT2264-S	20 Pins, SOP, 300mil	PT2264-S



PACKAGE INFORMATION

18 PINS, DIP, 300MIL

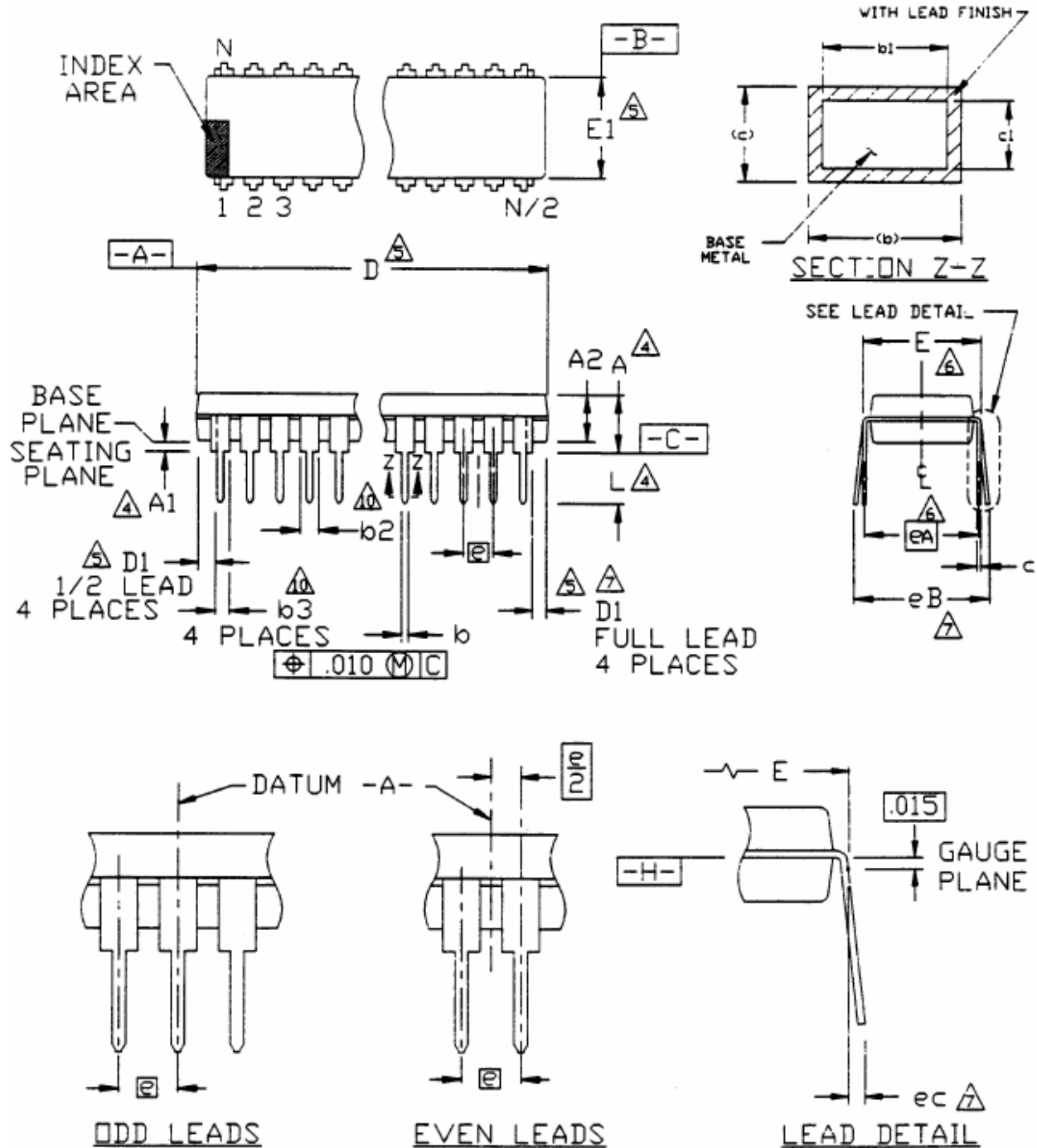



Remote Control Encoder IC

PT2264

Symbol	Min.	Nom.	Max.
A			0.210
A1	0.015		
A2	0.115	0.130	0.195
b	0.014	0.018	0.022
b1	0.014	0.018	0.020
b2	0.045	0.060	0.070
b3	0.030	0.039	0.045
c	0.008	0.010	0.014
c1	0.008	0.010	0.011
D	0.880	0.900	0.920
D1	0.005		
E	0.300	0.310	0.325
E1	0.240	0.250	0.280
e	0.100 bsc.		
eA	0.300 bsc.		
eB			0.430
eC	0.000		0.060
L	0.115	0.130	0.150

Notes:

- All dimensions are in INCHS.
- Dimensioning and tolerancing per ANSI Y14.5M-1982.
- Dimensions "A", "A1" and "L" are measured with the package seated in JEDEC Seating Plane Gauge GS-3.
- "D", "D1" and "E1" dimensions do not include mold flash or protrusions. Mold flash or protrusions shall not exceed 0.010 inch.
- "E" and "eA" measured with the leads constrained to be perpendicular to datum $\square{-C-}$.
- "eB" and "eC" are measured at the lead tips with the loads unconstrained.
- "N" is the number of terminal positions. (N=18)
- Pointed or rounded lead tips are preferred to ease insertion.
- "b2" and "b3" maximum dimensions are not include dambar protrusions. Dambar protrusions shall not exceed 0.010 inch (0.25 mm).
- Distance between leads including Dambar protrusions to be 0.005 inch minimum.
- Datum plane $\square{-H-}$ coincident with the bottom of lead, where lead exits body.
- Refer to JEDEC MS-001 Variation AC.

JEDEC is the trademark of JEDEC SOLID STATE TECHNOLOGY ASSOCIATION.



Remote Control Encoder IC

PT2264

18 PINS, SOP, 300MIL

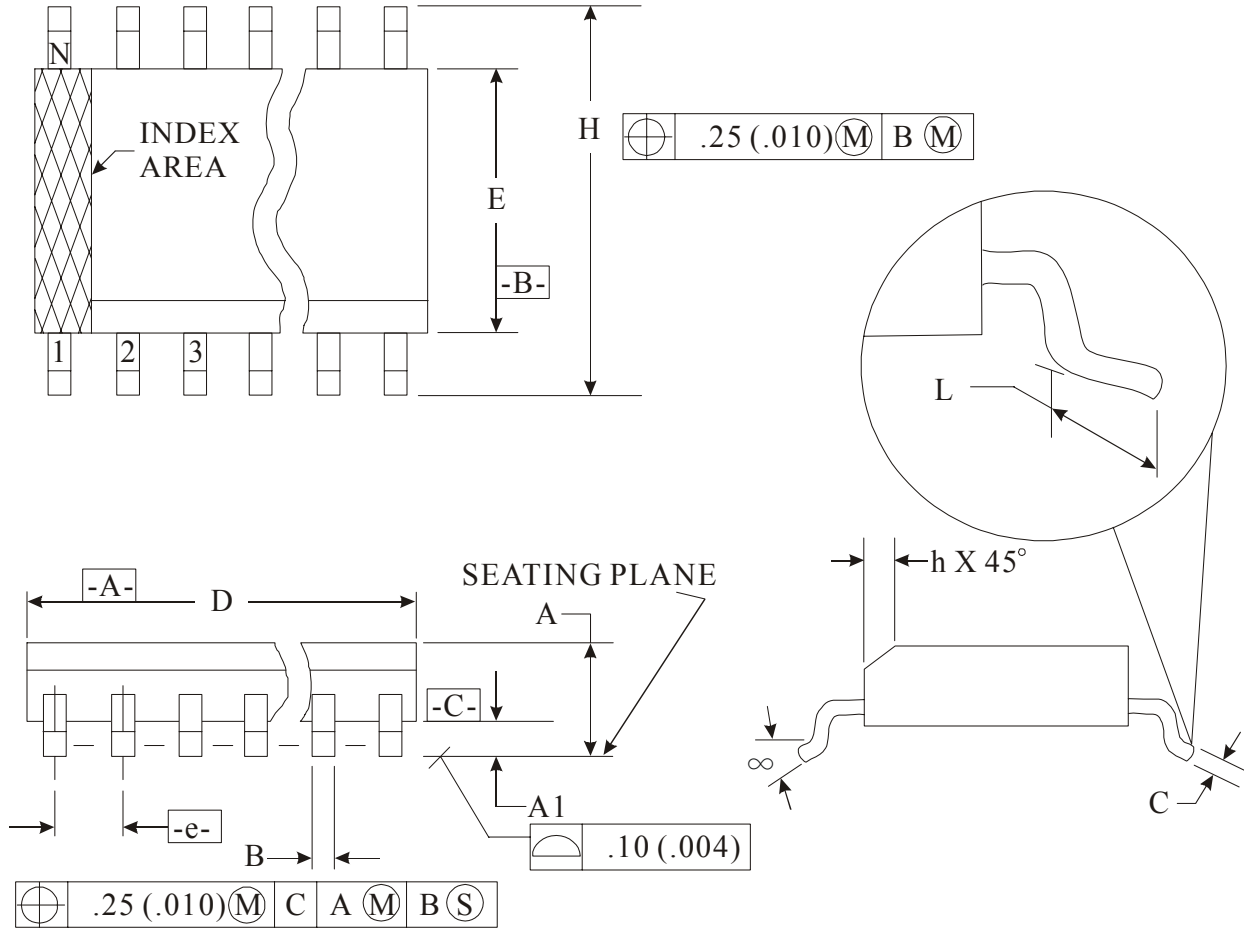

Symbol	Min.	Nom.	Max.
A	2.35		2.65
A1	0.10		0.30
B	0.33		0.51
C	0.23		0.32
D	11.35		11.75
E	7.40		7.60
e		1.27 bsc.	
H	10.00		10.65
h	0.25		0.75
L	0.40		1.27
α	0°		8°



Remote Control Encoder IC

PT2264

Notes:

1. Dimensioning and tolerancing per ANSI Y14.5M-1982.
2. Dimension "D" does not include mold flash, protrusions or gate burrs. Mold Flash, protrusion or gate burrs shall not exceed 0.15 mm (0.006 in) per side.
3. Dimension "E" does not include interlead flash or protrusions. Interlead flash or protrusions shall not exceed 0.25 mm (0.010 in) per side.
4. The chamfer on the body is optional. If it is not present, a visual index feature must be located within the crosshatched area.
5. "L" is the length of the terminal for soldering to a substrate.
6. N is the number of the terminal positions (N=18)
7. The lead width "B" as measured 0.36 mm (0.014 in) or greater above the seating plane, shall not exceed a maximum value of 0.61 mm (0.24 in).
8. Controlling dimension: MILLIMETER.
9. Refer to JEDEC MS-013, Variation AB.

JEDEC is the trademark of JEDEC SOLID STATE TECHNOLOGY ASSOCIATION.



Remote Control Encoder IC

PT2264

20 PINS, SOP, 300MIL

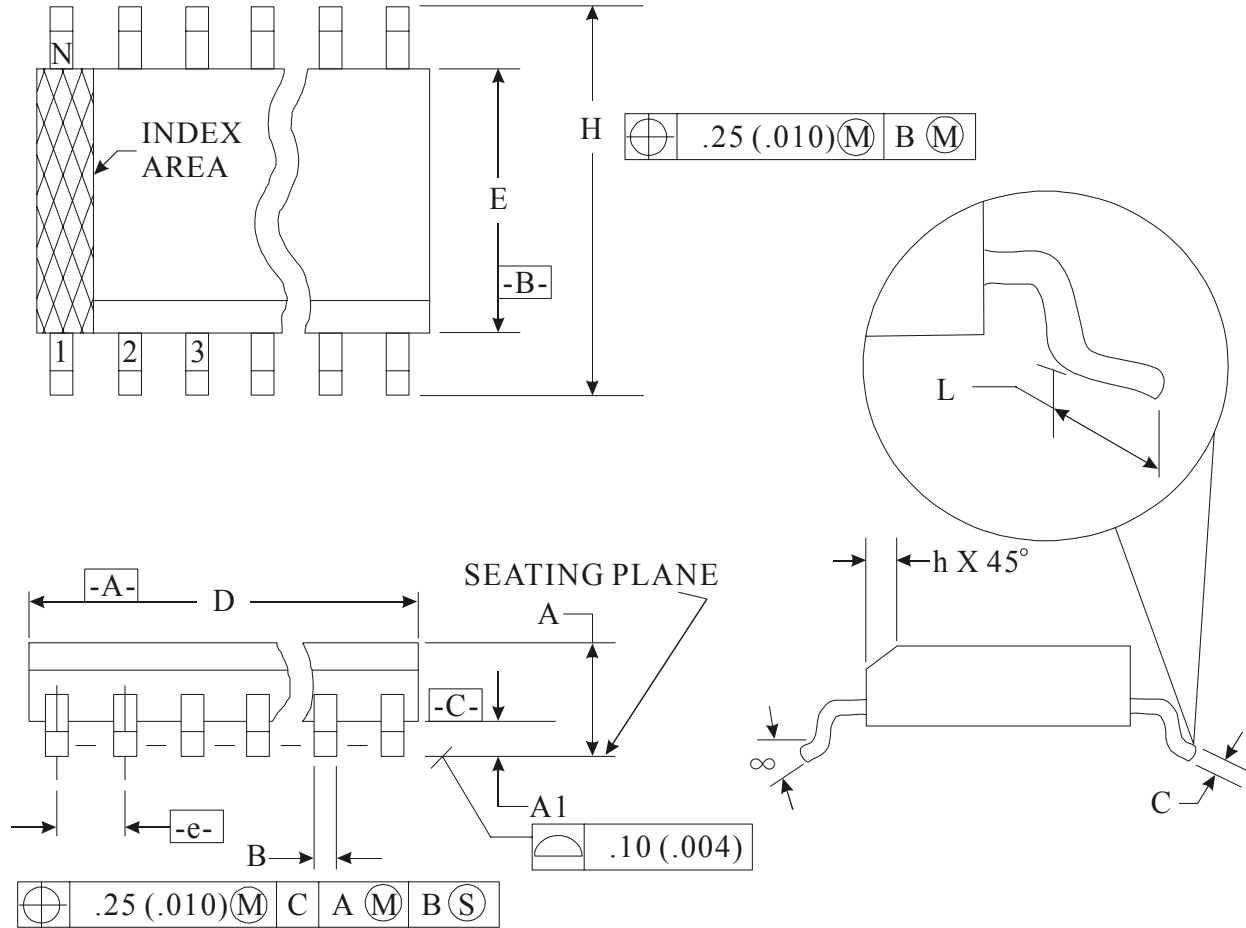

Symbol	Min.	Nom.	Max.
A	2.35		2.65
A1	0.10		0.30
B	0.33		0.51
C	0.23		0.32
D	12.60		13.00
E	7.40		7.60
e		1.27 bsc.	
H	10.00		10.65
h	0.25		0.75
L	0.40		1.27
α	0°		8°



Remote Control Encoder IC

PT2264

Notes:

1. Dimensioning and tolerancing per ANSI Y14.5M-1982.
 2. Dimension "D" does not include mold flash, protrusions or gate burrs. Mold Flash, protrusion or gate burrs shall not exceed 0.15 mm (0.006 in) per side.
 3. Dimension "E" does not include interlead flash or protrusions. Interlead flash or protrusions shall not exceed 0.25 mm (0.010 in) per side.
 4. The chamfer on the body is optional. If it is not present, a visual index feature must be located within the crosshatched area.
 5. "L" is the length of the terminal for soldering to a substrate.
 6. N is the number of the terminal positions (N=20)
 7. The lead width "B" as measured 0.36 mm (0.014 in) or greater above the seating plane, shall not exceed a maximum value of 0.61 mm (0.24 in).
 8. Controlling dimension: MILLIMETER.
 9. Refer to JEDEC MS-013, Variation AC.
- JEDEC is the trademark of JEDEC SOLID STATE TECHNOLOGY ASSOCIATION.