

## DESCRIPTION

PT2262 is a remote control encoder paired with PT2272 utilizing CMOS Technology. It encodes data and address pins into a serial coded waveform suitable for RF or IR modulation. PT2262 has a maximum of 12 bits of tri-state address pins providing up to 531,441 (or 312) address codes; thereby, drastically reducing any code collision and unauthorized code scanning possibilities.

## FEATURES

- CMOS Technology
- Low Power Consumption
- Very High Noise Immunity
- Up to 12 Tri-State Code Address Pins
- Up to 6 Data Pins
- Wide Range of Operating Voltage:  $V_{cc} = 4 \sim 15V$
- Single Resistor Oscillator
- Latch or Momentary Output Type
- Available in DIP and SOP

## APPLICATIONS

- Car Security System
- Garage Door Controller
- Remote Control Fan
- Home Security/Automation System
- Remote Control Toys
- Remote Control for Industrial Use

## BLOCK DIAGRAM

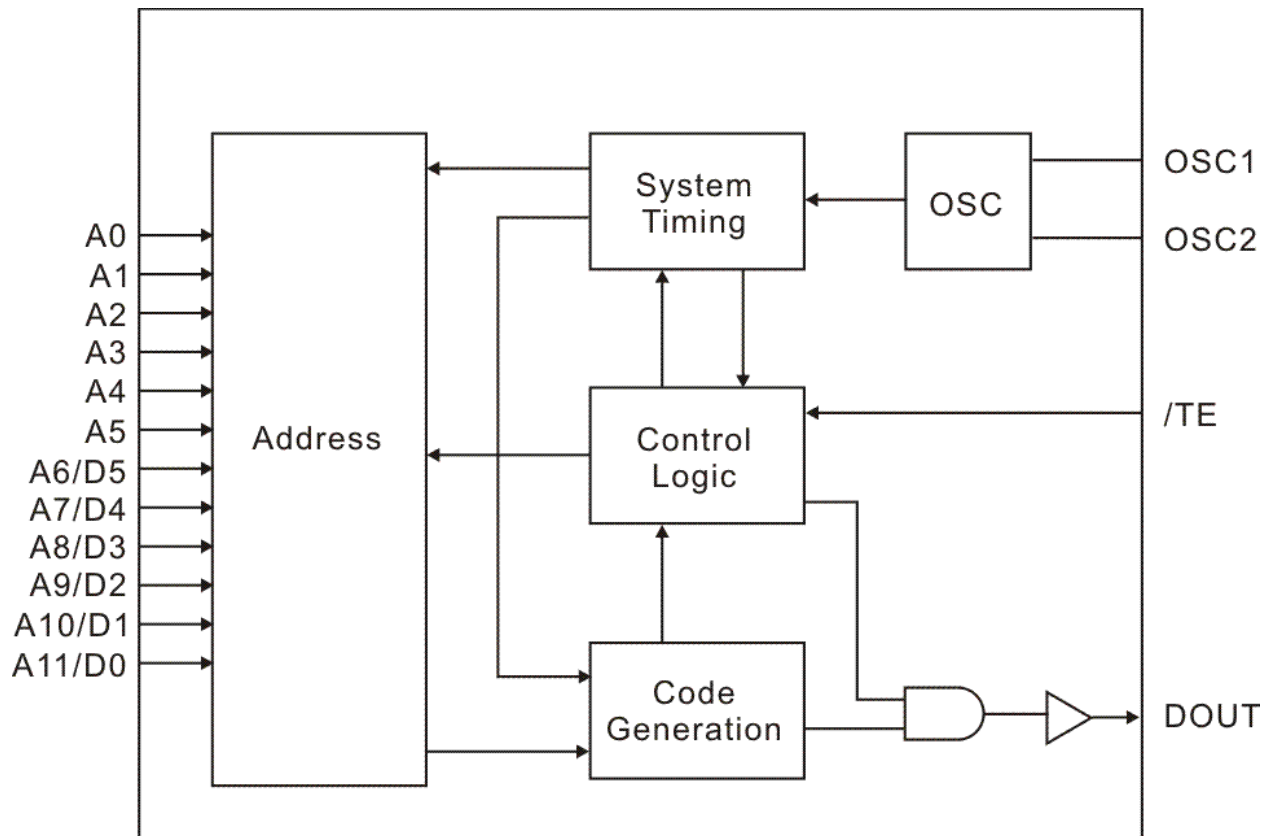

# APPLICATION CIRCUITS

**UHF BAND 4 DATA TRANSMITTER CIRCUIT IS RECOMMENDED**

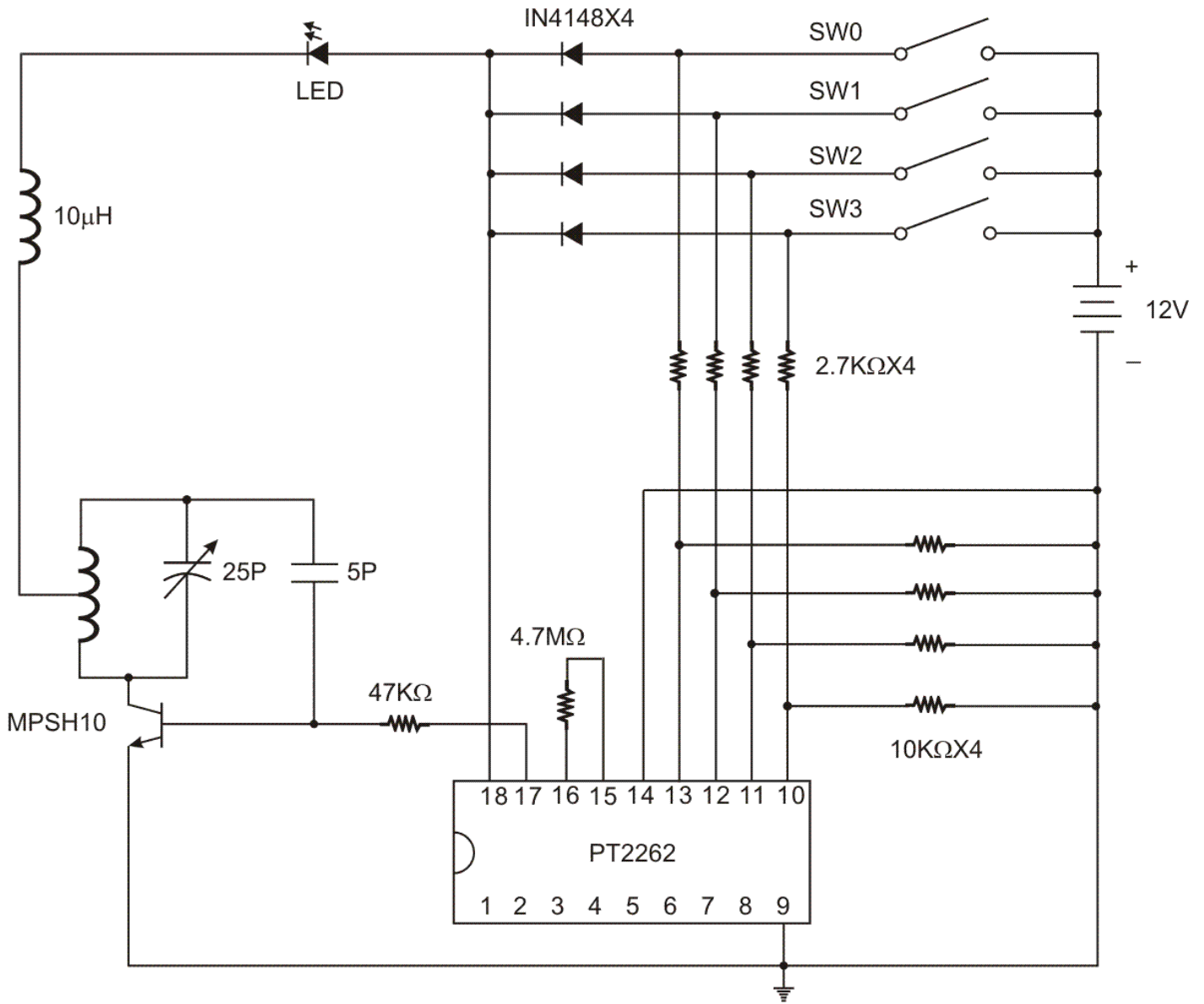

**UHF BAND ADDRESS-ONLY (ZERO DATA) TRANSMITTER CIRCUIT IS RECOMMENDED**

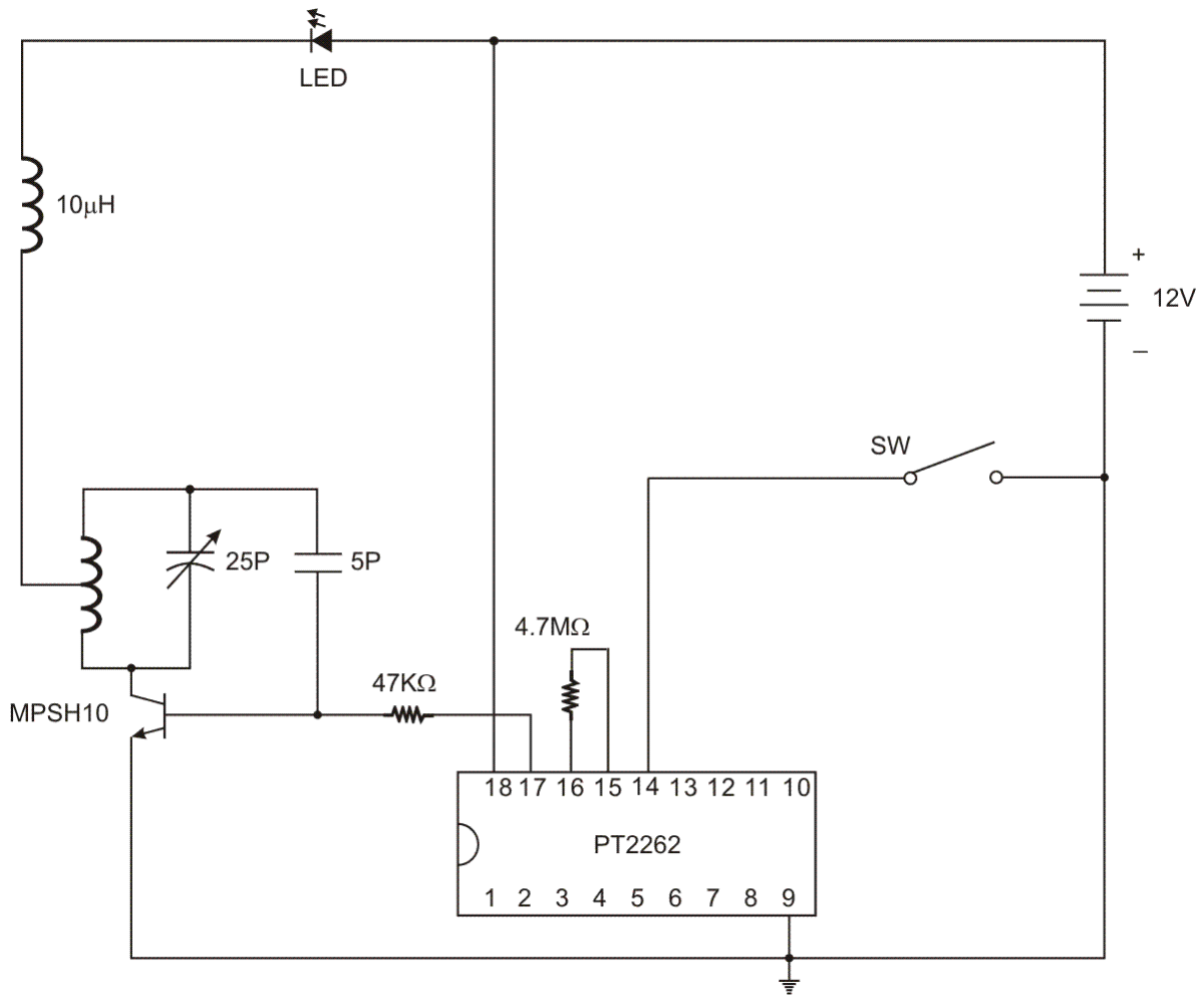

**UHF BAND ADDRESS-ONLY (ZERO DATA) ZERO-STAND-BY TRANSMITTER CIRCUIT IS RECOMMENDED.**

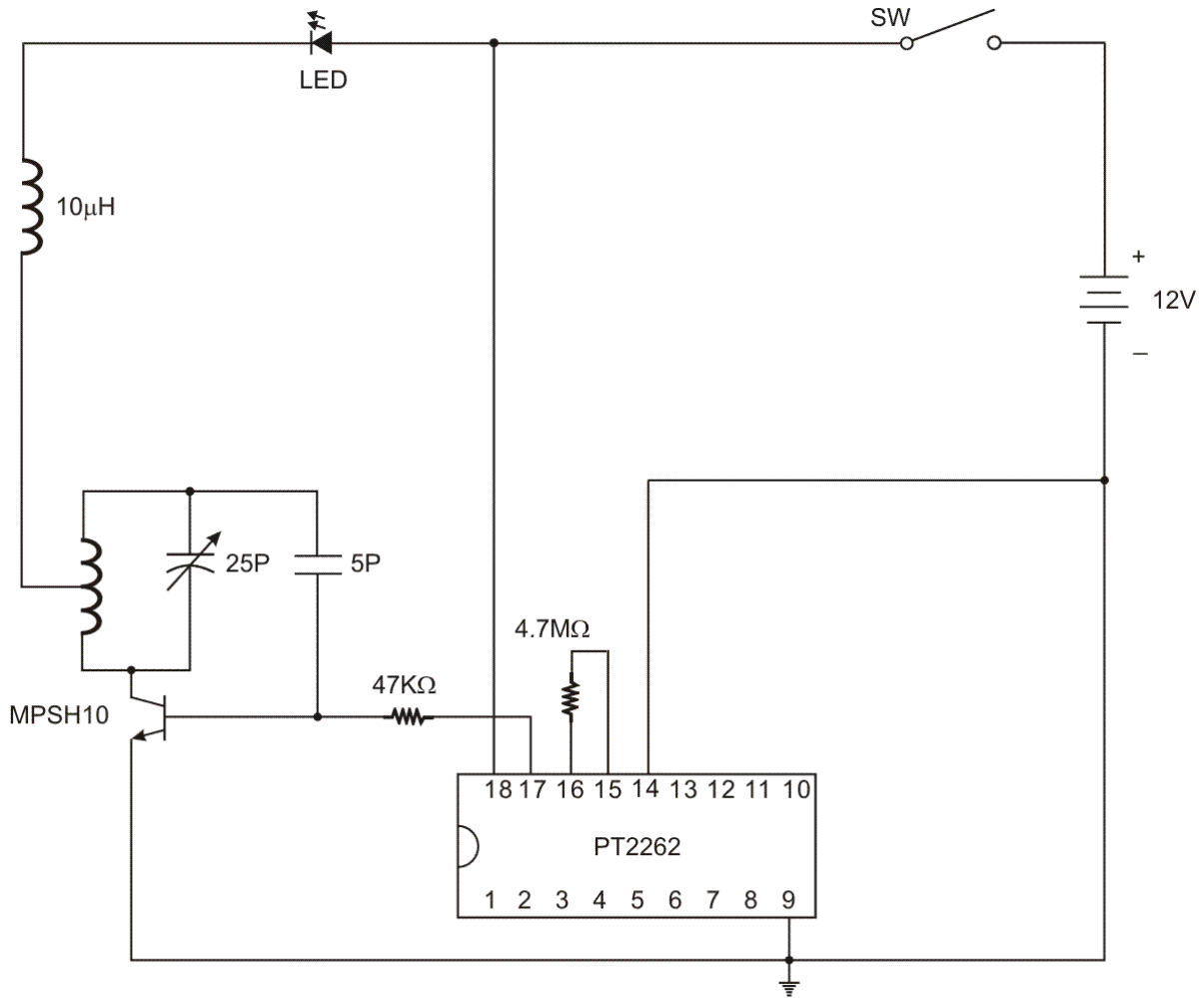

**INFRARED RAY 6-DATA CIRCUIT. ADJUST ROSC TO GET 38KHZ CARRIER PULSE AT DOUT PIN IS RECOMMENDED.**

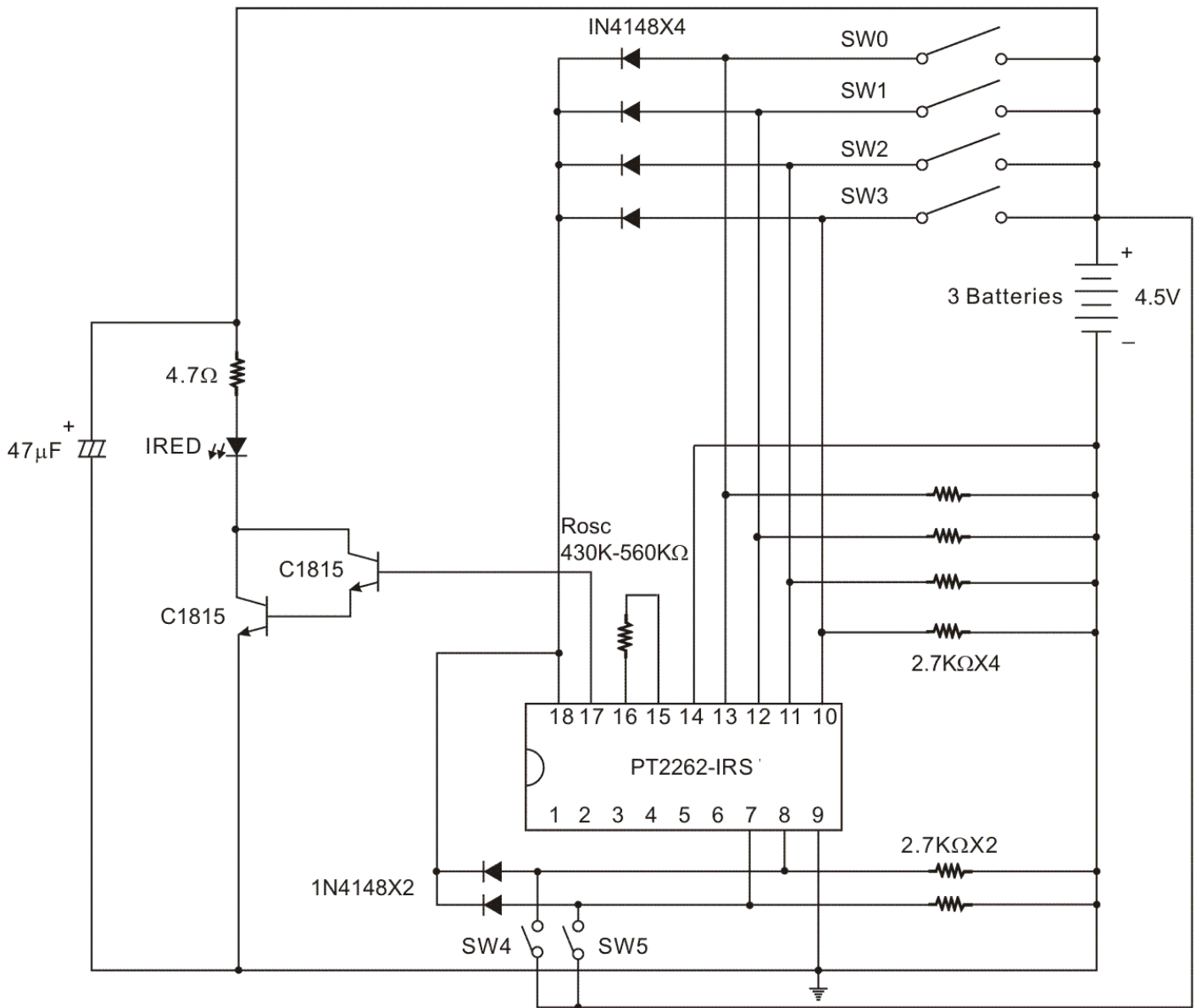

## ORDERING INFORMATION

Valid Part Number	Package Type	Top ode
PT2262	18 Pins, DIP, 300mil	PT2262
PT2262-S18	18 Pins, SOP, 300mil	PT2262-S18
PT2262-S	20 Pins, SOP, 300mil	PT2262-S
PT2262-IRS	20 Pins, SOP, 300mil	PT2262-IRS

## PIN CONFIGURATION

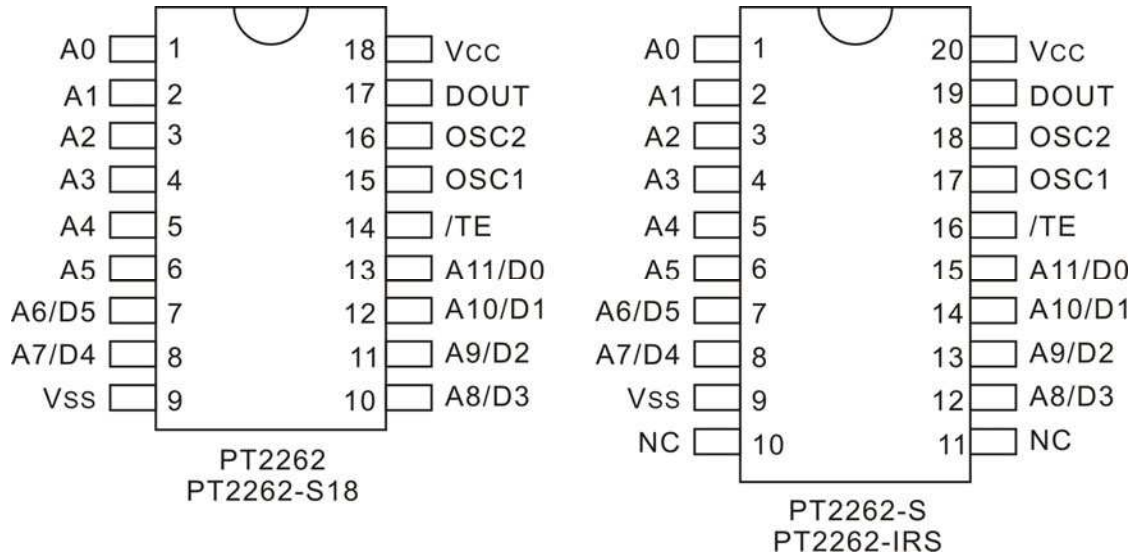

## PIN DESCRIPTION

Pin Name	I/O	Description	Pin No.	
			18 Pins	20 Pins
A0 ~ A5	I	Code Address Pin Nos.0 ~ 5 These six tri-state pins are detected by PT2262 to determine the encoded waveform bit 0 ~ bit 5. Each pin can be set to "0", "1" or "f" (floating).	1 ~ 6	1 ~ 6
A6/D5, A7/D4 A8/D3 ~ A11/D0	I	Code Address Pin Nos.6 ~ 11/Data Pin Nos.5 ~ 0. These six tri-state pins are detected by PT2262 to determine the encoded waveform bit 6 ~ bit 11. When these pins are used as address pins, they can be set to "0", "1", or "f" (floating). When these pins are used as data pins, they can be set only to "0" or "1".	7, 8 10 ~ 13	7, 8 12 ~ 15
/TE	I	Transmission Enable. Active Low Signal. PT2262 outputs the encoded waveform to DOUT when this pin is pulled to low.	14	16
OSC1	O	Oscillator Pin No.1	15	17
OSC2	I	Oscillator Pin No.2		
DOUT	O	Data Output Pin. The encoded waveform is serially outputted to this pin. When PT2262 is not transmitting, DOUT outputs low (Vss) voltage.	17	19
Vcc	-	Positive Power Supply	18	20
Vss	-	Negative Power Supply	9	9

## FUNCTIONAL DESCRIPTION

PT2262 encodes the code address and data set at A0 ~ A5 and A6/D5 ~ A11/D0 into a special waveform and outputs it to the DOUT when TE is pulled to "0" (Low State). This waveform is fed to either the RF modulator or the IR transmitter for transmission. The transmitted radio frequency or infrared ray is received by the RF demodulator or IR receiver and reshaped to the special waveform. PT2272 is then used to decode the waveform and set the corresponding output pin(s). Thus completing a remote control encoding and decoding function.

## RF OPERATION

### CODE BITS

A Code Bit is the basic component of the encoded waveform, and can be classified as either an AD (Address/Data) Bit or a SYNC (Synchronous) Bit.

#### ADDRESS/DATA (AD) BIT WAVEFORM

An AD Bit can be designated as Bit "0", "1" or "f" if it is in low, high or floating state respectively. One bit waveform consists of 2 pulse cycles. Each pulse cycle has 16 oscillating time periods. For further details, please refer to the diagram below:

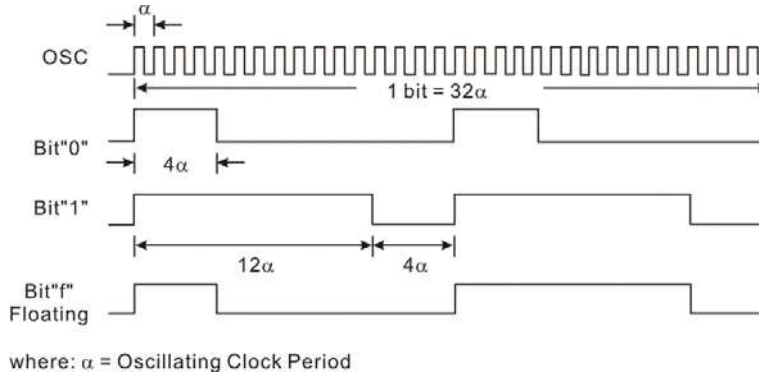

#### SYNCHRONOUS (SYNC.) BIT WAVEFORM

The Synchronous Bit Waveform is 4 bits long with 1/8 bit width pulse. Please refer to the diagram below:

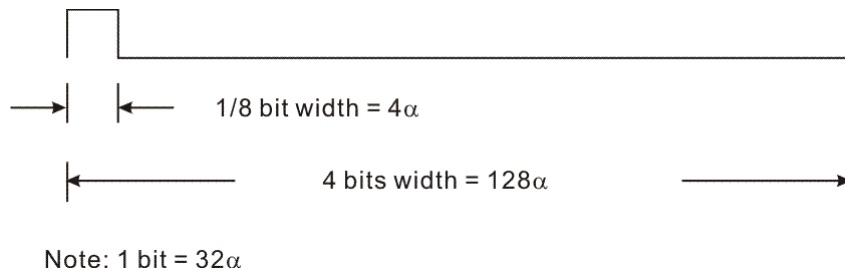

### CODE WORD

A group of Code Bits is called a Code Word. A Code Word consists of 12 AD bits followed by one Sync Bit. The 12 AD bits are determined by the corresponding states of A0 ~ A5 and A6/D5 ~ A11/D0 pins at the time of transmission. When Data Type of PT2262 is used, the address bits will decrease accordingly.

For example: In the 3 Data Type where the address has nine (9) bits, the transmitting format is:

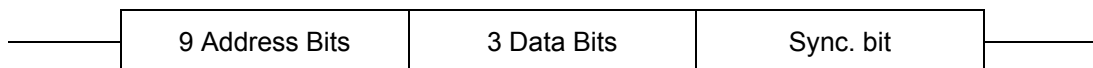

PT2262 / PT2272 has a maximum of twelve (12) Address Bits including the six (6) Address/Data bits. The following diagram shows the code bits with their corresponding pins.

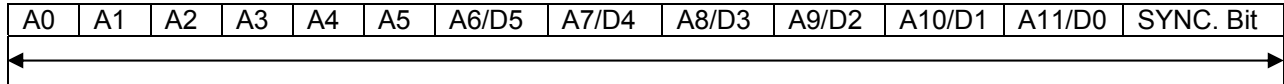

One Complete Code Word

0 Data:	A0	A1	A2	A3	A4	A5	A6	A7	A8	A9	A10	A11	Sync Bit
1 Data:	A0	A1	A2	A3	A4	A5	A6	A7	A8	A9	A10	D0	Sync Bit
2 Data:	A0	A1	A2	A3	A4	A5	A6	A7	A8	A9	D1	D0	Sync.Bit
3 Data:	A0	A1	A2	A3	A4	A5	A6	A7	A8	D2	D1	D0	Sync.Bit
4 Data:	A0	A1	A2	A3	A4	A5	A6	A7	D3	D2	D1	D0	Sync.Bit
5 Data:	A0	A1	A2	A3	A4	A5	A6	D4	D3	D2	D1	D0	Sync.Bit
6 Data:	A0	A1	A2	A3	A4	A5	D5	D4	D3	D2	D1	D0	Sync.Bit

The Code Bits A0 ~ A5 and A6/D5 ~ A11/D0 are determined by the states of A0 ~ A5 and A6/D5 ~ A11/D0 pins. For example, when the A0 (Pin No. 1) is set to "1" (Vcc), the Code Bit A0 is synthesized as "1" bit. In the same manner, when it (A0 Pin) is set to "0" (Vss) or left floating, the Code Bit A0 is synthesized as a "0" or "1" bit respectively.

### CODE FRAME

A Code Frame consists of four (4) continuous Code Words. When PT2262 detects "0" on the /TE (meaning, the /TE is active "low"), it outputs a Code Frame at DOUT. If /TE is still active at the time the Code Frame transmission ends, T2262 outputs another Code Frame. It should be noted that the Code Frame is synthesized at the time of transmission.

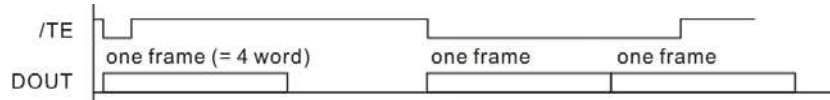

### SIGNAL RESISTOR OSCILLATOR

The built-in oscillator circuitry of PT2262 allows a precision oscillator to be constructed by connecting an external resistor between OSC1 and OSC2 pins. For PT2272 to decode correctly the received waveform, the oscillator frequency of PT2272 must be 2.5 ~ 8 times that of transmitting PT2262. The typical oscillator frequency with various resistor values for both PT2262 and PT2272 are shown below:

**Encoder OSC Frequency**

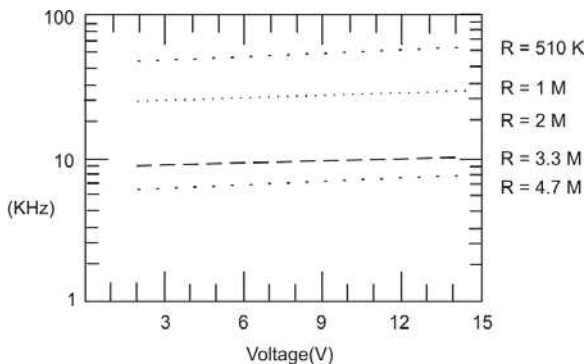

**Decoder OSC Frequency**

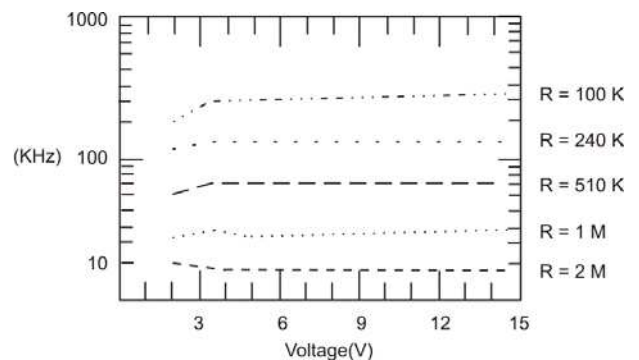

Suggested oscillator resistor values are shown below.

PT2262	PT2272
4.7 M	820 K*
3.3 M	680 K*
1.2 M	200 K**

Note:

\* -- Operates when PT2272's Vcc=5V to 15V

\*\* -- Operates when PT2272's Vcc=3V to 15V

This means that if PT2272 supply voltage is lower than 5V, you need to use a lower oscillator resistor value for both PT2262 and PT2272.

## IR OPERATION

In the IR Type of Operation, the functions are similar to the above descriptions except for the output waveform that has a carrier frequency of 38KHz. Details are as follows:

### CODE BITS

The Code Bits are further modulated with a 38KHz carrier frequency and can be "0", "1" or "f" bit. Their waveforms are shown in the diagram below.

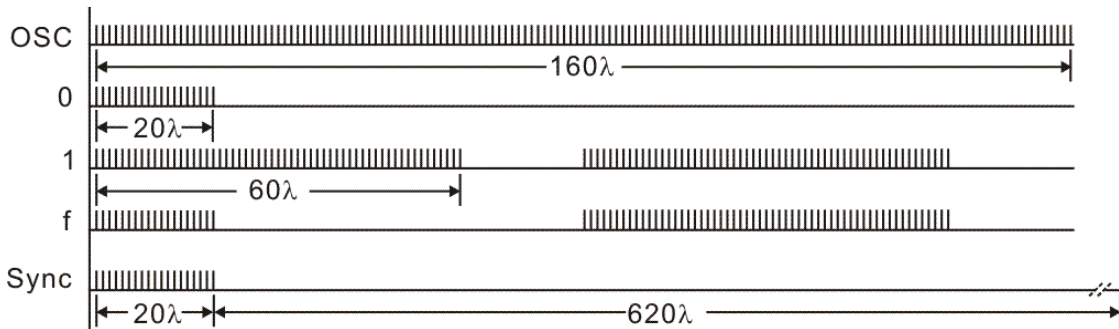

Note :  $\lambda = 2$  clock lengths

### CODE WORD

A Code Word is made up of code bits and the format is the same as that of the RF Code Word.

### CODE FRAME

Likewise, a Code Frame is made up of Code Words and the format is the same as that of RF Type of Operation.

### OSCILLATOR

The Oscillator Frequency for the IR Type of Operation is twice the carrier frequency. Thus, the oscillator frequency should be kept at 76 KHz. A 430K ~ 560K $\Omega$  oscillator resistor between OSC 1 and OSC 2 pins is recommended. It should be noted that the carrier is a 50% duty cycle frequency.

### OPERATION FLOW CHART

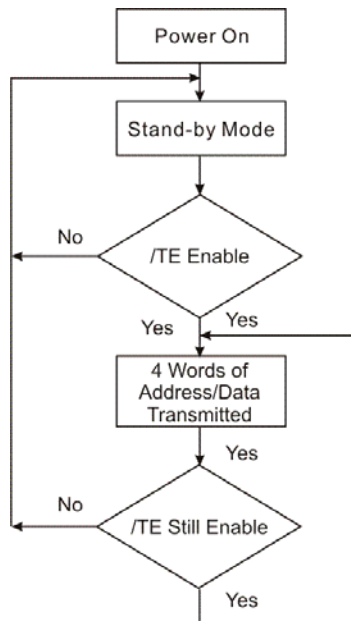

## ABSOLUTE MAXIMUM RATING

Parameter	Symbol	Condition	Rating	Unit
Supply Voltage	Vcc		-0.3 ~ 16.0	V
Input Voltage	VI		-0.3 ~ Vcc+0.3	V
Output Voltage	VO		-0.3 ~ Vcc+0.3	V
Maximum Power Dissipation	Pa	Vcc = 12V	300	mW
Operating Temperature	Topr		-40 ~ +85	°C
Storage Temperature	Tstg		-65 ~ 150	°C

## DC ELECTRICAL CHARACTERISTICS

Parameter	Symbol	Test Condition	Min.	Typ.	Max.	Unit
Supply Voltage	Vcc		4		15	V
Stand-by Current	ISB	Vcc = 12V OSC2 = 12V A0 ~ A11 Open		0.1	1	μA
DOUT Output Driving Current	IOH	Vcc = 5V, VOH = 3V	-3			mA
		Vcc = 8V, VOH = 4V	-6			mA
		Vcc = 12V, VOH = 6V	-10			mA
DOUT Output Sinking Current	IOL	Vcc = 5V, VOL=3V	2			mA
		Vcc = 8V, VOL = 4V	5			mA
		Vcc = 12V, VOL = 6V	9			mA

# PACKAGE INFORMATION

18 PINS, DIP, 300MIL

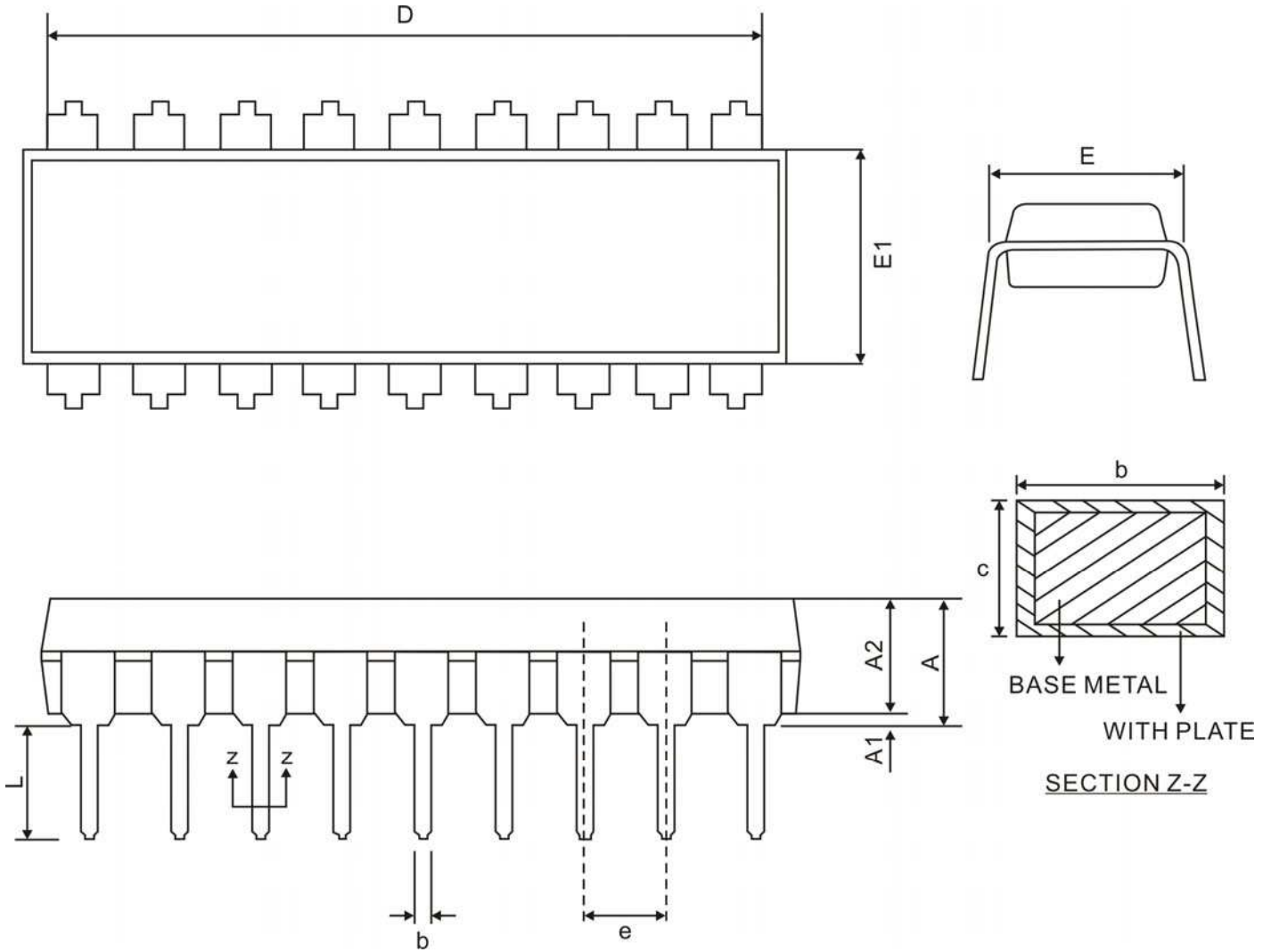

Symbol	Dimension		
	Min.	Nom.	Max.
A	-	-	5.33
A1	0.38	-	-
A2	2.92	3.30	4.95
b	0.36	-	0.56
c	0.20	-	0.36
e	2.54 BSC		
D	22.35	22.86	23.37
E	7.62	7.87	8.26
E1	6.10	6.35	7.11
L	2.92	3.30	3.81

Notes:  
 1. Refer to JEDEC MS-001 AC  
 2. Unit: mm

**18 PINS, SOP, 300MIL**

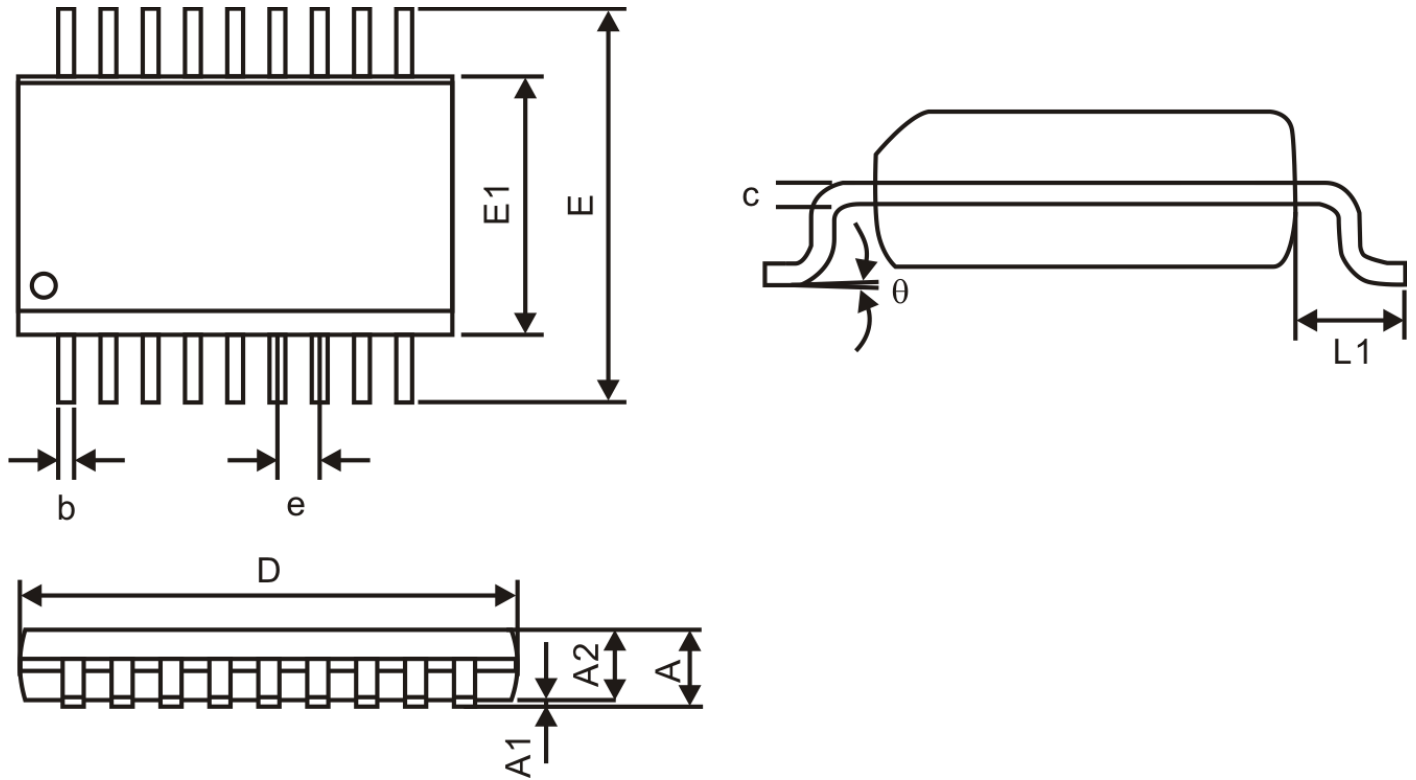

Symbol	Dimension		
	Min.	Nom.	Max.
A	-	-	2.65
A1	0.10	-	0.30
A2	2.05	-	-
b	0.31	-	0.51
c	0.20	-	0.33
e	1.27 BSC		
D	11.55 BSC		
E	10.3 BSC		
E1	7.5 BSC		
L1	1.40 BSC		
$\theta$	0°	-	8°

Notes:  
 1. Refer to JEDEC MS-013 AB  
 2. Unit: mm

**20 PINS, SOP, 300 MIL**

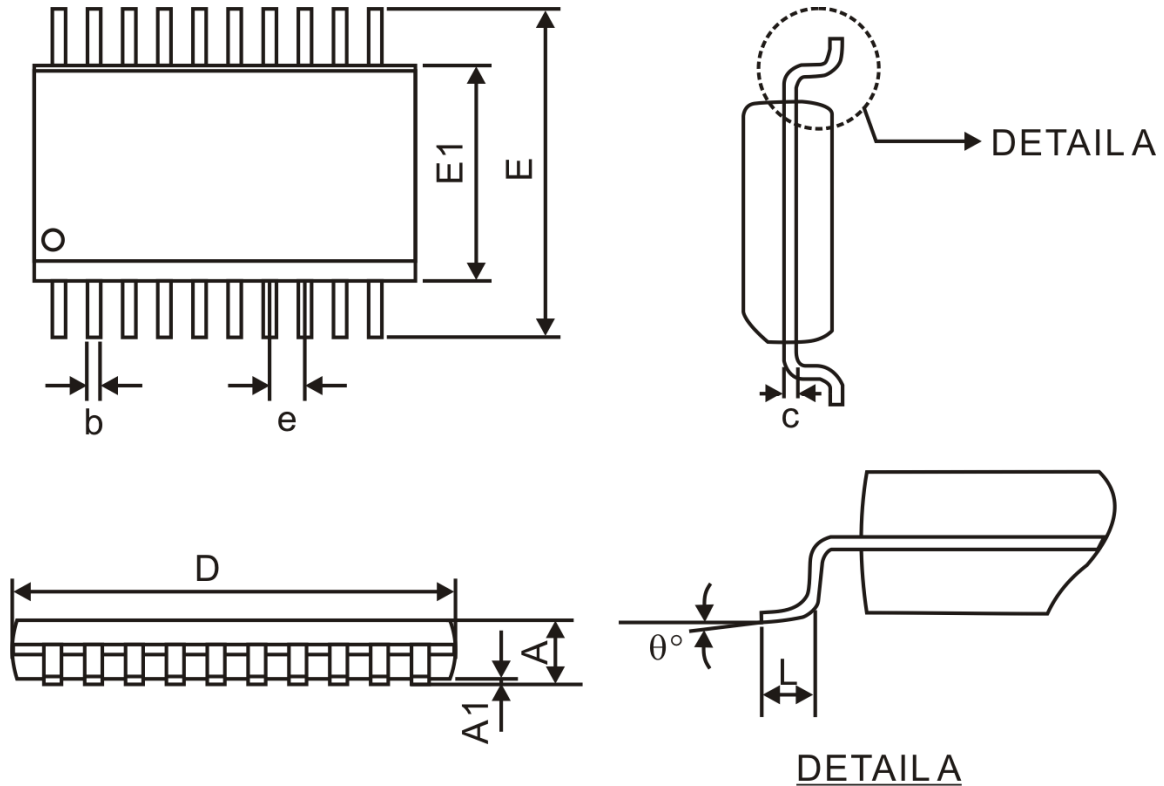

Symbol	Dimension		
	Min.	Nom.	Max.
A	-	-	2.65
A1	0.10	-	0.30
b	0.31	-	0.51
c	0.20	-	0.33
e	1.27 BSC		
D	12.80 BSC		
E	10.3 BSC		
E1	7.5 BSC		
L	0.4	-	1.27
$\theta$	0°	-	8°

Notes:  
1. Refer to JEDEC MS-013 AC  
2. Unit: mm

**IMPORTANT NOTICE**

Princeton Technology Corporation (PTC) reserves the right to make corrections, modifications, enhancements, improvements, and other changes to its products and to discontinue any product without notice at any time.

PTC cannot assume responsibility for use of any circuitry other than circuitry entirely embodied in a PTC product. No circuit patent licenses are implied.

Princeton Technology Corp.  
2F, 233-1, Baociao Road,  
Sindian, Taipei 23145, Taiwan  
Tel: 886-2-66296288  
Fax: 886-2-29174598  
<http://www.princeton.com.tw>