



DESCRIPTION

PT2389 is a 2-channel digital preset equalizer utilizing CMOS Technology. It provides 5 different sound selections, namely: Flat/Normal, Rock, Pops, Classic and Jazz. Bass Booster and 3D Effects may be added to any of 5 sound selections, thereby creating more audio versatility. PT2389 provides two types of key selection mode, namely: the Direct and the Cyclic. Pin assignment and application circuit are optimized for cost saving advantages and easy PCB layout.

FEATURES

- CMOS technology
- Low total harmonic distortion and high S/N Ratio: THD + N < 0.01%, S/N > 95dB
- LED display output mode
- Least external components
- 5 sound selections provided: Flat/Normal, Classic, Rock, Pops, and Jazz
- Bass booster function & 3D effect provided
- 2-channel output
- Wide operating voltage range: 5 ~ 9V
- Direct or cyclic key selection is provided
- Available in 24 Pins, DIP, SOP, SSOP

APPLICATIONS

- Walkman
- Car audio
- Mini compo
- Multimedia audio components
- MPEG card



5-Mode Preset Equalizer IC with Bass Booster & 3D Effect

PT2389

BLOCK DIAGRAM

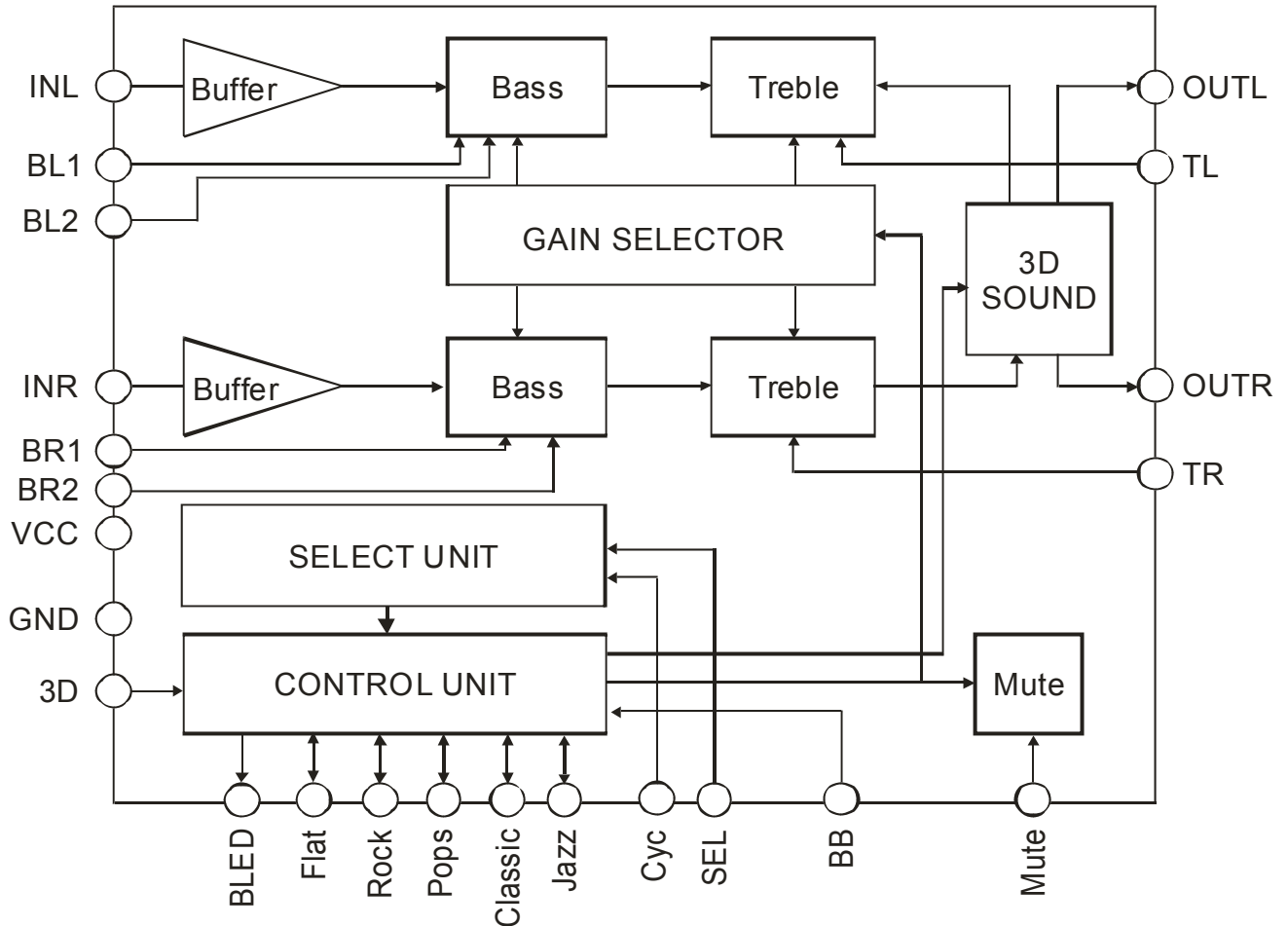



PIN CONFIGURATION

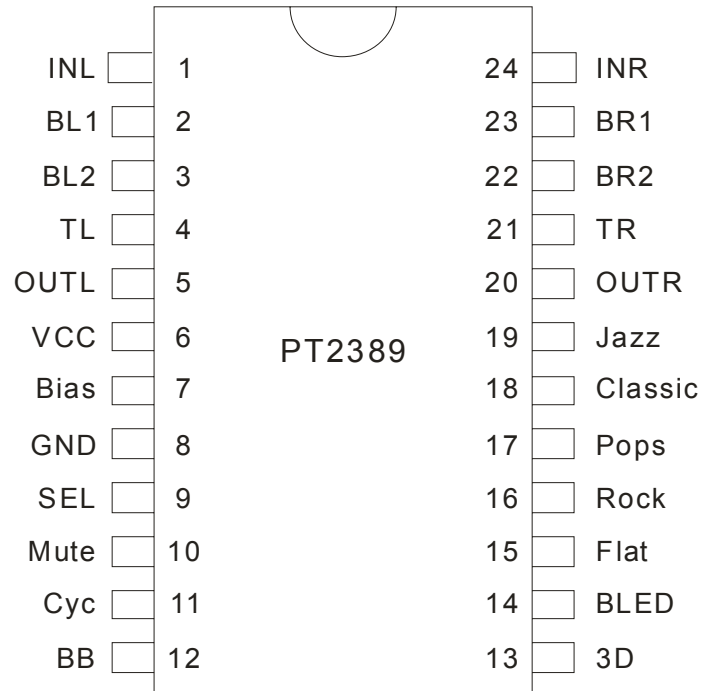



5-Mode Preset Equalizer IC with Bass Booster & 3D Effect

PT2389

PIN DESCRIPTION

Pin Name	I/O	Description	Pin No.
INL	I	Left Channel Input	1
BL1	-	Left Bass Control Pin 1 A capacitor is connected between this pin and BL2	2
BL2	-	Left Bass Control Pin 2 A capacitor is connected between this pin and BL1	3
TL	-	Left Treble Control Pin A capacitor is connected between this pin and OUTL	4
OUTL	O	Left Channel Output Pin	5
VCC	-	Positive Supply Voltage	6
Bias	-	A capacitor is connected between this pin and GND	7
GND	-	Ground	8
SEL	I	Select Control Pin	9
Mute	-	Mute Pin The Mute pin can eliminate the noise when mode charging occurs. A capacitor is connected between this pin and GND	10
Cyc	I	Cyclic Select Pin	11
BB	I	Bass Booster Control Input Pin	12
3D	I/O	3D Effect Control Input Pin/Output LED Pin	13
BLED	O	Bass Booster Display Pin	14
Flat	I/O	Flat Mode Display & Control Input Pin	15
Rock	I/O	Rock Mode Display & Control Input Pin	16
Pops	I/O	Pops Mode Display & Control Input Pin	17
Classic	I/O	Classic Mode Display & Control Input Pin	18
Jazz	I/O	Jazz Mode Display & Control Input Pin	19
OUTR	O	Right Channel Output Pin	20
TR	-	Right Treble Control Pin A capacitor is connected between this pin and OUTR	21
BR2	-	Right Bass Control Pin 2 A capacitor is connected between this pin and BR1	22
BR1	-	Right Bass Control Pin 1 A capacitor is connected between this pin and BR2	23
INR	I	Right Channel Input Pin	24



5-Mode Preset Equalizer IC with Bass Booster & 3D Effect

PT2389

FUNCTION DESCRIPTION

PT2389 is a 5-Mode Preset Equalizer IC with a Bass Booster and 3D Effects. It has 2 types of key selection mode, namely: Direct and Cyclic. The Direct or Cyclic Key Selection Mode is determined by the SEL Pin. Please refer to the table below:

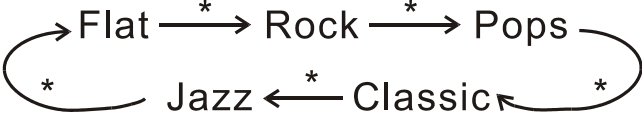
	SEL pin	Description
Direct	Low	Press Flat key→Flat mode Press Rock key→Rock mode Press Pops key→Pops mode Press Classic key→Classic mode Press Jazz key→Jazz mode
Cyclic *	Floating/High	 * Press Cyc Key

Note:

The Bass Booster Function and the 3D Effect can be controlled in the same manner under the Direct or the Cyclic Key Selection Mode. To turn the Bass Booster On or Off, press the BB Key. To turn the 3D Effect On or Off, press the 3D Key.

CYCLIC KEY SELECTION MODE

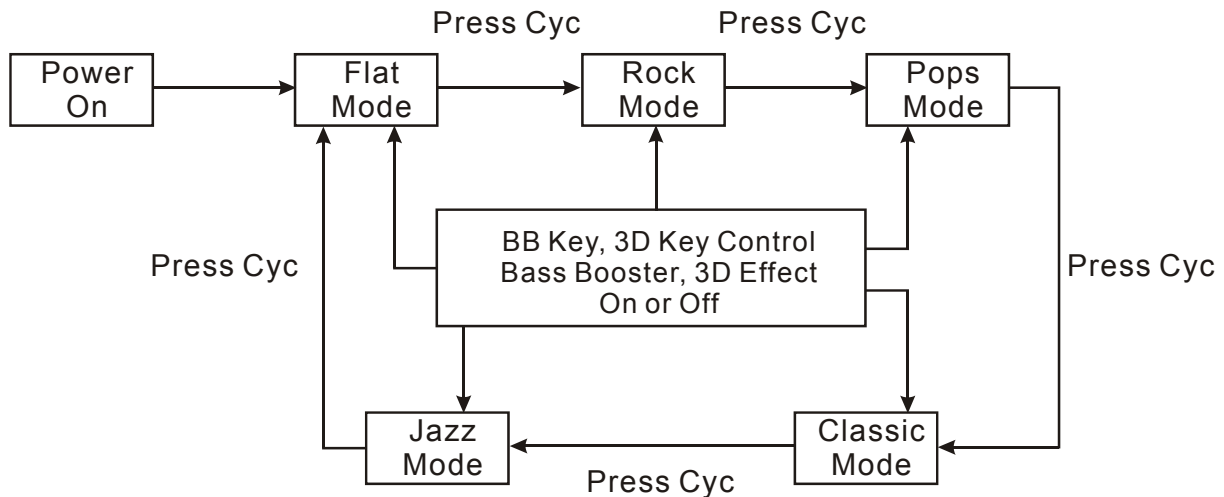

After power on, PT2389 is Flat Mode, under this mode, any of the sound selections (Flat, Rock, Pops, Classic, Jazz) may be selected by pressing the CYC Key. BB key and 3D key is the switch of Bass Booster and 3D Effect (Bass Booster and 3D Effect if Off when Power On)



DIRECT KEY SELECTION MODE

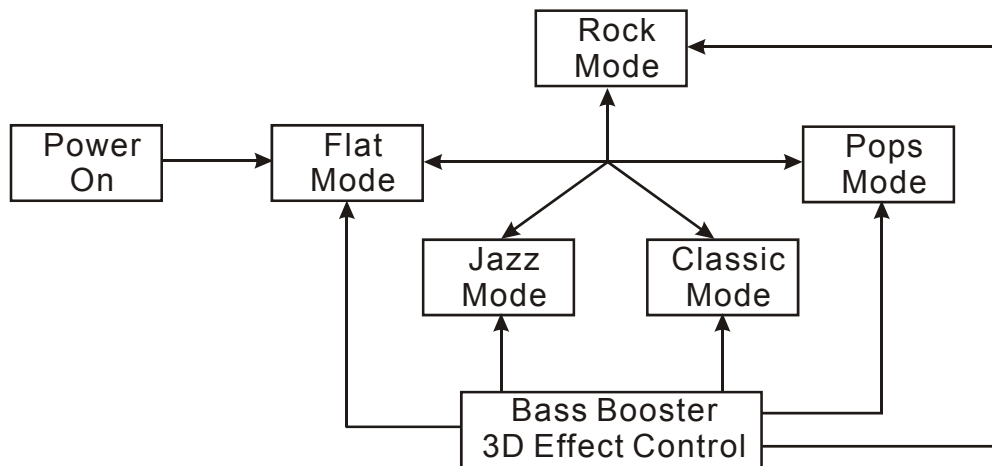

After power on, PT2389 is Flat Mode, under this mode, you can directly select the sound selection you like. The Bass Booster Function and 3D Effect can switch On or Off in any mode.



5-Mode Preset Equalizer IC with Bass Booster & 3D Effect

PT2389

FREQUENCY RESPONSE

The following figures illustrate the various frequency responses under the various sound selections.

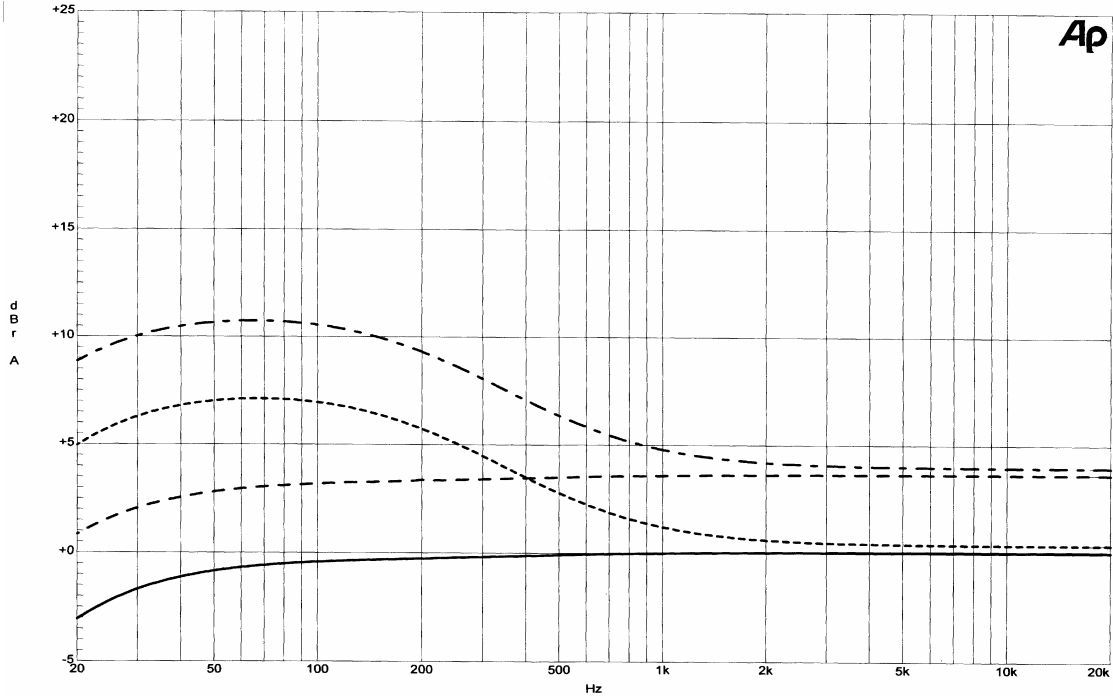

Note:

Flat Mode	Flat+3D	Flat+BB	Flat+3D+BB
—————	- - - - -	- . - .



5-Mode Preset Equalizer IC with Bass Booster & 3D Effect

PT2389

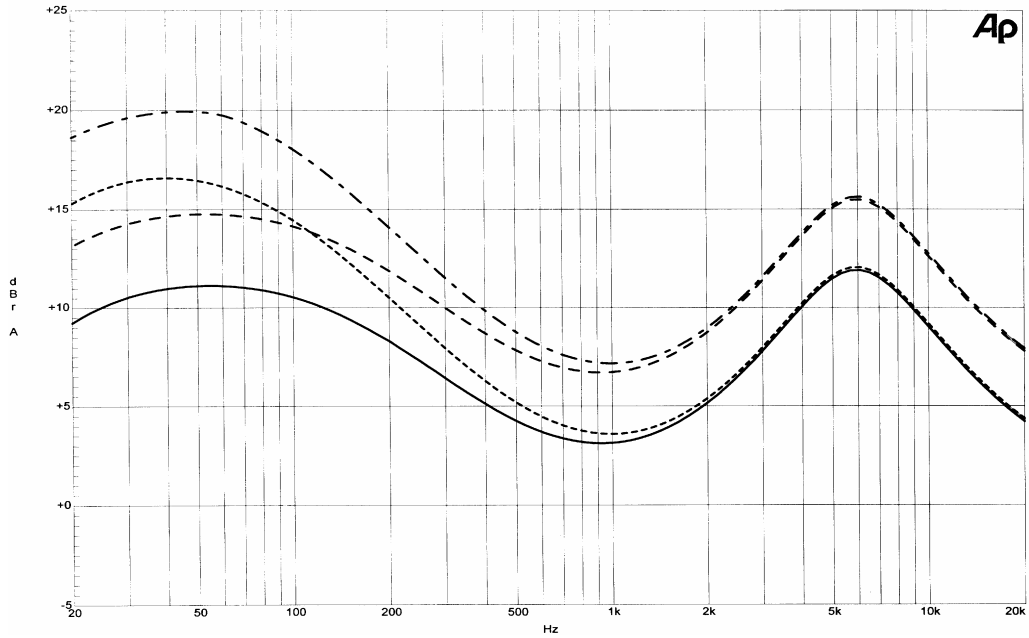

Note:

Rock Mode	Rock+3D	Rock+BB	Rock+3D+BB
—————	-----	- . - .

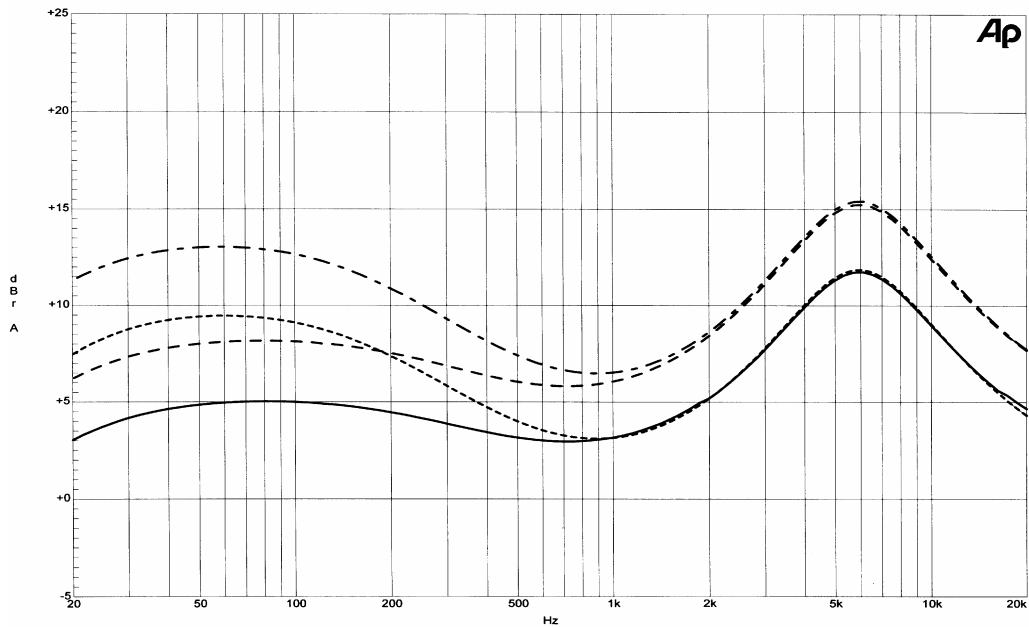

Note:

Pops Mode	Pops+3D	Pops+BB	Pops+3D+BB
—————	-----	- . - .



5-Mode Preset Equalizer IC with Bass Booster & 3D Effect

PT2389

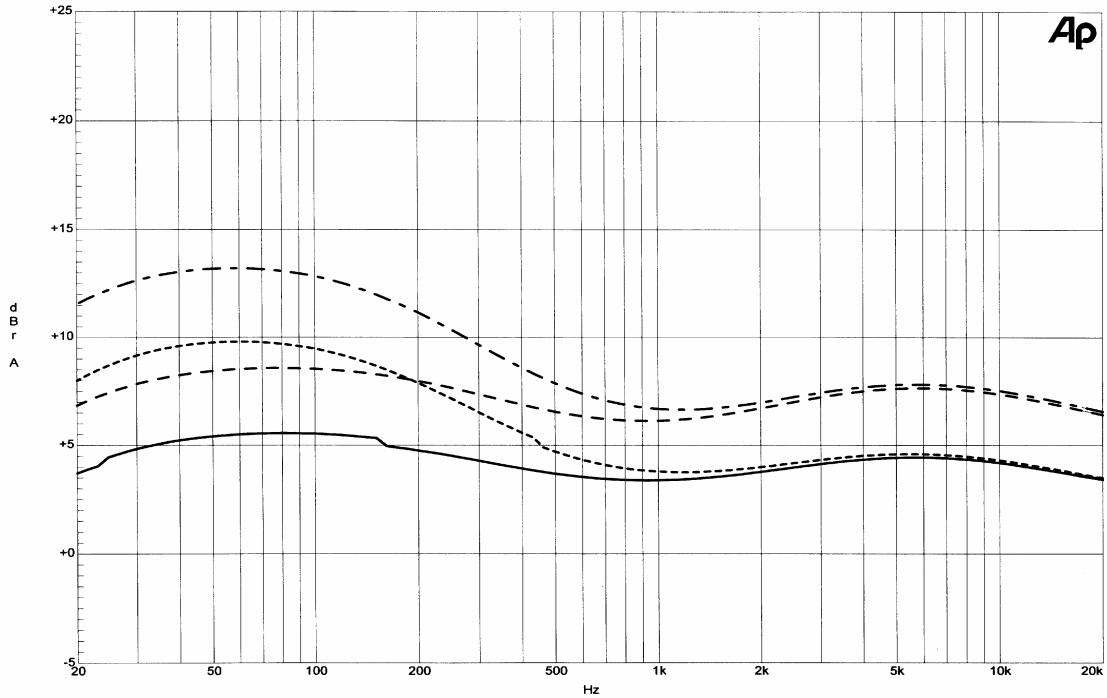

Note:

Classic Mode	Classic+3D	Classic+BB	Classic+3D+BB
—————	-----	- . - .

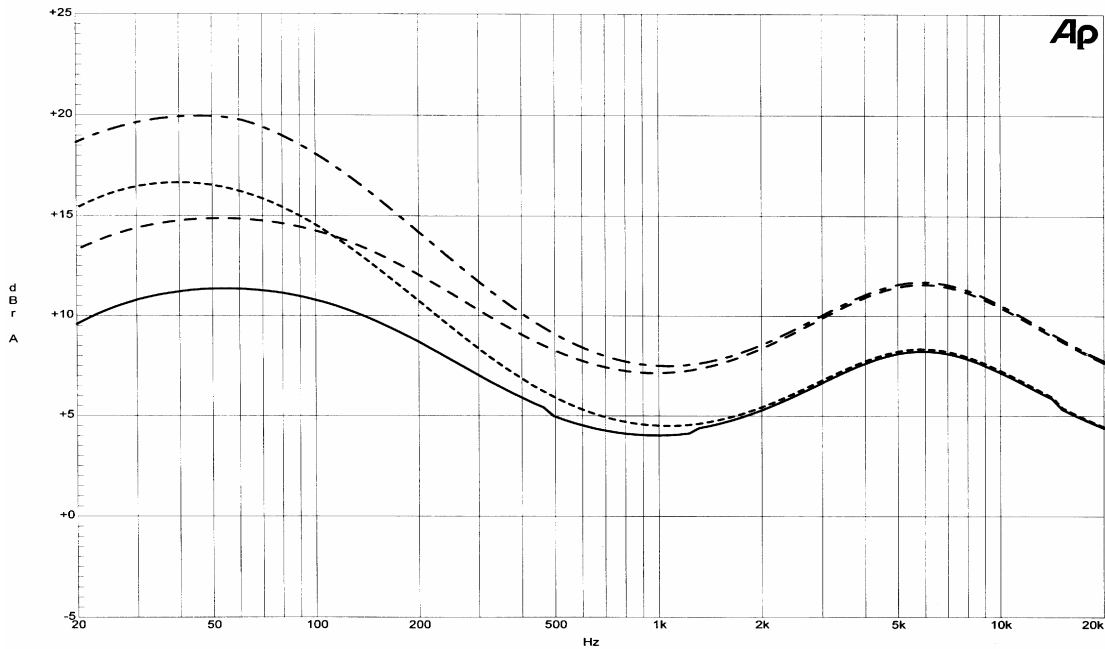

Note:

Jazz Mode	Jazz+3D	Jazz+BB	Jazz+3D+BB
—————	-----	- . - .



5-Mode Preset Equalizer IC with Bass Booster & 3D Effect

PT2389

Different sound selections exhibit different frequency gains and different frequency levels. Please refer to the table below.

Mode	Typ.			Unit
	f=80Hz	f=1KHz	f=10KHz	
Flat	3	3	3	dB
Rock	14	6.5	12.5	
Pops	8	6	12.5	
Classic	8.5	7	7.5	
Jazz	14.5	7.5	10.5	
Flat+Bass Booster	10	5	4	
Rock+Bass Booster	18.5	7	12.5	
Pops+Bass Booster	12.5	6.5	12.5	
Classic+Bass Booster	13	7	8	
Jazz+Bass Booster	18.5	7.5	10.5	
Flat+3D	7	7	7	
Rock+3D	18	10	16	
Pops+3D	11.5	9.5	16	
Classic+3D	12	9.5	11	
Jazz+3D	18	10.5	14	
Flat+BB+3D	14	8.5	7.5	
Rock+ BB+3D	22.5	10.5	16.5	
Pops+ BB+3D	16.5	10	16	
Classic+ BB+3D	16.5	10.5	11	
Jazz+ BB+3D	22.5	11	14	



5-Mode Preset Equalizer IC with Bass Booster & 3D Effect

PT2389

TREBLE AND BASS ADJUSTMENT

It is general knowledge that different individuals have different listening preferences. The application circuit of PT2389 included in this specification has been designed for the taste general listening public; however, you can make the necessary adjustment to suit your personal taste. Please refer to the sections below.

TREBLE ADJUSTMENT

The Treble adjustment is made by changing the value of the 2 capacitors connected between TL -- OUTL pins and TR -- OUTF pins. Please refer to the diagram below.

As the capacitor value becomes bigger, the treble of the gain frequency curve is shifted down. Likewise, as the capacitor value becomes smaller, the treble gain frequency curve shifts the opposite direction. Referring to the diagram above, we see that at 8dB, different capacitor values exhibit different frequency responses. Capacitor value 1800 pF has a lower frequency gain response than 1200 pF capacitor.

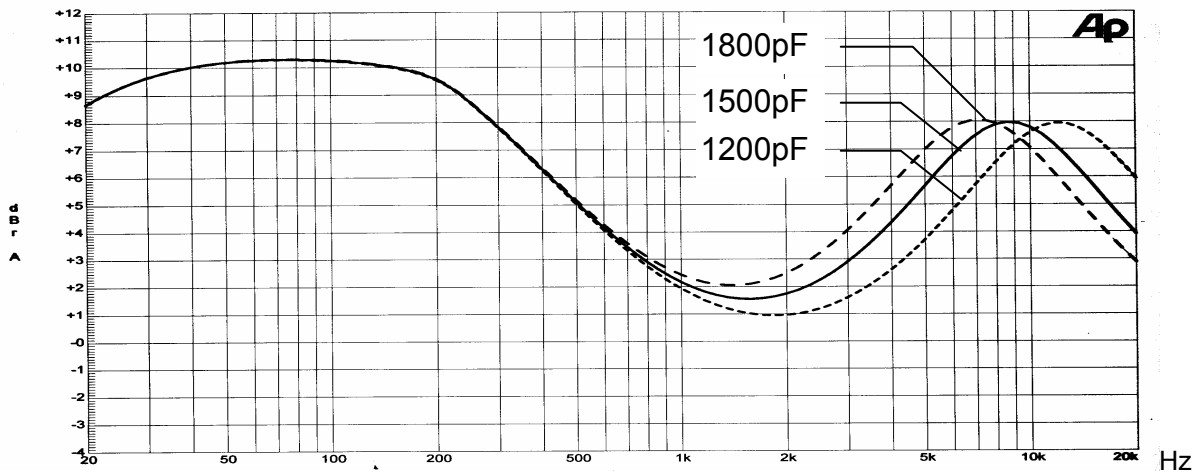

TL – OUTF Capacitors vs. Frequency Response

Note:

.....	————	-----
1200pF	1500pF	1800pF



5-Mode Preset Equalizer IC with Bass Booster & 3D Effect

PT2389

BASS ADJUSTMENT

Bass adjustments can be made by changing the values of the capacitors connected between BL1 -- BL2 pins, and BR1 -- BR2 pins. The larger the capacitor value used, the frequency response curve shifts down. Likewise, the smaller the capacitor value, the frequency response curve shifts the opposite direction. Please refer to the diagram below.

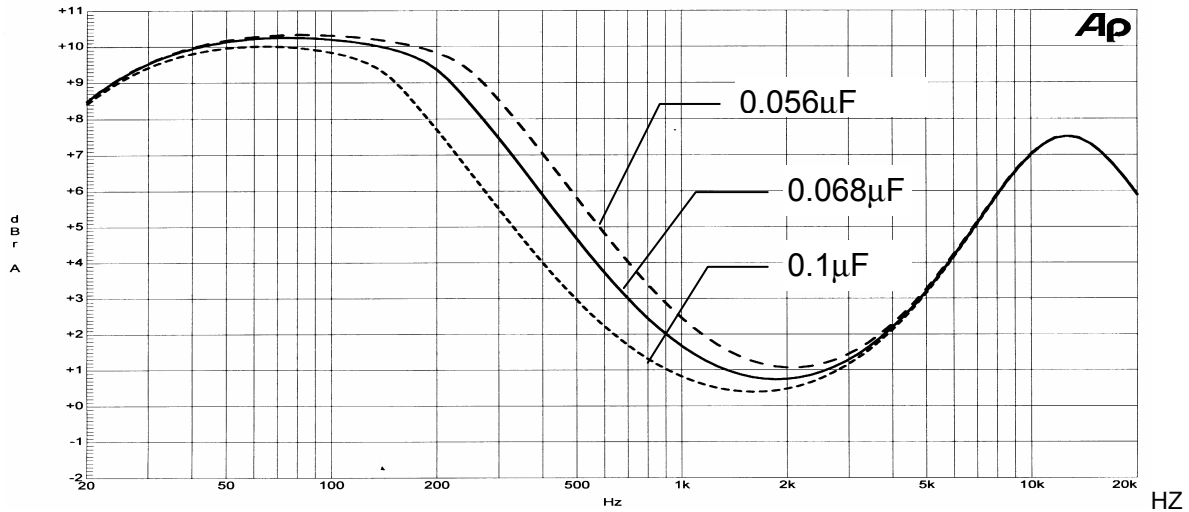

BL1 - BL2 Capacitor vs. Frequency Response Curve

Note:

.....	————	----
0.1µF	0.068µF	0.056µF



5-Mode Preset Equalizer IC with Bass Booster & 3D Effect

PT2389

ABSOLUTE MAXIMUM RATINGS

Parameter	Symbol	Ratings	Unit
Supply voltage	Vcc	12	V
Operating temperature	Topr	-40 ~ +85	°C
Storage temperature	Tstg	-65 ~ +150	°C
Input voltage	Vi	-0.3 ~ Vcc+0.3	V

ELECTRICAL CHARACTERISTICS

(Unless otherwise specified, Vcc=9V, Vi=1Vrms, f=1KHz, Temp=27°C)

Parameter	Symbol	Conditions	Min.	Typ.	Max.	Unit
Operating voltage	Vcc	-	5	9	10	V
Operating current	Icc	Vcc=9V, Vi=0V Flat Mode		20		mA
Max. output voltage	VOM	Vcc=9V			2.5	Vrms
Output noise	VNO	Vcc=9V, Vi=0V BW=20~20KHz A-Weighting		-90	-98	dB
Total harmonic distortion	THD	Vcc=9V, Vi=0.2Vrms BW=20~20KHz			0.01	%
Input impedance	RIN	Vcc=9V	70	100	140	KΩ
Output impedance	ROUT	Vcc=9V		40	80	Ω
High level input voltage	VIH	Vcc=9V			0.7Vcc	V
Low level input voltage	VIL	Vcc=9V	0.3Vcc			V
Max. input voltage	VIMAX	Vcc=9V, Flat Mode, BB & 3D off			2.0	Vrms



5-Mode Preset Equalizer IC with Bass Booster & 3D Effect

PT2389

APPLICATION CIRCUIT
DIRECT KEY MODE

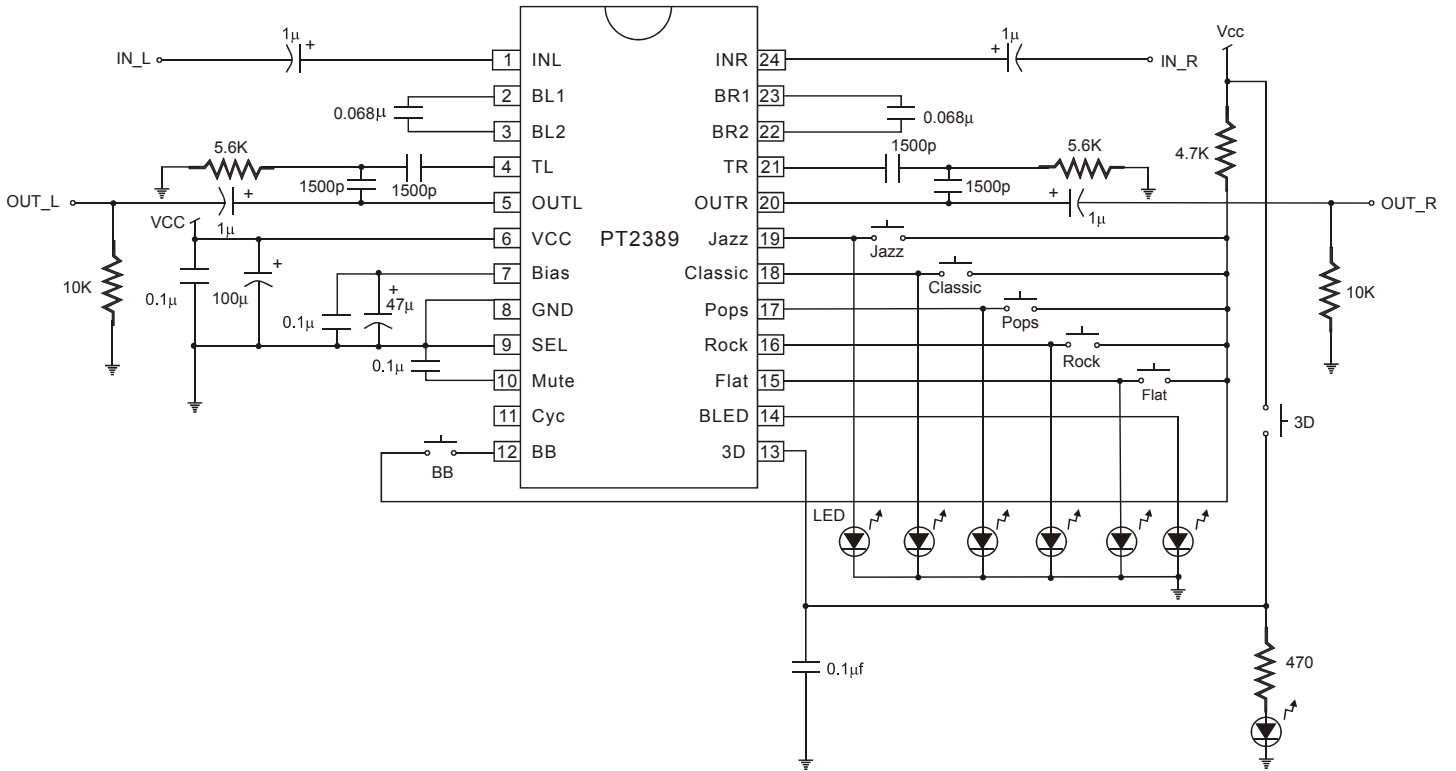

Note: Please use 1500pF, 0.068µF Mylar Capacitor



ORDER INFORMATION

Valid Part Number	Package Type	Top Code
PT2389	24 Pins, DIP, 300mil	PT2389
PT2389-S	24 Pins, SOP, 300mil	PT2389-S
PT2389-SN	24 Pins, SSOP, 150mil	PT2389-SN



5-Mode Preset Equalizer IC with Bass Booster & 3D Effect

PT2389

PACKAGE INFORMATION

24 PINS, DIP, 300MIL

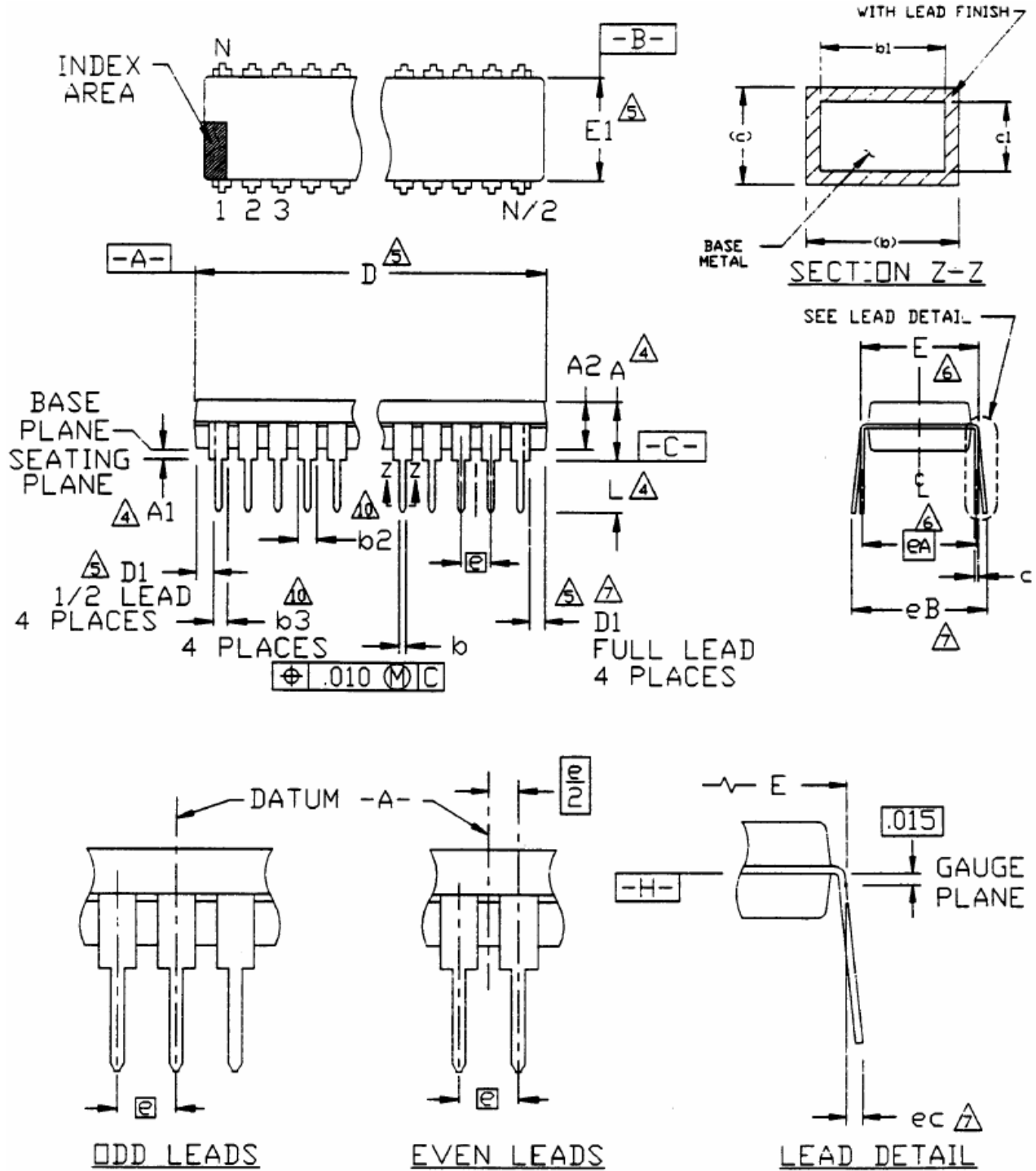



5-Mode Preset Equalizer IC with Bass Booster & 3D Effect

PT2389

Symbols	Min.	Nom.	Max.
A			0.210
A1	0.015		
A2	0.115	0.130	0.195
b	0.014	0.018	0.022
b1	0.014	0.018	0.020
b2	0.045	0.060	0.070
b3	0.030	0.039	0.045
c	0.008	0.010	0.014
c1	0.008	0.010	0.011
D	1.160	1.185	1.195
D1	0.005		
E	0.300	0.310	0.325
E1	0.240	0.250	0.280
e	0.100 bsc.		
eA	0.300 bsc.		
eB			0.430
eC	0.000		0.060
L	0.115	0.130	0.150

Notes:

- All dimensions are in INCHES.
- Dimensioning and tolerancing per ANSI Y 14.5-1982.
- Dimension "A", "A1" and "L" are measured with the package seated in JEDEC Seating Plane Gauge GS-3.
- "D", "D1" and "E1" dimensions do not include mold flash or protrusions. Mold flash or protrusions shall not exceed 0.010 inch.
- "E" and "eA" measured with the leads constrained to be perpendicular to datum C.
- "eB" and "eC" are measured at the lead tips with the leads unconstrained.
- N is the number of terminal positions. (N=24)
- Pointed or rounded lead tips are preferred to ease insertion.
- "b2" and "b3" maximum dimensions are not include dambar protrusions. Dambar protrusions shall not exceed 0.010 inch (0.25mm)
- Distance between leads including Dambar protrusions to be 0.005 inch. minimum.
- Datum plane H coincident with the bottom of lead, where lead exits body.
- Refer to JEDEC MS-001, Variation BE.

JEDEC is the trademark of JEDEC SOLID STATE TECHNOLOGY ASSOCIATION.



5-Mode Preset Equalizer IC with Bass Booster & 3D Effect

PT2389

24 PINS, SOP, 300MIL

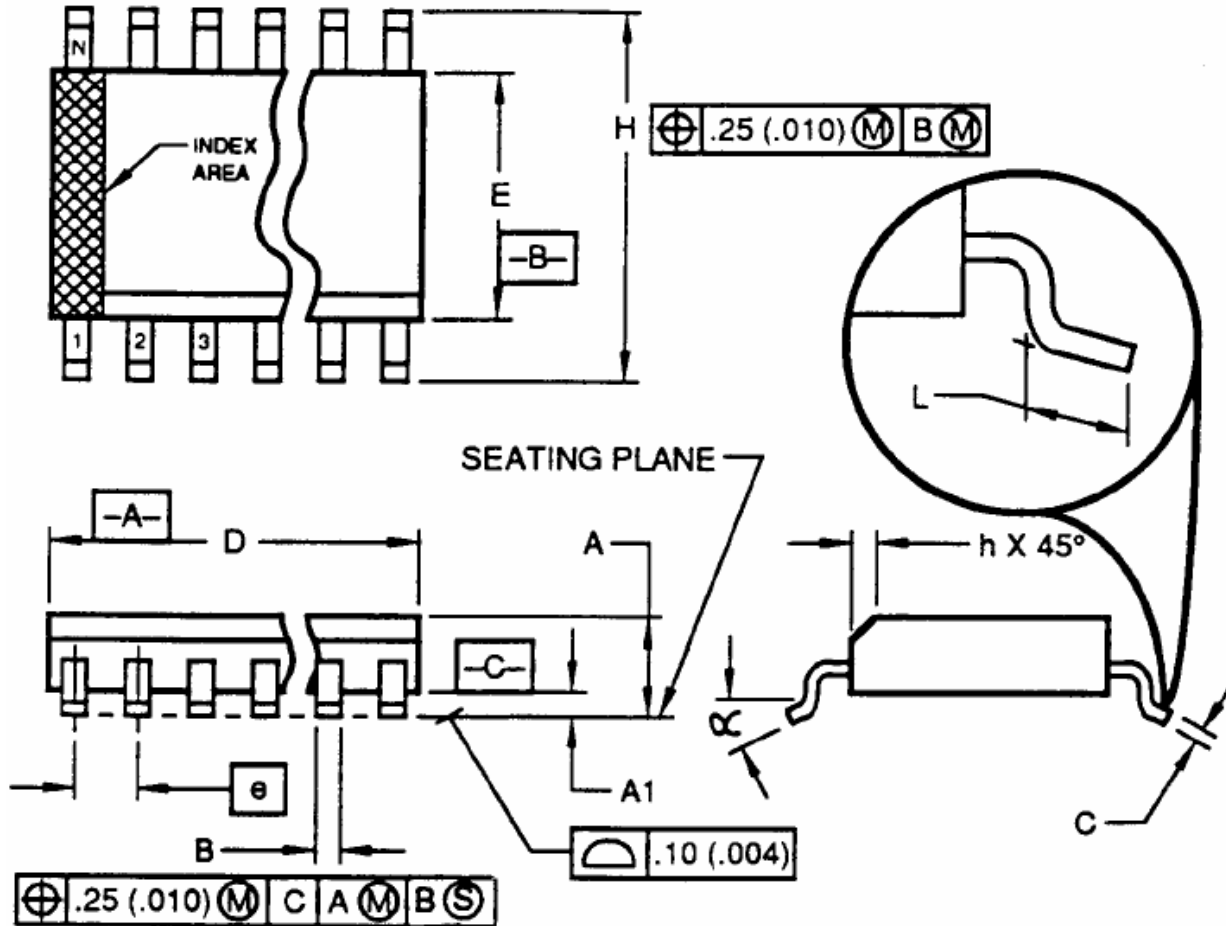

Symbols	Min.	Nom.	Max.
A	2.35		2.65
A1	0.10		0.30
B	0.33		0.51
C	0.23		0.32
D	15.20		15.60
E	7.40		7.60
e	1.27 bsc.		
H	10.00		10.65
h	0.25		0.75
L	0.40		1.27
α	0°		8°



5-Mode Preset Equalizer IC with Bass Booster & 3D Effect

PT2389

Notes:

1. Dimensioning and tolerancing per ANSI Y 14.5-1982.
2. Dimension "D" does not include mold flash, protrusions or gate burrs. Mold Flash, protrusion or gate burrs shall not exceed 0.15mm (0.006 in) per side.
3. Dimension "E" does not include interlead flash protrusions. Interlead flash or protrusions shall not exceed 0.25 mm (0.010 in) per side.
4. The chamfer on the body is optional. It is not present, a visual index feature must be located within the crosshatched area.
5. "L" is the length of the terminal for soldering to a substrate.
6. "N" is the number of terminal position. (N=24)
7. The lead width "B" as measured 0.36 mm (0.014 in) or greater above the seating plane, shall not exceed a maximum value of 0.61mm (0.24 in).
8. Controlling dimension: MILLIMETER.
9. Refer to JEDEC MS-013, Variation AD.

JEDEC is the trademark of JEDEC SOLID STATE TECHNOLOGY ASSOCIATION.



5-Mode Preset Equalizer IC with Bass Booster & 3D Effect

PT2389

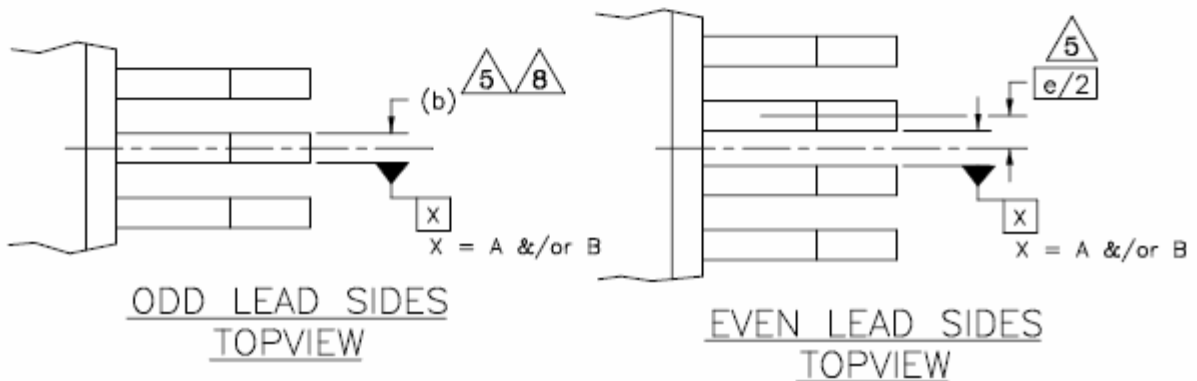
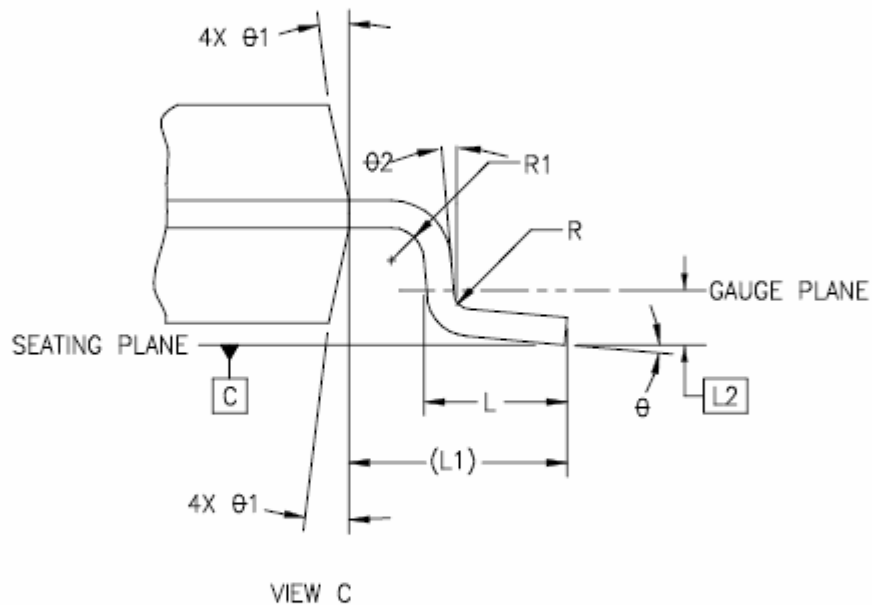
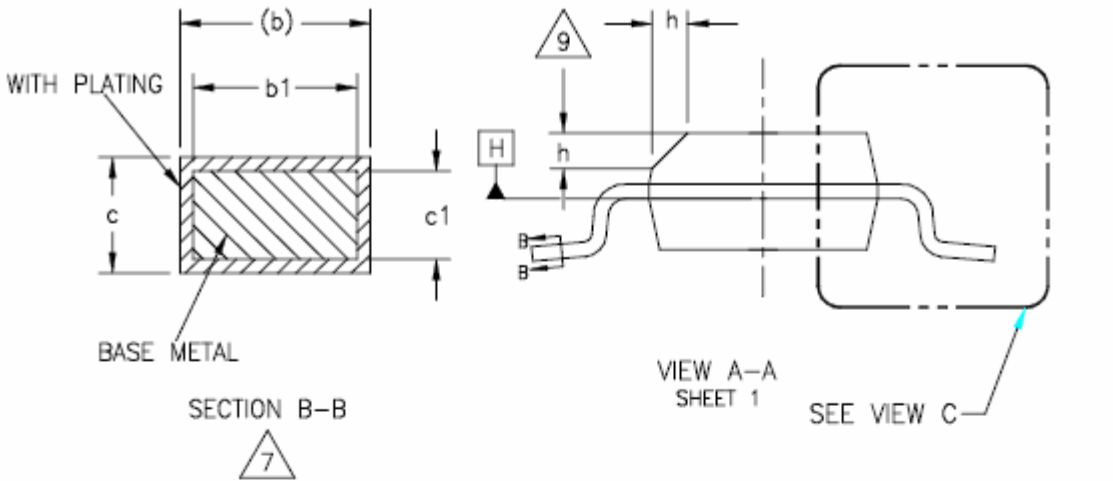



5-Mode Preset Equalizer IC with Bass Booster & 3D Effect

PT2389

Symbol	Min.	Nom.	Max.
A	0.053	-	0.069
A1	0.004	-	0.010
A2	0.049	-	0.065
b	0.008	-	0.012
b1	0.008	0.010	0.011
c	0.006	-	0.010
c1	0.006	0.008	0.009
D	0.341 BSC.		
E	0.236 BSC.		
E1	0.154 BSC.		
e	0.025 BAS.		
L	0.016	-	0.050
L1	0.041 REF.		
L2	0.010 BAS.		
R	0.003	-	-
R1	0.003	-	-
θ	0°	-	8°
$\theta 1$	5°	-	15°
$\theta 2$	0°	-	-
aaa	0.004		
bbb	0.008		
ccc	0.004		
ddd	0.007		
eee	0.004		



5-Mode Preset Equalizer IC with Bass Booster & 3D Effect

PT2389

Notes:

1. Dimensioning and tolerancing per ANSI Y14.5M-1982.
2. Dimensions in inches (angles in degrees)
3. Dimension D does not include mold flash, protrusions or gate burrs. Mold flash, protrusions or gate burrs shall not exceed 0.006" per end. Dimension E1 does not include interlead flash or protrusions. Interlead flash or protrusions shall not exceed "0.006" per side. D1 and E1 dimensions are determined at datum H.
4. The package top may be smaller than the package bottom. Dimensions D and E1 are determined at the outermost extremes of the plastic body exclusive of mold flash, tie bar burrs, gate burrs and interlead flash, but including any mismatch between the top and bottom of the plastic.
5. Datums A and B to be determined at datum H.
6. N is the maximum number of terminal position. (N=24)
7. The dimensions apply to the flat section of the lead between 0.004 to 0.010 inches from the lead tip.
8. Dimension b does not include dambar protrusion. Allowable dambar protrusion shall be 0.004" total in excess of b dimension at maximum material condition. The dambar can not be located on the lower radius of the foot.
9. Refer to JEDEC MO-137 variation AE.

JEDEC is the registered trademark of JEDEC SOLID STATE TECHNOLOGY ASSOCIATION