

DESCRIPTION

The PT2812 is an integrated 3W stereo Class-D amplifier with audio processor. The input selector supports 2 Single-Ended and 1 Fully-Differential input can be chose. The highly integration of the audio processor and class-D amplifier can further reduce external components BOM and provides better audio experience. All of functions are controlled via I2C bus.

APPLICATIONS

- PC/Video Projector
- Portable media player
- Audio duck system
- Flat panel display with audio inputs

FEATURES

- Supply Voltage: 3~6V
- 3W X 2 Class-D power amplifier (VDD=5V, RL=4Ω)
- 1 Fully-Differential input
- 2 Single-Ended audio inputs
- Programmable input gain from 0 to +15dB
- Master volume in 1dB/step from 0 to -79dB
- Advanced soft-mute and multiple soft-step volume technology eliminate audible click during volume and input sources changing.
- Built-in RF noise filter
- Shutdown function for power saving
- Over temperature and over current protection
- Controlled by I²C interface
- Available in 32 Pins, 4x4 mm QFN package

BLOCK DIAGRAM

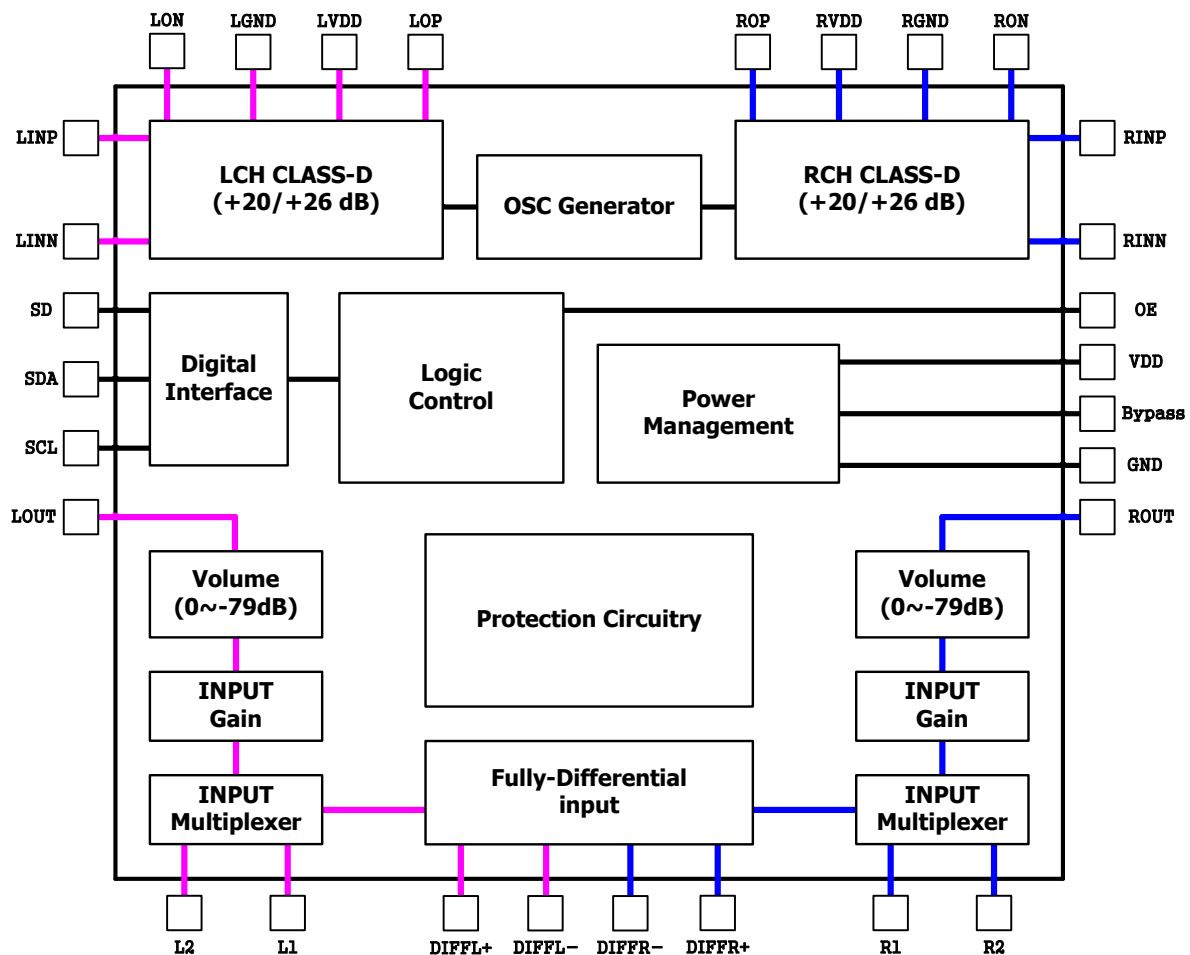

APPLICATION CIRCUIT

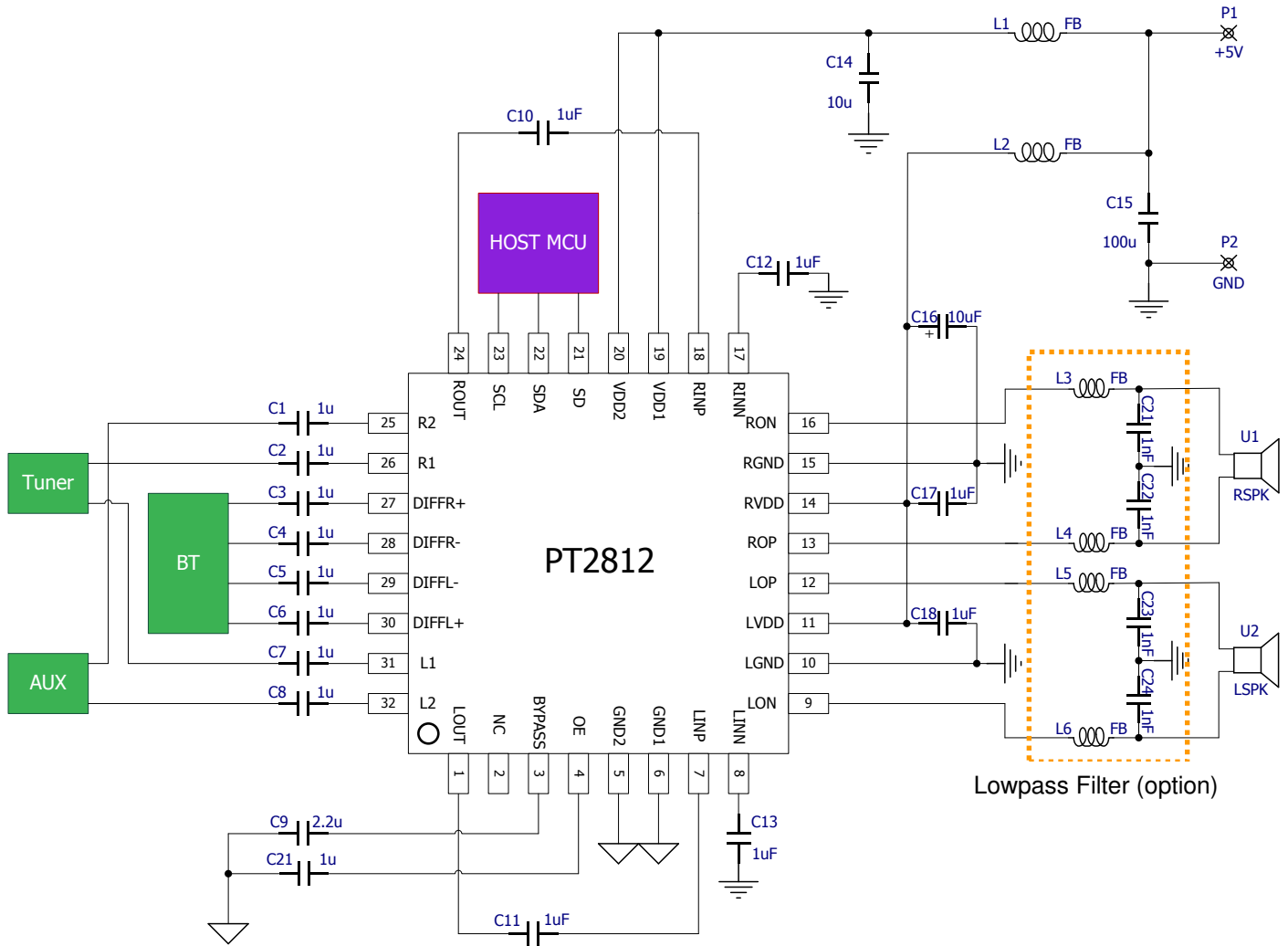

ORDER INFORMATION

Valid Part Number	Package Type	Top Code
PT2812-QFN	32 Pins, QFP, 4 X 4 mm	PT2812-QFN

PIN CONFIGURATION

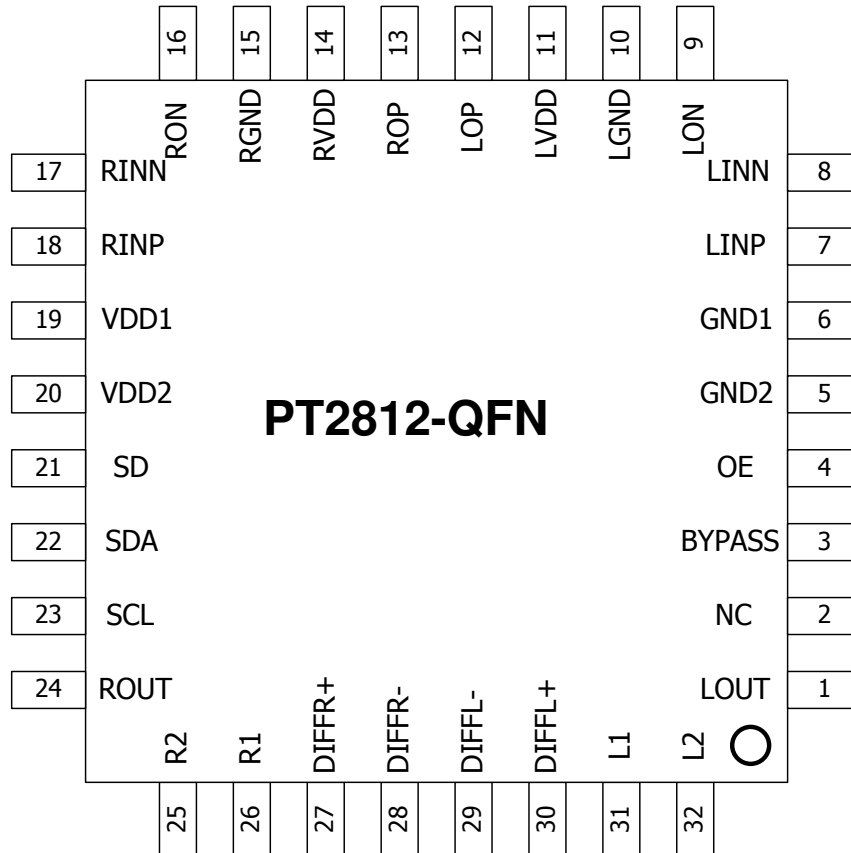

PIN DESCRIPTION

Pin Name	I/O	Description	Pin No.
LOUT	O	Left channel line out	1
NC	-	No connection	2
BYPASS	P	Bypass cap for Internal Voltage Reference, a 2.2 μ F cap is recommended.	3
OE	I	Output Enable setting, connect a 0.22 μ F cap to GND.	4
GND1	P	Ground for internal circuits	5
GND2	P	Ground for internal circuits	6
LINP	I	Positive input of left channel Class-D amp	7
LINN	I	Negative input of left channel Class-D amp	8
LON	O	Negative output of left channel Class-D amp	9
LGND	P	Power ground of left channel Class-D amp	10
LVDD	P	Power input of left channel Class-D amp	11
LOP	O	Positive output of left channel Class-D amp	12
ROP	O	Positive output of right channel Class-D amp	13
RVDD	P	Power input of right channel Class-D amp	14
RGND	P	Power ground of right channel Class-D amp	15
RON	O	Negative output of right channel Class-D amp	16
RINN	I	Negative input of right channel Class-D amp	17
RINP	I	Positive input of right channel Class-D amp	18
VDD1	P	Power input for internal circuits	19
VDD2	P	Power input for internal circuits	20
SD	I	Shutdown. Sets to low level will turn off whole chip and pull up to High level is back to normal operation.	21
SDA	I	I ² C bus data input	22
SCL	I	I ² C bus clock input	23
ROUT	O	Right channel line out	24
R2	I	Input 2 of right channel	25
R1	I	Input 1 of right channel	26
DIFFR+	I	Differential right channel "+" input	27
DIFFR-	I	Differential right channel "-" input	28
DIFFL-	I	Differential left channel "-" input	29
DIFFL+	I	Differential left channel "+" input	30
L1	I	Input 1 of left channel	31
L2	I	Input 2 of left channel	32

IMPORTANT NOTICE

Princeton Technology Corporation (PTC) reserves the right to make corrections, modifications, enhancements, improvements, and other changes to its products and to discontinue any product without notice at any time.

PTC cannot assume responsibility for use of any circuitry other than circuitry entirely embodied in a PTC product. No circuit patent licenses are implied.

Princeton Technology Corp.
2F, 233-1, Baociao Road,
Sindian Dist., New Taipei City 23145, Taiwan
Tel: 886-2-66296288
Fax: 886-2-29174598
<http://www.princeton.com.tw>