

## DESCRIPTION

The PT2830 is an integrated audio amplifier design for the compact audio system; the maximum output power is up to 10W x 2. Utilizing PTC exclusive, patented Class-D modulation circuit, compare with traditional Class-AB amplifier, the PT2830 have a lot of benefit for high efficiency, low heat dissipation and very low harmonic distortion.

Thanks for highly integrated design, consist a complete audio amplifier system is easy and only needs few external components, no more complex PCB wiring and saving the PCB sizes.

## FEATURES

- 10W/8Ω (THD=10%) × 2 output power
- 4 stereo sources input
- Volume, bass and treble control
- Audio line out for second power amplifier
- Built-in 5V regulator
- Improved RF interference immunity
- 4 power amplifier voltage gain selectable
- External mute output
- Low harmonic distortion (0.05%), superior sound quality
- I2C bus controls
- Over current and temperature protection
- Low EMI emission
- 48 Pins, E-LQFP ( thermal pad included) package

## APPLICATIONS

- LCD TV
- Docking Speaker System
- Other audio applications

## BLOCK DIAGRAM

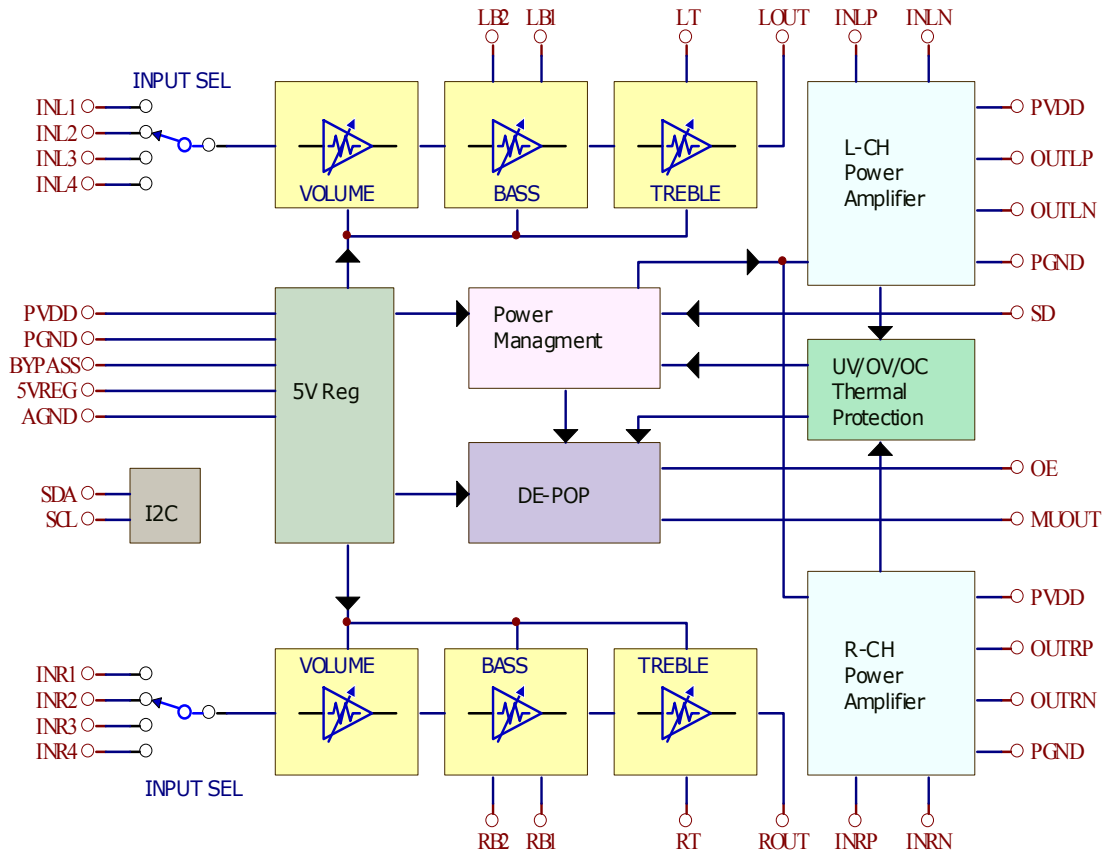



# APPLICATION CIRCUIT

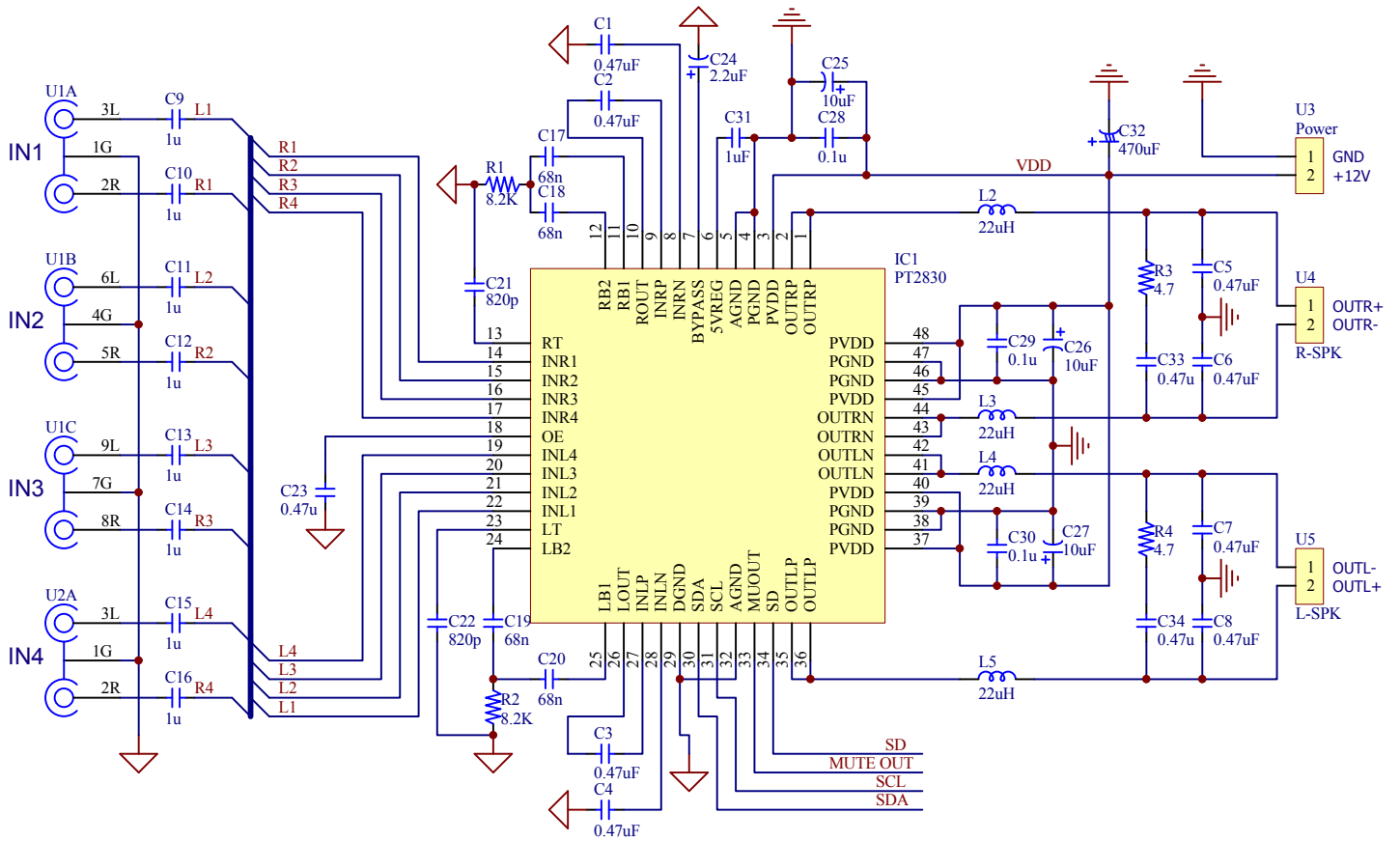



## ORDER INFORMATION

Valid Part Number	Package Type	Top Code
PT2830-LQ	48 Pins, E-LQFP, 7 X 7 mm	PT2830-LQ

## PIN CONFIGURATION

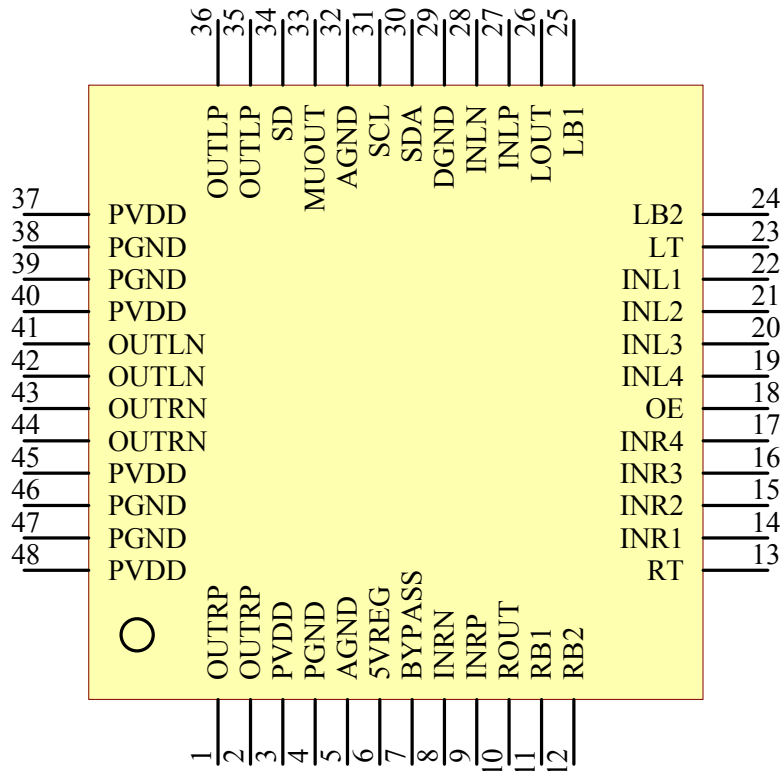



## PIN DESCRIPTION

Pin Name	I/O	Description	Pin No.
OUTRP	O	Right channel output (+)	1
OUTRP	O	Right channel output (+)	2
PVDD	Power	Power supply of control circuit	3
PGND	Power	Ground of control circuit	4
AGND	Power	Ground of analog circuit	5
5VREG	O	Regulator bypass	6
BYPASS	I	Internal voltage reference bypassing	7
INRN	I	Power amp right channel input (-)	8
INRP	I	Power amp right channel input (+)	9
ROUT	O	Right channel line out	10
RB1	I	Capacitor 1 for right channel bass controller	11
RB2	I	Capacitor 2 for right channel bass controller	12
RT	I	Capacitor for right channel treble controller	13
INR1	I	Input 1 of right channel	14
INR2	I	Input 2 of right channel	15
INR3	I	Input 3 of right channel	16
INR4	I	Input 4 of right channel	17
OE	I/O	Output Enable, with internal high resistance pull-up, usually connects a cap to ground for turn-on delay.	18
INL4	I	Input 4 of left channel	19
INL3	I	Input 3 of left channel	20
INL2	I	Input 2 of left channel	21
INL1	I	Input 1 of left channel	22
LT	I	Capacitor for left channel treble controller	23
LB2	I	Capacitor 2 for left channel bass controller	24
LB1	I	Capacitor 1 for left channel bass controller	25
LOUT	O	Left channel line out	26
INLP	I	Power amp left channel input (+)	27
INLN	I	Power amp left channel input (-)	28
DGND	Power	Digital GND for I2C Ack.	29
SDA	I/O	I <sup>2</sup> C bus data Input	30
SCL	I	I <sup>2</sup> C bus clock Input	31
AGND	Power	Ground of analog circuit	32
MUOUT	O	External mute output	33
SD	I	Shutdown. Sets to low level will turn off whole chip and pull up to High level for normal operation.	34
OUTLP	O	Left channel output (+)	35
OUTLP	O	Left channel output (+)	36
PVDD	Power	Left channel power supply input	37
PGND	Power	Left channel power ground	38
PGND	Power	Left channel power ground	39
PVDD	Power	Left channel power supply input	40
OUTLN	O	Left channel output (-)	41
OUTLN	O	Left channel output (-)	42
OUTRN	O	Right channel output (-)	43
OUTRN	O	Right channel output (-)	44
PVDD	Power	Right channel power supply input	45
PGND	Power	Right channel power ground	46
PGND	Power	Right channel power ground	47
PVDD	Power	Right channel power supply input	48

## **IMPORTANT NOTICE**

Princeton Technology Corporation (PTC) reserves the right to make corrections, modifications, enhancements, improvements, and other changes to its products and to discontinue any product without notice at any time.

PTC cannot assume responsibility for use of any circuitry other than circuitry entirely embodied in a PTC product. No circuit patent licenses are implied.

Princeton Technology Corp.  
2F, 233-1, Baociao Road,  
Sindian, Taipei 23145, Taiwan  
Tel: 886-2-66296288  
Fax: 886-2-29174598  
<http://www.princeton.com.tw>