



DESCRIPTION

PT2253A is an electronic volume controller IC utilizing CMOS Technology specially designed for use on audio equipments. It has two (2) built-in channels making it ideally suitable for mono and stereo sound applications. PT2253A provides a wide frequency response range and a very low harmonic distortion to mention a few; thereby guaranteeing a highly effective and reliable performance.

FEATURES

- CMOS technology
- Low power consumption
- Operating voltage range: $V_{cc}=6 \sim 12V$
(Backup voltage is up to 4V)
- 0dB to -68dB attenuation controlled by 2dB/step
- 2 channels in each chip
- Capable to control attenuation by a built-in oscillator and Up/Down pin
- Single power supply or dual power supplies of (+) and (-) can be used
- Wide frequency response range
- Very low harmonic distortion
- Available in 16 pin, DIP package

APPLICATIONS

- Audio Equipment Volume Control
- Traditional VR Replacement



Electronic Volume Controller IC

PT2253A

BLOCK DIAGRAM

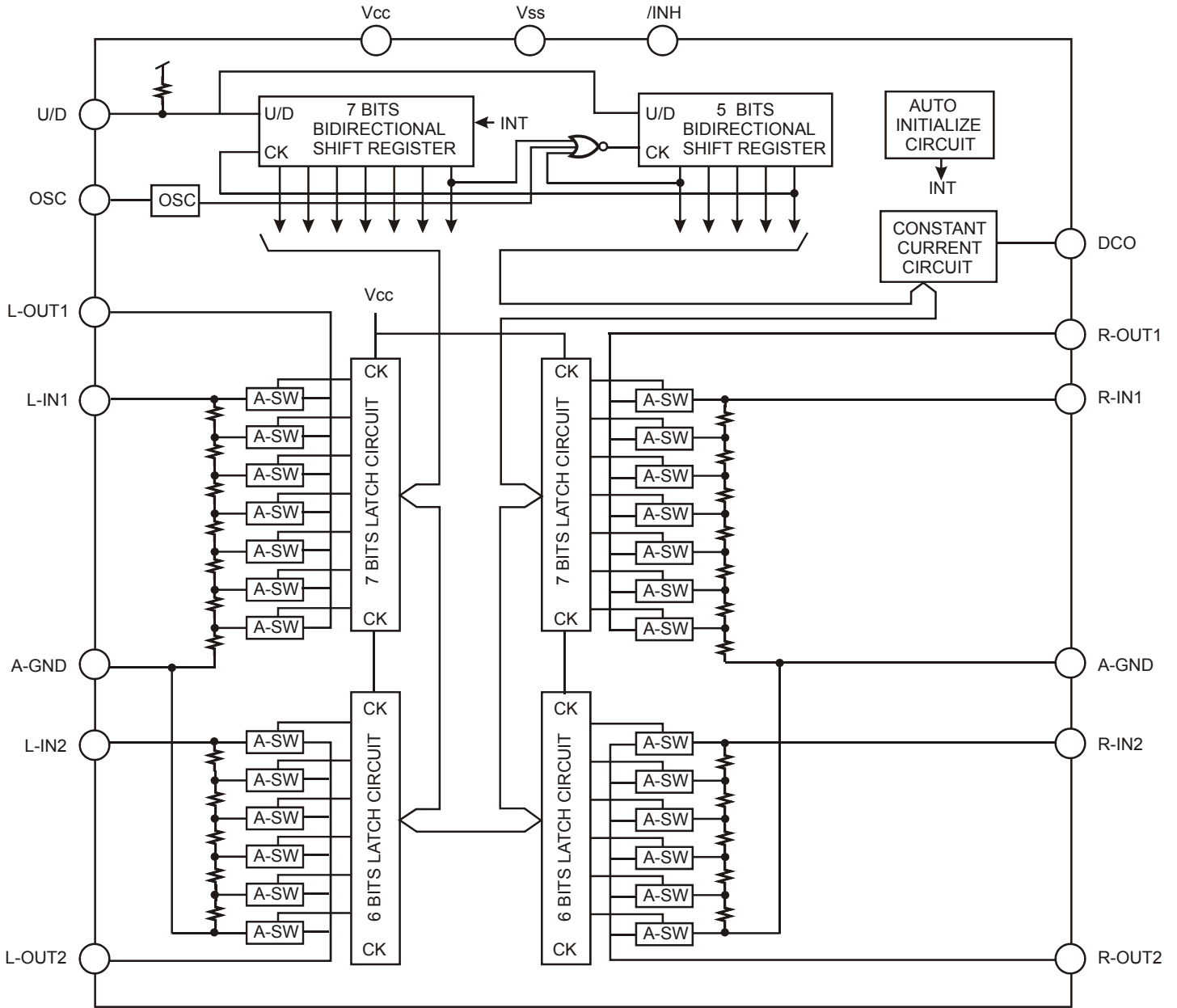



Electronic Volume Controller IC

PT2253A

PIN CONFIGURATION

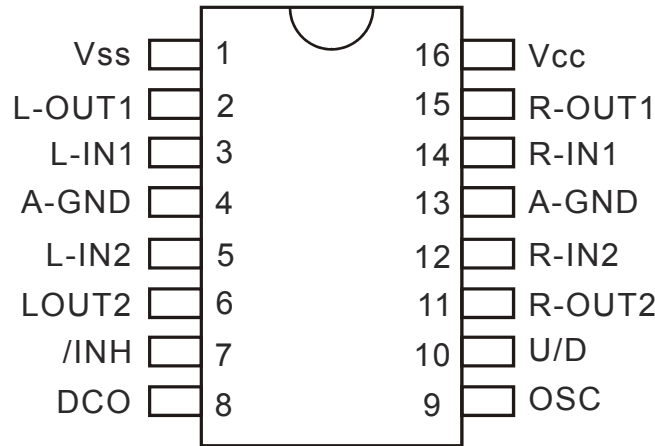

PT2253A

PIN DESCRIPTION

Pin Name	I/O	Description	Pin No.
Vss	Power	Negative Power Supply	1
L-OUT1	O	10dB/Step Attenuator Output A signal applied to 'IN' is attenuated into 7 steps from 0dB to -60dB.	2
L-IN1	I	10dB/Step Attenuator Input	3
A-GND	GND	Analog Ground Pin	4
L-IN2	I	2dB/Step Attenuator Input	5
L-OUT2	O	2dB/Step Attenuator Output A signal applied to "IN" is attenuated into 5 steps from 0dB to -8dB.	6
/INH	I	Inhibit Terminal. At "L" level, all inputs and outputs are disabled. At "H" level, operation is normal.	7
DCO	O	DC Current Output Pin	8
OSC	I/O	RC Connecting Pin for the Oscillator	9
U/D	I	Attenuator Up/Down Control Pin	10
R-OUT2	O	2dB/Step Attenuator Output, same as L-OUT2.	11
R-IN2	I	2dB/Step Attenuator Input, same as L-IN2.	12
A-GND	GND	Analog Ground Pin	13
R-IN1	I	10dB/Step Attenuator Input, same as L-IN1.	14
R-OUT1	O	10dB/Step Attenuator Output, same as L-OUT1.	15
Vcc	Power	Positive Power Supply	16



FUNCTION DESCRIPTION

ATTENUATION SETTING

The Attenuation can be increased or decreased depending on the state of the U/D Pin (either “H” or “L” Level) by actuating the built-in oscillator. When power is applied, the attenuation is automatically set at -40dB.

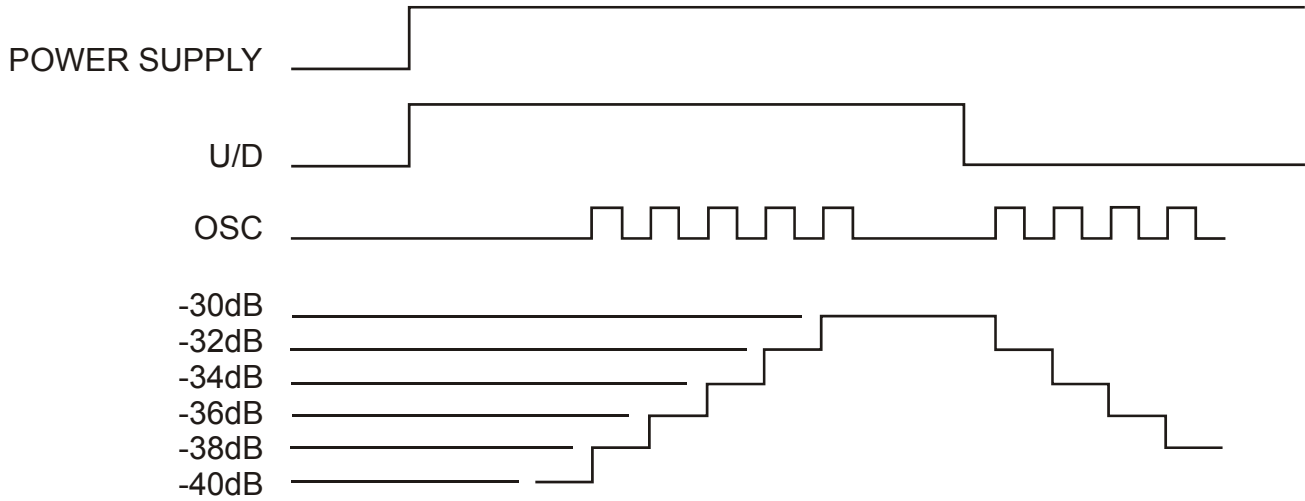

When the DOWN Key is pressed, the U/D Pin goes to the “L” Level and the oscillator is actuated in the down state. Thus, attenuation is increased.

Conversely, when the UP Key is pressed, the U/D Pin goes to the “H” Level and the oscillator is actuated in the up state. Thus, attenuation is decreased.

Oscillation frequency (f_{osc}) is dependent on the C_x and the R_x and is determined by the following equation:

$$f_{osc} = \frac{1}{0.7 (C_x)(R_x)} \text{ Hz}$$

where: $R_s \geq 3R_x$



Electronic Volume Controller IC

PT2253A

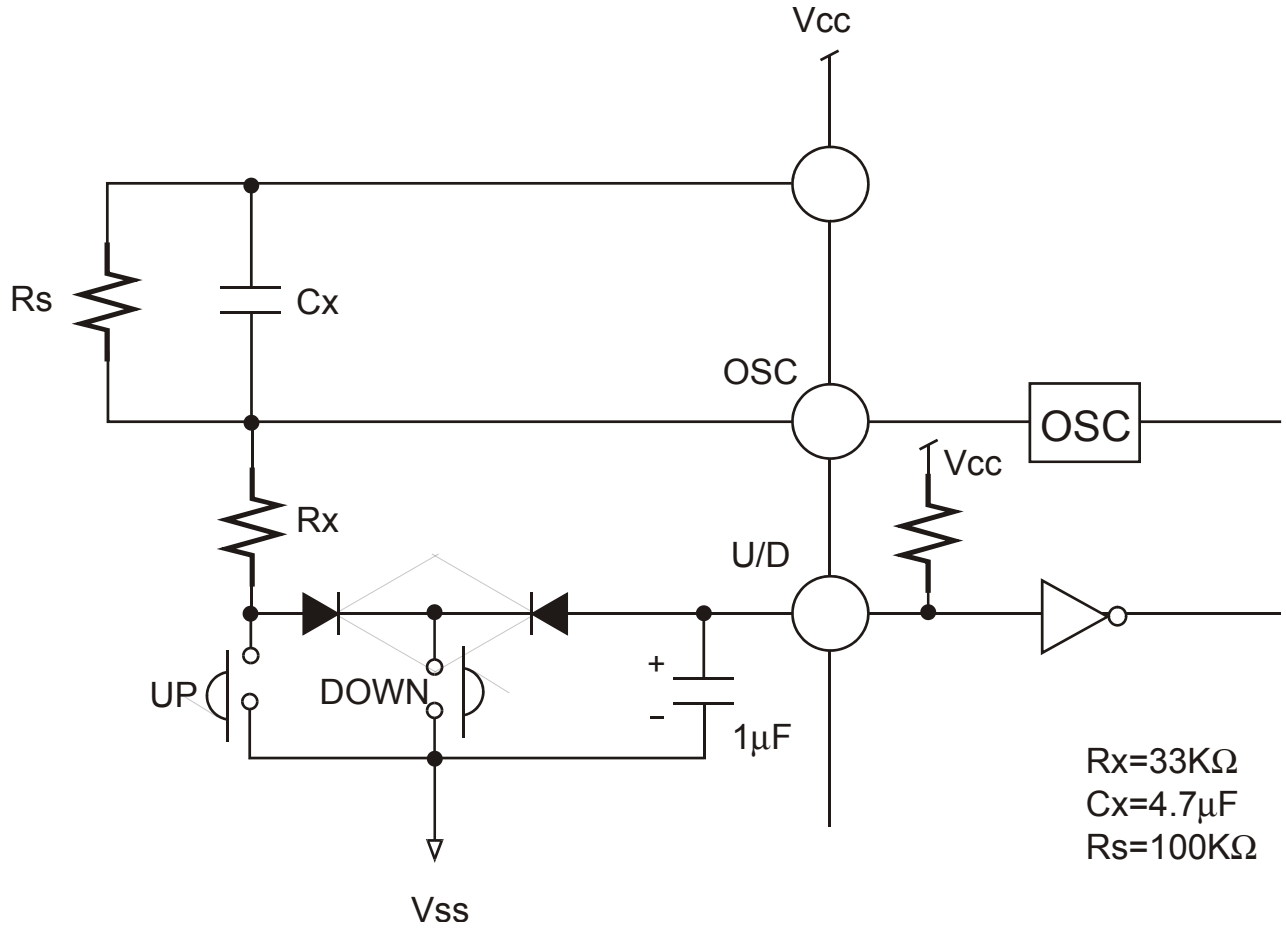



Electronic Volume Controller IC

PT2253A

ATTENUATION DISPLAY OUTPUT

PT2253A has a DC Current Output Pin (DCO). The output level is divided into 13 steps. Please refer to the table below:

Step	DCO	Attenuation
0	0	-64dB ~ ∞
1	1I	-60dB ~ -62dB
2	2I	-54dB ~ -58dB
3	3I	-50dB ~ -52dB
4	4I	-44dB ~ -48dB
5	5I	-40dB ~ -42dB
6	6I	-34dB ~ -38dB
7	7I	-30dB ~ -32dB
8	8I	-24dB ~ -28dB
9	9I	-20dB ~ -22dB
10	10I	-14dB ~ -18dB
11	11I	-10dB ~ -12dB
12	12I	-4dB ~ -8dB
13	13I	0dB ~ -2dB

Current value may fluctuate depending on the IC. When high precision is required, use a variable resistor as a load resistor.

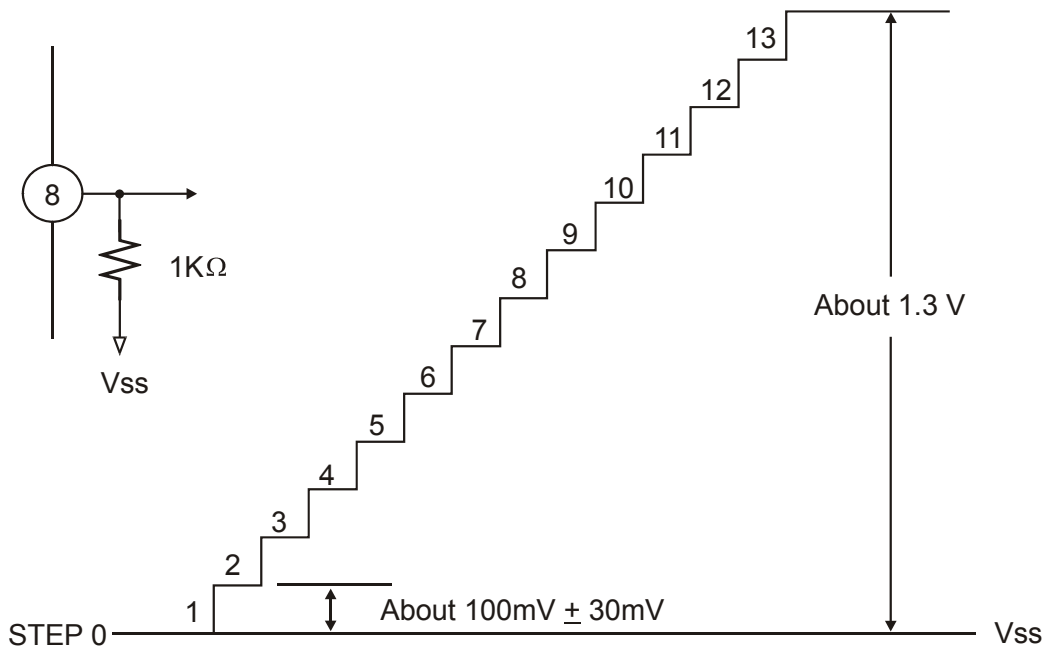



Electronic Volume Controller IC

PT2253A

ATTENUATOR

Attenuator 1 attenuates 0 ~ -60dB at 10dB/step.

Attenuator 2 attenuates 0 ~ -8dB at 2dB/step.

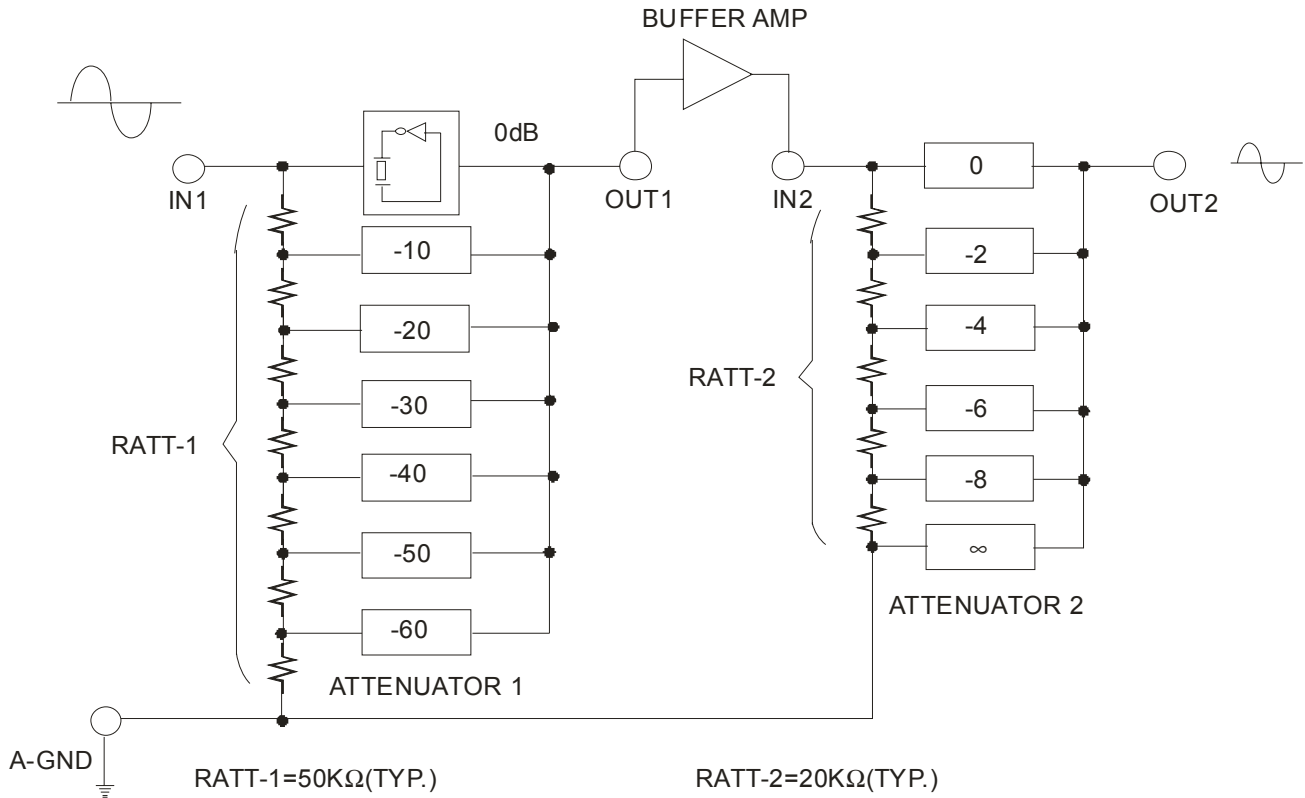

If there is the possibility of excessive voltage in the attenuator, it is recommended that a protective diode be inserted. Please refer to the diagram below.

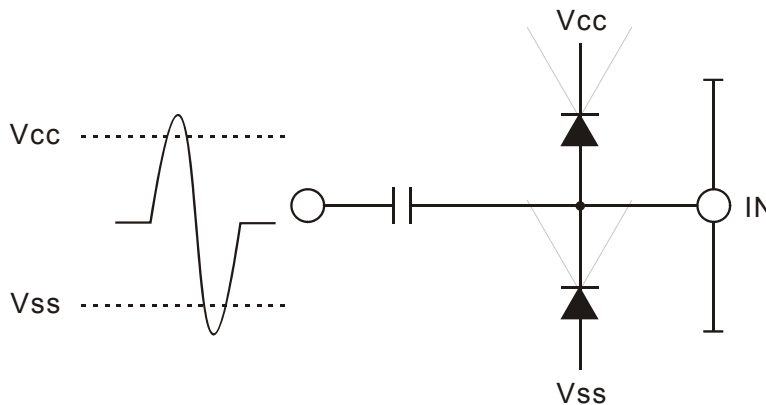



Electronic Volume Controller IC

PT2253A

POWER SUPPLY

DUAL POWER SUPPLY

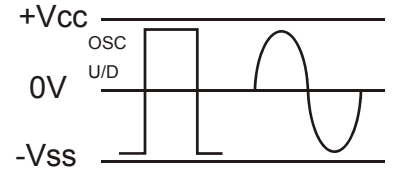
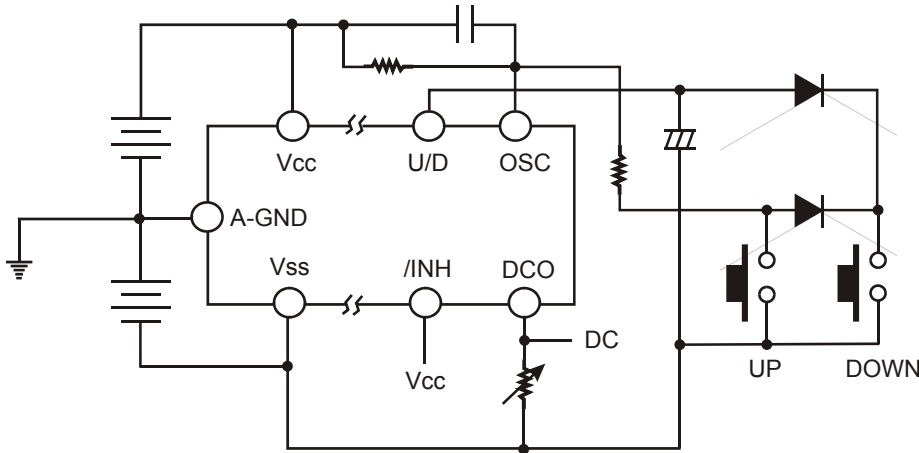

SINGLE POWER SUPPLY

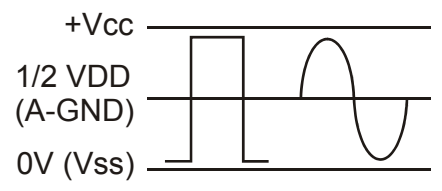
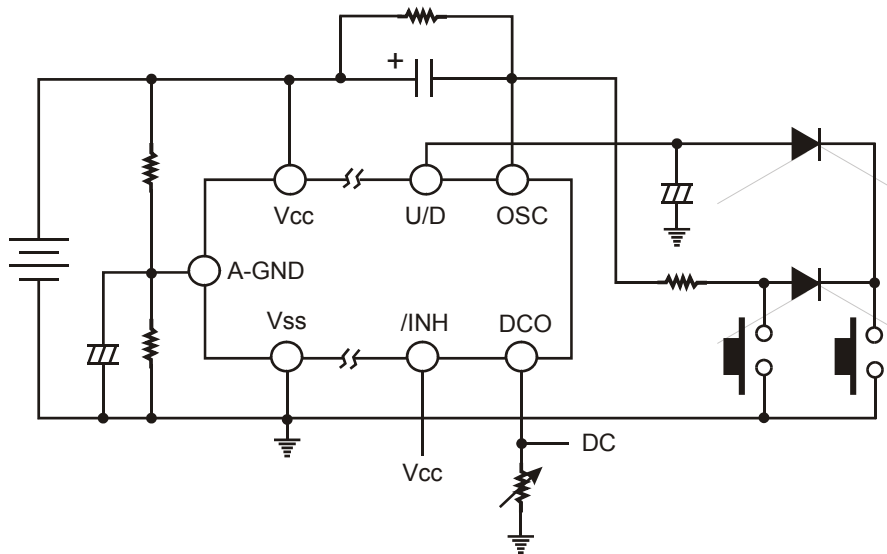



Electronic Volume Controller IC

PT2253A

INITIALIZATION WHEN POWER ON

PT2253A has the built-in auto-initializing function for during the Power ON period. It has the power supply on reset for the initialization of the chip. If the power supply rises too fast, the initialization may not be fully effected. For initialization to be fully effective, it is necessary to satisfy the following conditions:

1. The /INH Terminal must be raised simultaneously with the supply voltage.
2. Initial attenuation level is -40dB

Please refer to the following diagram.

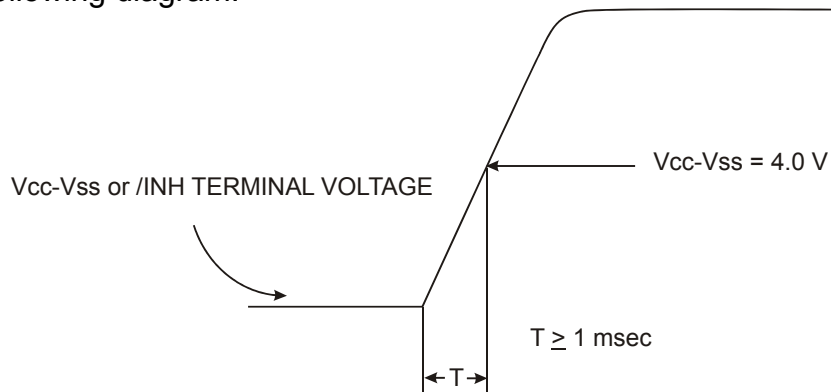

Note: If Vcc-Vss drops below 4.0V, the auto-initializing function is actuated.

BACK UP WHEN POWER OFF

When /INH Pin is set at “L” Level, all input and output pins are disabled and the current consumption is reduced to the minimum. Under this condition, the backup by means of a capacitor becomes possible. An example of this application when a backup capacitor is used is shown below.

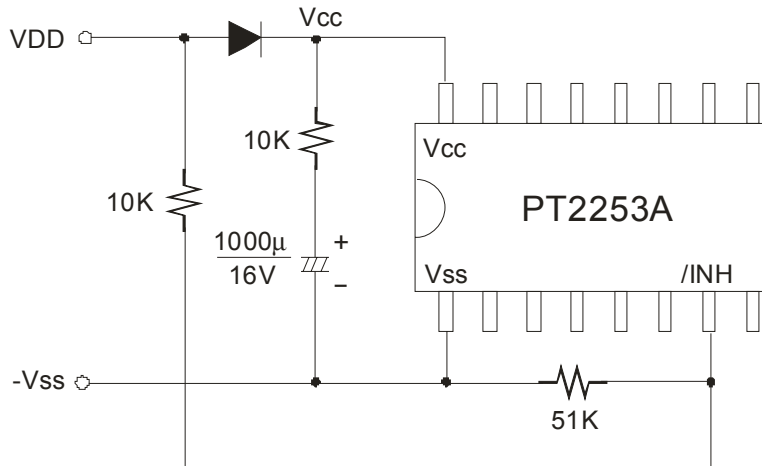

If Vcc-Vss drops below 4V, the backup becomes impossible.



Electronic Volume Controller IC

PT2253A

ABSOLUTE MAXIMUM RATINGS

Parameter	Symbol	Ratings	Unit
Operating temperature	Topr	-45 ~ +85	°C
Storage temperature	Tstg	-65 ~ +150	°C

DC ELECTRICAL CHARACTERISTICS

(Unless otherwise specified, Vcc=12V, Vss=0V and Ta=25°C)

Parameter	Symbol	Conditions	Min.	Typ.	Max.	Unit
Operating supply voltage	Vcc		6	-	12	V
Operating supply current	Icc		-	1	3	mA
Stand-by-current	ISB	Vcc=12V /INH=0V OSC=12V	-	-	10	µA
Input voltage	"H" Level VIH		0.8 x Vcc	-	Vcc + 0.3	V
(/INH, U/D)	"L" Level VIL		Vss - 0.3	-	0.2 x Vcc	
Attenuator 1 (10dB/step) resistor	RATT-1	Attenuation level is set to 0dB	25	50	70	KΩ
Attenuator 2 (2dB/step) resistor	RATT-2	Attenuation level is set to 0dB	10	20	28	KΩ
Max. input amplitude	Vin	Bias Vcc/2=6V Fin=1KHz ATT=0dB	-	-	4.0	Vrms
Operating oscillation frequency	fosc		5	-	10	KHz
DCO output current	IDCO	1 step	70	100	140	µA



Electronic Volume Controller IC

PT2253A

ELECTRICAL CHARACTERISTICS

(Unless otherwise specified, Vcc=6V, Vss=-6V, GND=0V)

IN1 ~ OUT 1

Parameter	Symbol	Condition	Max.	Unit
Signal to noise ratio	S/N	ATT=0dB Fin=1KHz Vin=1.0Vrms	97	dB
Frequency response	Fr	ATT=-10dB Fin=1KHz Vin=1.0Vp-p	657	KHz
Noise floor	NF	Vin=0V, ATT=0dB	0.015	mV
Total harmonic distortion	THD	ATT=-10dB Fin=1KHz Vin=1.0Vrms	0.010	%

IN2 ~ OUT2

Parameter	Symbol	Condition	Max.	Unit
Signal to noise ratio	S/N	ATT = 0dB Fin=1KHz Vin=1.0Vrms	95	dB
Frequency response	Fr	ATT=-2dB Fin=1KHz Vin=1.0Vp-p	1820	KHz
Noise floor	NF	Vin=0V ATT=0dB	0.022	mV
Total harmonic distortion	THD	ATT=-2dB Fin=1KHz Vin=1.0Vrms	0.009	%



APPLICATION CIRCUIT 1

DUAL POWER SUPPLY (L-CHANNEL ONLY)

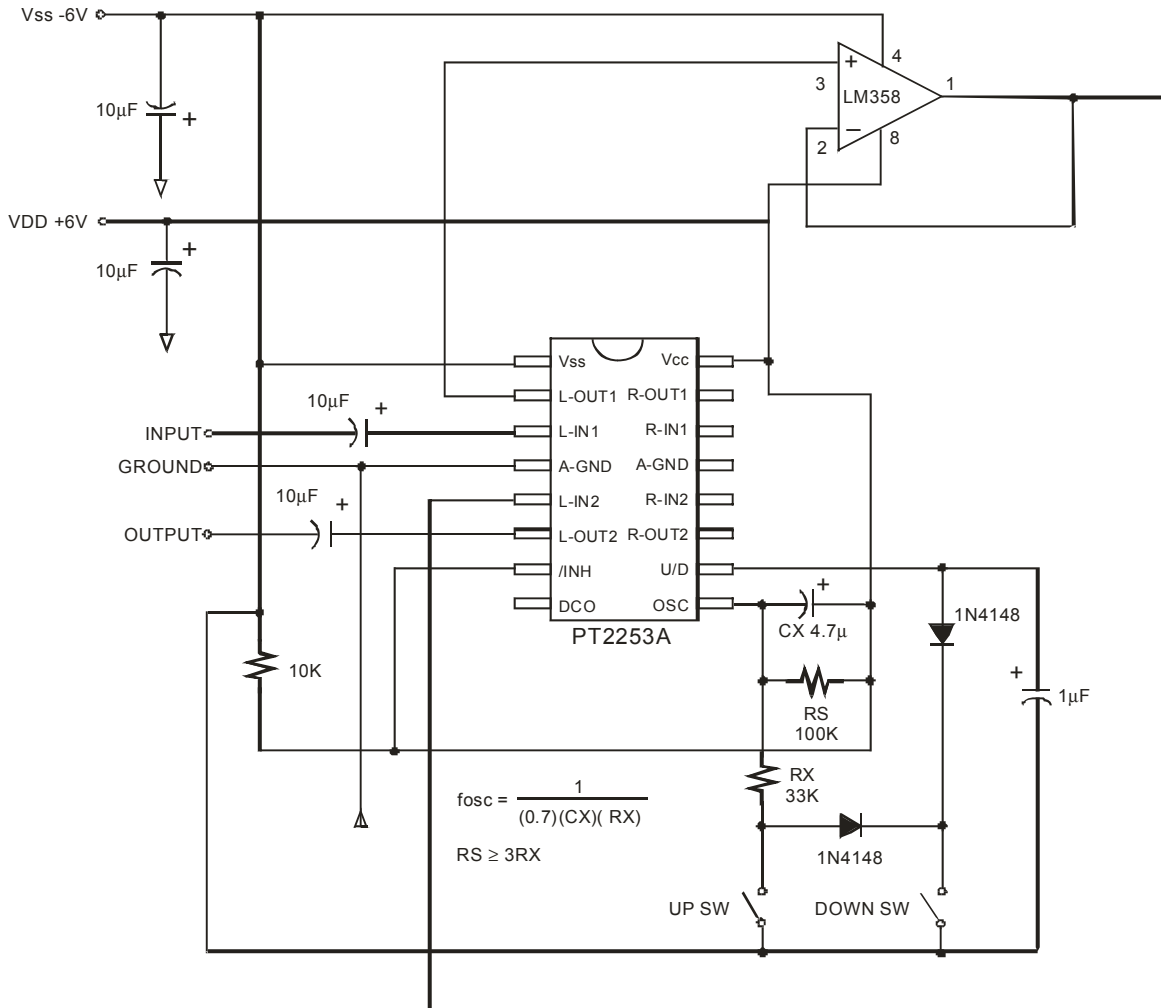



APPLICATION CIRCUIT 2

DUAL POWER SUPPLY (L-CHANNEL ONLY)

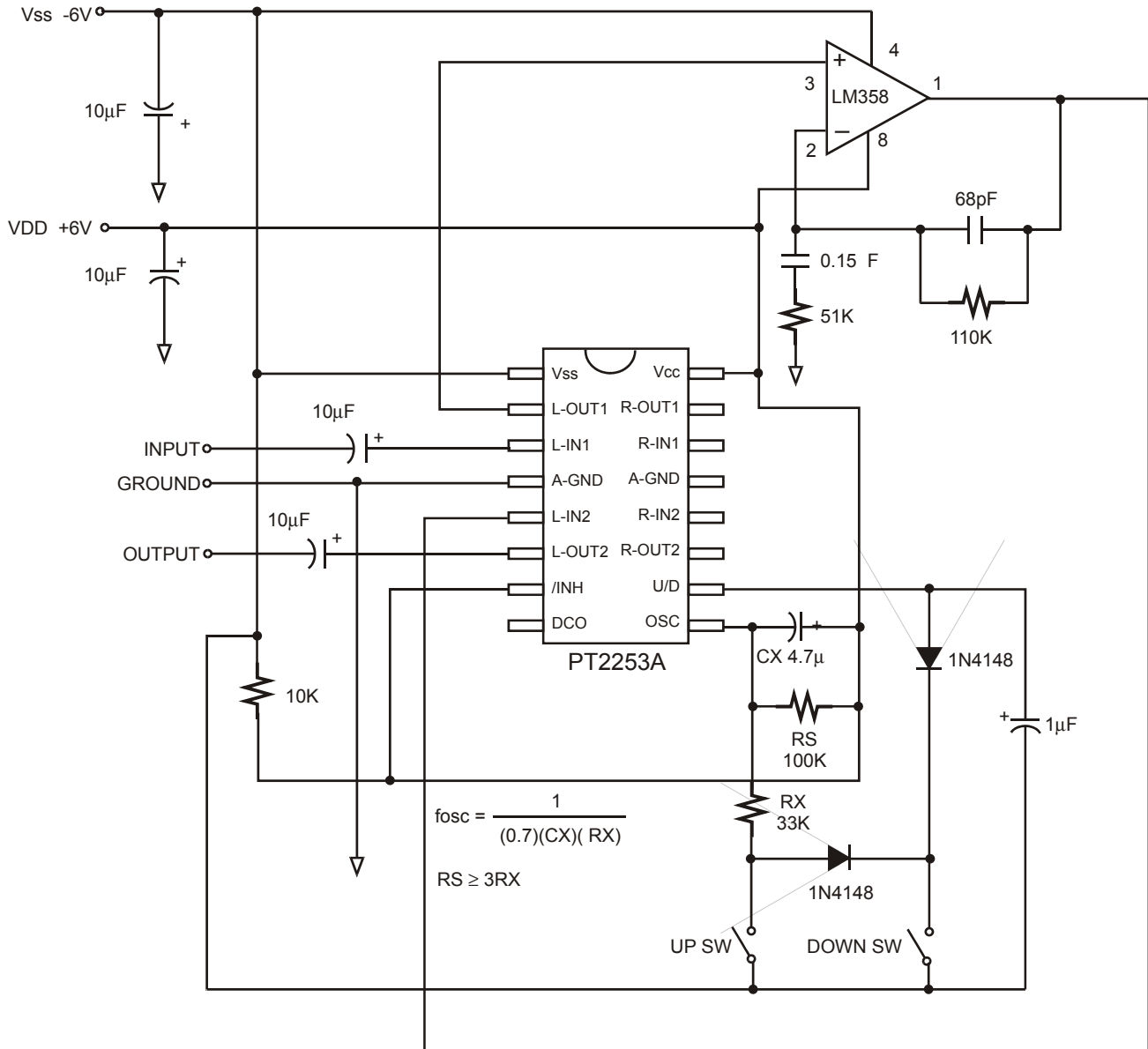

Note:

Since the buffer amp between Att-1 and Att-2 is already 10dB voltage gain, higher input level may cause OP amp's output clipping. To avoid unwanted distortion, the input signal level applied at IN-1 should not be over 1Vrms.



APPLICATION CIRCUIT 4

SINGLE POWER SUPPLY

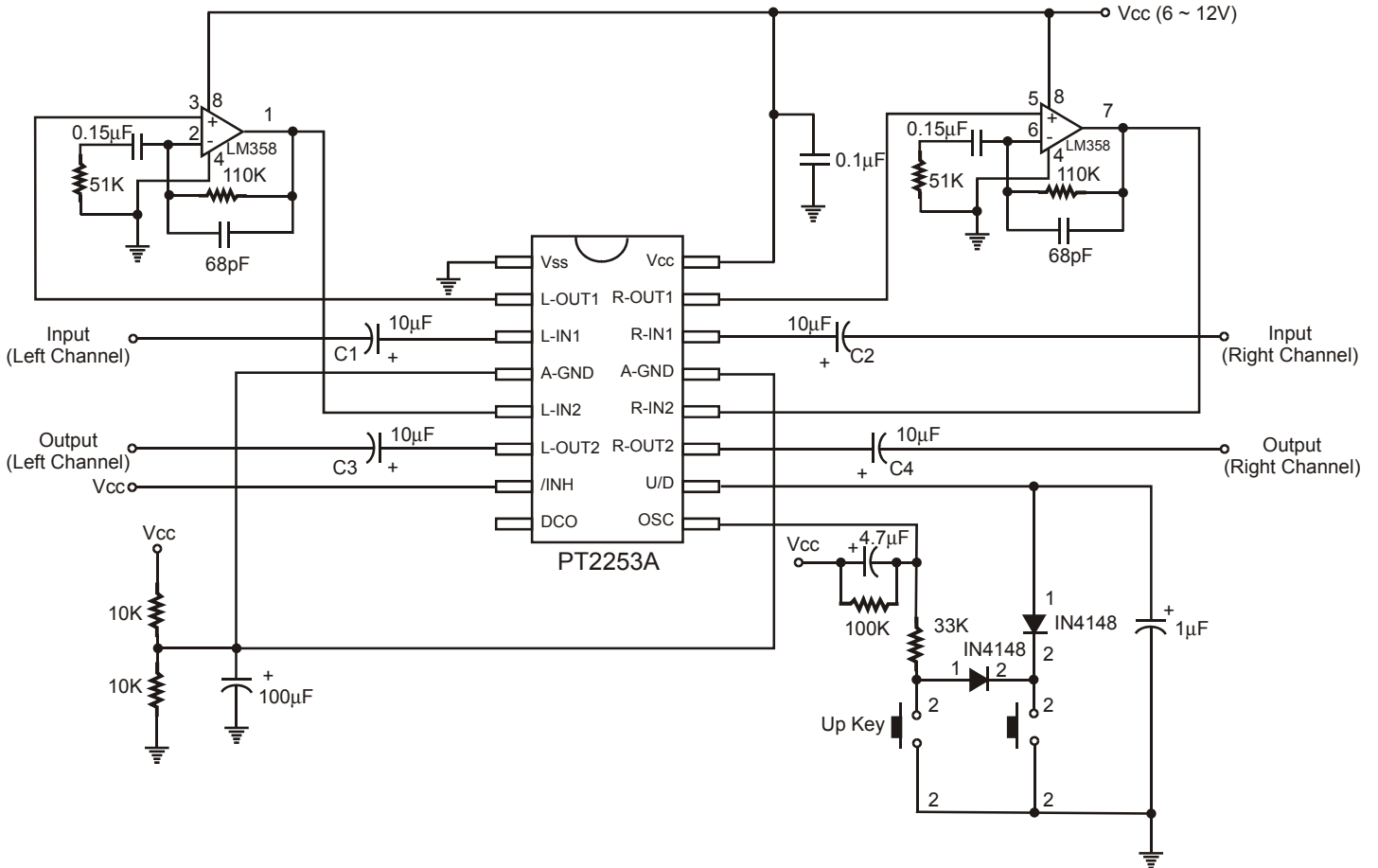

Note:

Since the buffer amp between Att-1 and Att-2 is already 10dB voltage gain, higher input level may cause OP amp's output clipping. To avoid unwanted distortion, the input signal level applied at IN-1 should not be over 1Vrms.



ORDER INFORMATION

Valid Part Number	Package Type	Top Code
PT2253A	16 Pins, DIP, 300mil	PT2253A
PT2253A-S	16 Pins, SOP, 300mil	PT2253A-S



Electronic Volume Controller IC

PT2253A

PACKAGE INFORMATION

16 PINS, DIP, 300MIL

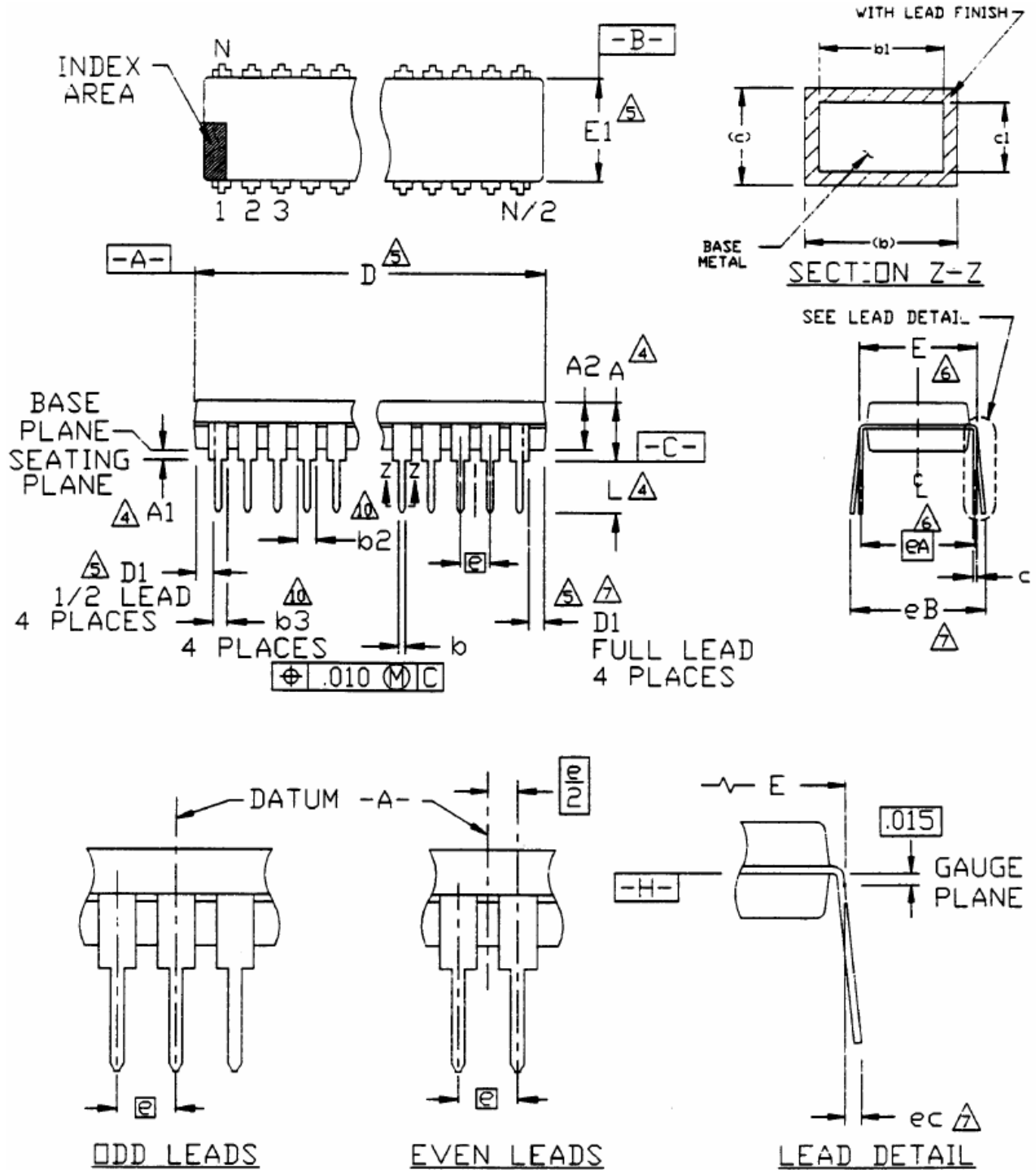



Electronic Volume Controller IC

PT2253A

Symbol	Min.	Nom.	Max.
A	-	-	0.210
A1	0.015	-	-
A2	0.115	0.130	0.195
b	0.014	0.018	0.022
b1	0.014	0.018	0.020
b2	0.045	0.060	0.070
b3	0.030	0.039	0.045
c	0.008	0.010	0.014
c1	0.008	0.010	0.011
D	0.780	0.790	0.800
D1	0.005	-	-
E	0.300	0.310	0.325
E1	0.240	0.250	0.280
e		0.100 bsc	
eA		0.300 bsc	
eB	-	-	0.430
eC	0.000	-	0.060
L	0.115	0.130	0.150

Notes:

1. Controlling Dimension: INCHES.
2. Dimensioning and tolerancing per ANSI Y14.5M-1982.
3. Dimensions A, A1 and L are measured with the package seated in JEDEC Seating Plane Gauge GS-3.
4. D, D1 and E1 dimensions do not include mold flash or protrusions. Mold flash or protrusions shall not exceed 0.010 inch.
5. E and eA measured with the leads constrained to be perpendicular to datum -C-.
6. eB and eA are measured at the lead tips with the leads unconstrained.
7. N is the maximum number of terminal positions (N=16).
8. Pointed or rounded lead tips are preferred to ease insertion.
9. b2 and b3 maximum dimensions do not include dambar protrusions. Dambar protrusions shall not exceed 0.010 (0.25mm).
10. Variation AB is a full lead package.
11. Distance between leads including dambar protrusions to be 0.005 in minimum.
12. Datum plane -H- coincident with the bottom of lead where lead exits body.
13. Refer to JEDEC MS-001 Variation AB.

JEDEC is the registered trademark of JEDEC SOLID STATE TECHNOLOGY ASSOCIATION.



Electronic Volume Controller IC

PT2253A

16 PINS, SOP, 300MIL

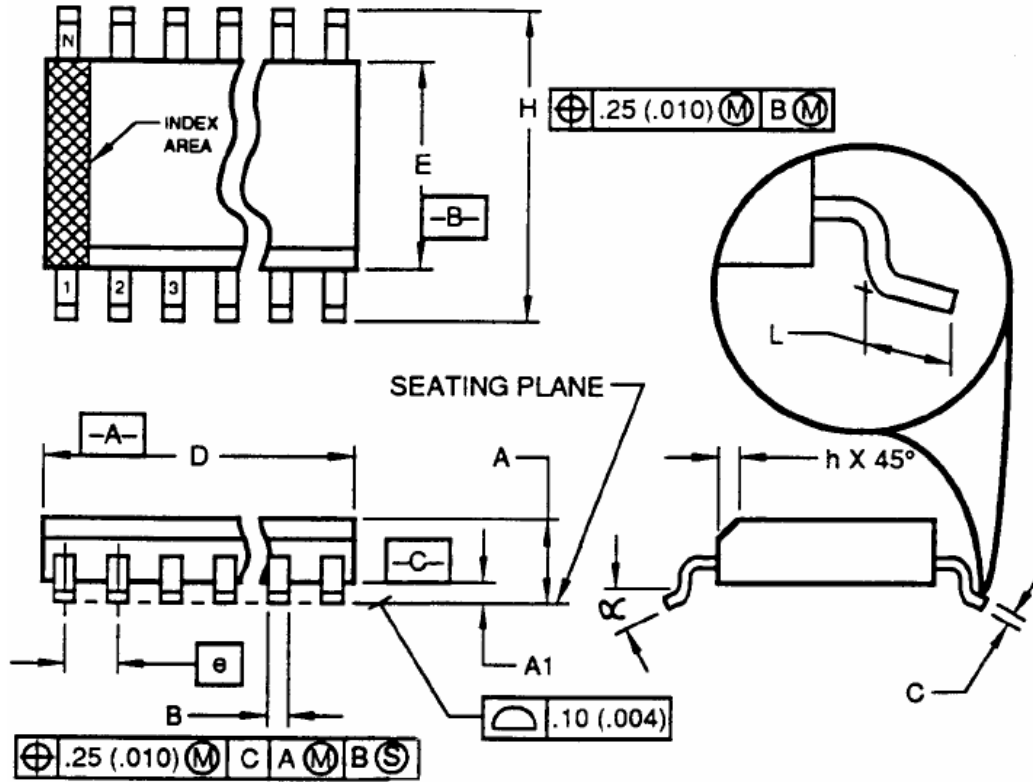



Electronic Volume Controller IC

PT2253A

Notes:

1. Controlling Dimension: MILLIMETER
2. Dimensioning and tolerancing per ANSI Y14.5M-1982.
3. Dimension D does not include mold flash, protrusions or gate burrs. Mold flash, protrusions and gate burrs shall not exceed 0.15mm (0.006 in) per side.
4. Dimension E does not include interlead flash or protrusions. Interlead flash and protrusions shall not exceed 0.25 mm (0.010 in.) per side.
5. The chamfer on the body is optional. If it is not present, a visual index feature must be located within the crosshatched area.
6. L is the length of the terminal for soldering to a substrate.
7. N is the number of terminal positions (N=16).
8. The lead width B, as measured 0.36 mm (0.014in) or greater above the seating plane, shall not exceed a maximum value of 0.61mm (0.024in.)
9. Refer to JEDEC MS-013 Variation AA.

JEDEC is the registered trademark of JEDEC SOLID STATE TECHNOLOGY ASSOCIATION.