

DESCRIPTION

The PT2037 is a multiple functions audio signal processor, very low distortion and low noise are obtained by the advanced CMOS fabricate technology. All of characteristics and functions are designed for the customer who needs high performance and better hearing experience. This device provides a lot of new features like soft-mute and zero-crossing mute to minimize the noises during the audio sources are switching. Further more, the device equipped differential audio inputs to improve the Common Mode Reject Ratio and it is very helpful to canceling ground loop hum noises in the car and audio dock system.

APPLICATIONS

- Car audio
- Audio dock system
- Mini compo system

FEATURES

- Input multiplexer
 - 4 Stereo input
 - 1 Mono input
 - 1 Differential input
 - Selectable input gain for optimal adaptation to different sources
- Multiple MUTE function
 - Software controlled: Direct Mute, Zero-Crossing Mute and Soft Mute
 - Hardware controlled: Soft Mute
- Fully programmable loudness function
- Volume control in 1dB steps including gain up to 16dB
- 3 band (Bass, Middle and Treble) tone control
- Four independent speaker attenuators control in 1dB steps for balance and fader facilities
- Programmable threshold for pause and zero cross mute detector
- All functions programmable via serial I²C bus

BLOCK DIAGRAM

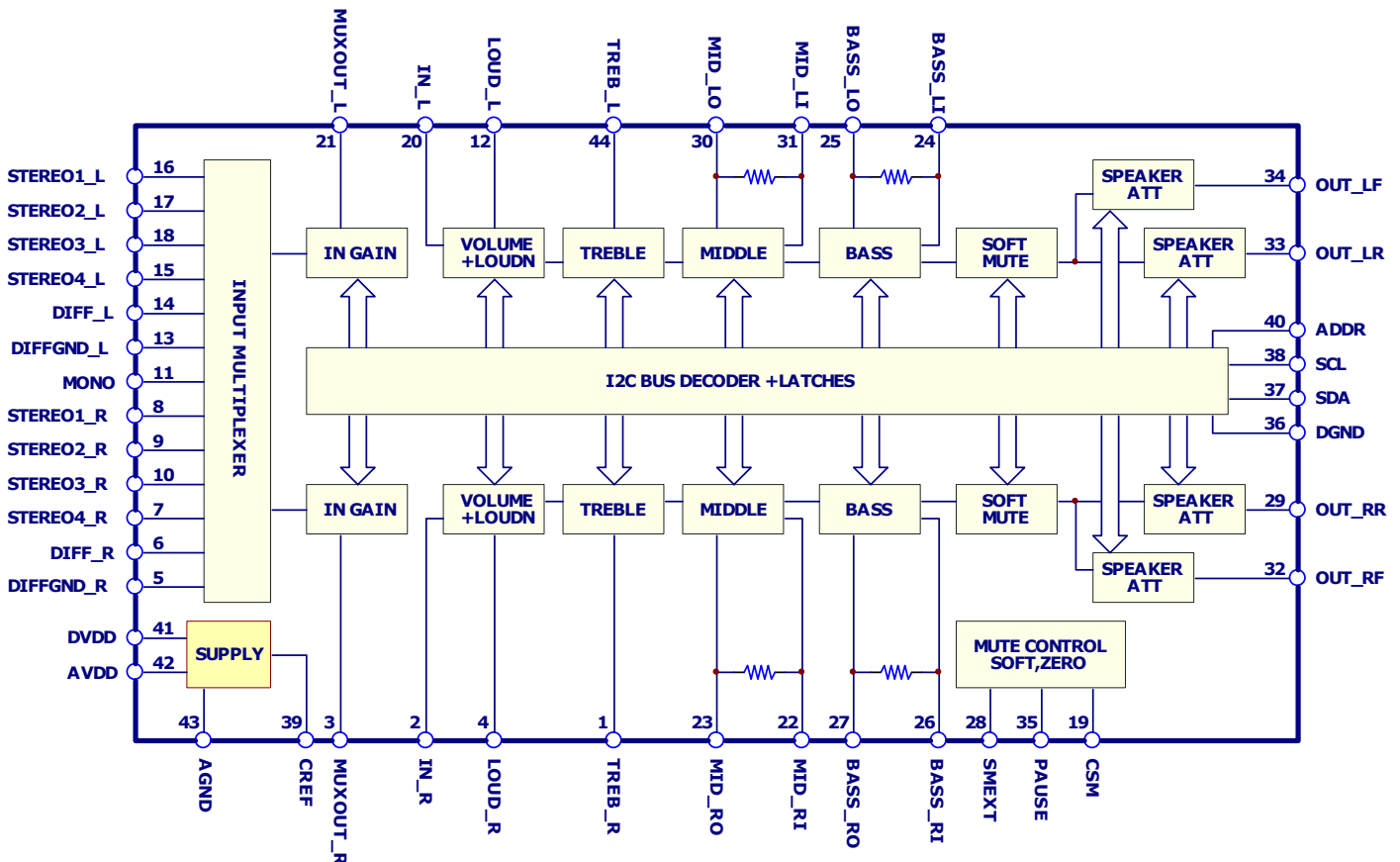

APPLICATION CIRCUIT

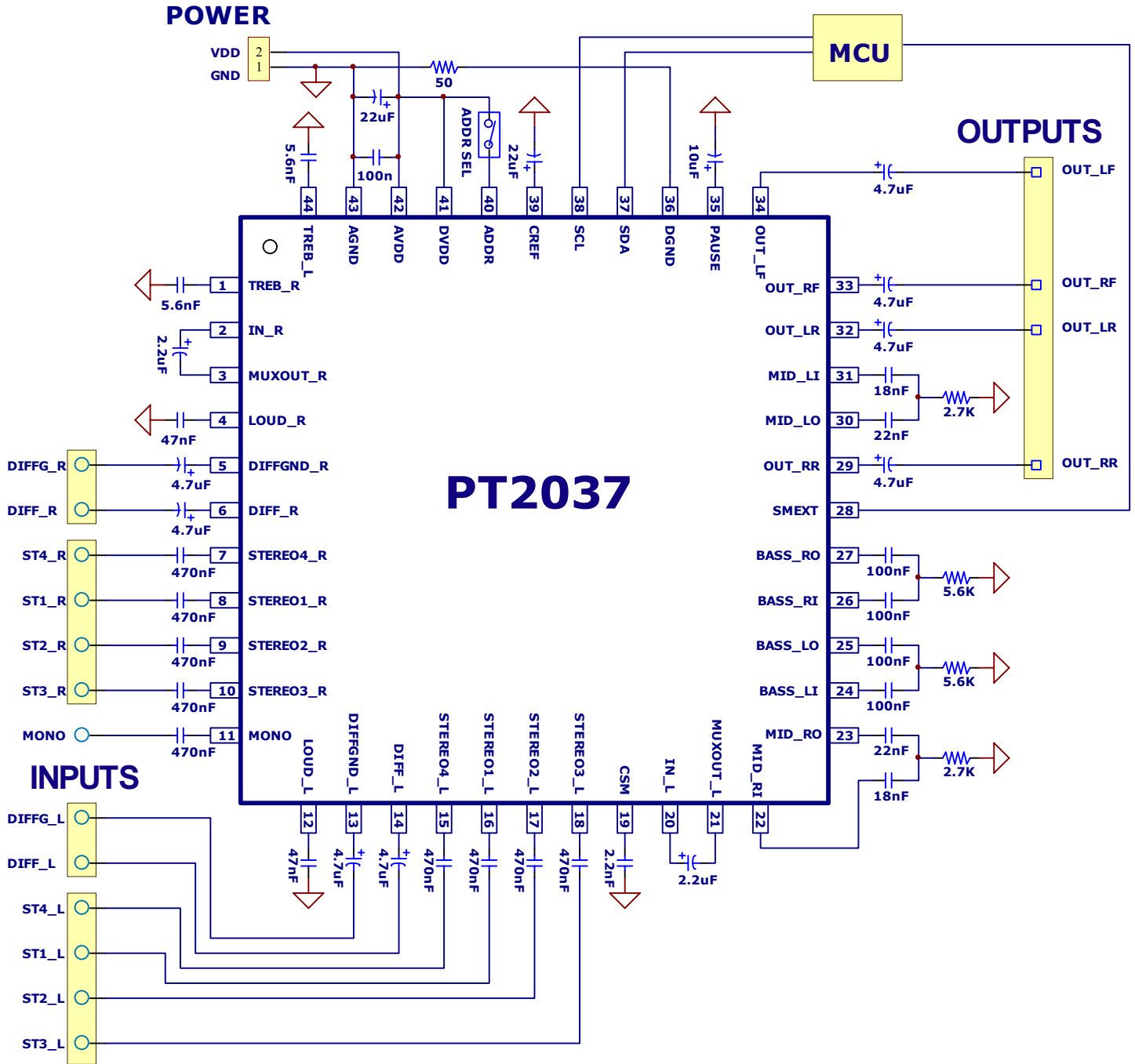

Notes:

1. AGND and DGND trace on the PCB layout must be separated, tight separated GND path together on the bypassing capacitor negative terminal. A 50Ω resistor on the DGND path could minimize the I²C noises to interference audio outputs.
2. Refer the differential input section description to achieve correspond wiring instruction.

ORDER INFORMATION

Valid Part Number	Package Type	Top Code
PT2037-LQ	44 Pins, LQFP	PT2037-LQ

PIN CONFIGURATION

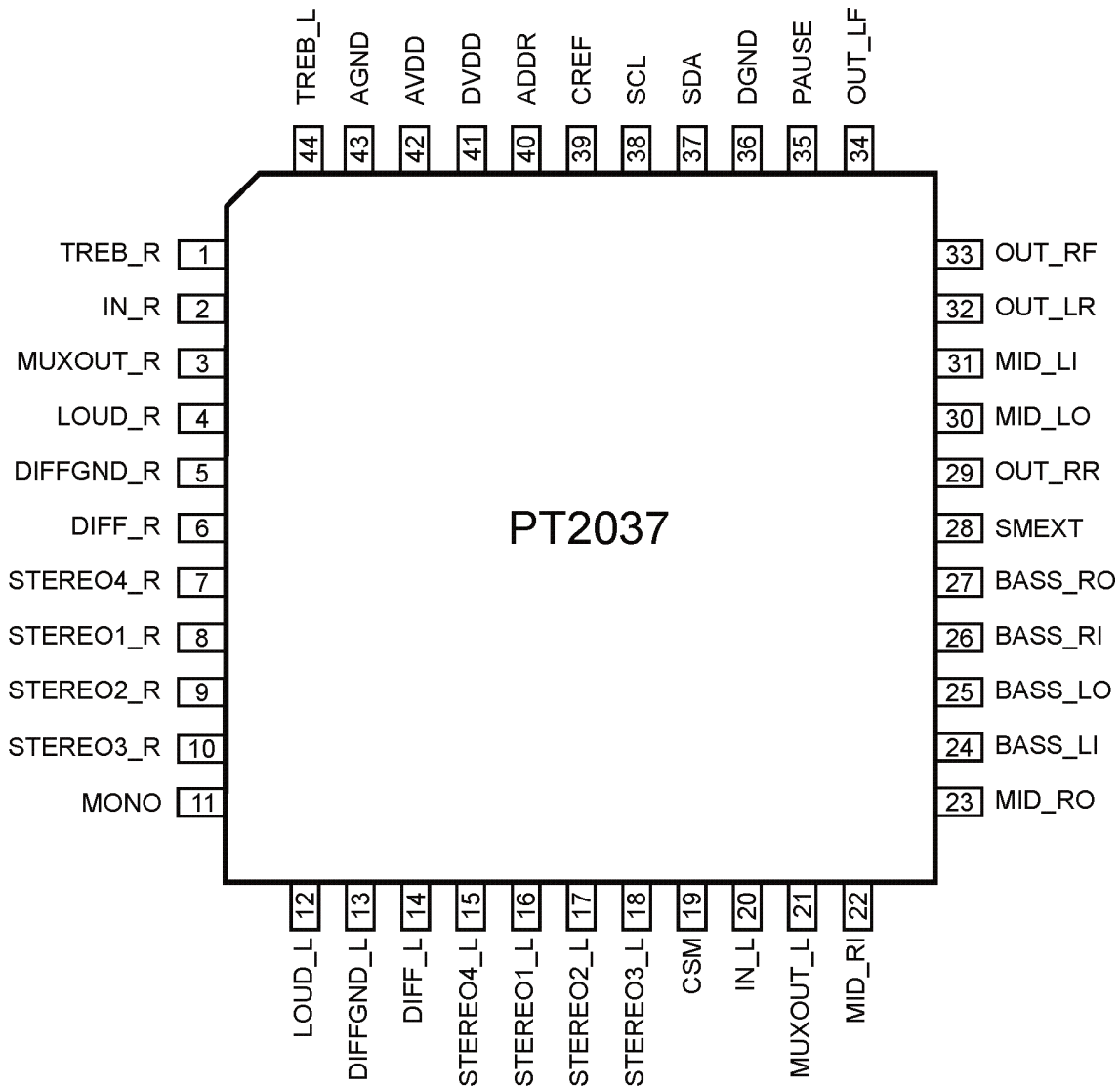

PIN DESCRIPTION

Pin Name	I/O	Description	Pin No.
TREB_R	I	External Cap for the right channel treble filter	1
IN_R	I	Volume input of the right channel	2
MUXOUT_R	O	Sources selection multiplexer output of the right channel	3
LOUD_R	I	External Cap for the right channel loudness filter	4
DIFFGND_R	I	Negative input of the differential amplifier, right channel	5
DIFF_R	I	Positive input of the differential amplifier, right channel	6
STEREO4_R	I	Single-ended input No.4 of the right channel	7
STEREO1_R	I	Single-ended input No.1 of the right channel	8
STEREO2_R	I	Single-ended input No.2 of the right channel	9
STEREO3_R	I	Single-ended input No.3 of the right channel	10
MONO	I	Mono audio input	11
LOUD_L	I	External Cap for the left channel loudness filter	12
DIFFGND_L	I	Negative input of the differential amplifier, left channel	13
DIFF_L	I	Positive input of the differential amplifier, left channel	14
STEREO4_L	I	Single-ended input No.4 of the left channel	15
STEREO1_L	I	Single-ended input No.1 of the left channel	16
STEREO2_L	I	Single-ended input No.2 of the left channel	17
STEREO3_L	I	Single-ended input No.3 of the left channel	18
CSM	I	Determinate soft mute time constant, connect a cap to GND	19
IN_L	I	Volume input of the left channel	20
MUXOUT_LR	O	Sources selection multiplexer output of the left channel	21
MID_RI	I	Right channel mid filter input	22
MID_RO	O	Right channel mid filter output	23
BASS_LI	I	Left channel bass filter input	24
BASS_LO	O	Left channel bass filter output	25
BASS_RI	I	Right channel bass filter input	26
BASS_RO	O	Right channel bass filter output	27
SMEXT	I	Soft mute hardware control pin, internal pull up to half of AVDD, pull down to GND active soft mute function, open or pull up to AVDD for normal operation.	28
OUT_RR	O	Right channel rear output	29
MID_LO	O	Left channel mid filter output	30



Pin Name	I/O	Description	Pin No.
MID_LI	I	Left channel mid filter input	31
OUT_LR	O	Left channel rear output	32
OUT_RF	O	Right channel front output	33
OUT_LF	O	Left channel front output	34
PAUSE	O	Pause detector output	35
DGND	-	Digital ground	36
SDA	I	I ² C data input/output	37
SCL	I	I ² C clock input	38
CREF	I	Internal reference bypass, connect a cap to AGND	39
ADDR	I	I ² C chip address selection, keep open=88H, pull up to DVDD =8AH.	40
DVDD	-	Digital power supply	41
AVDD	-	Analog power supply	42
AGND	-	Analog ground	43
TREB_L	I	External cap for left channel treble filter	44

IMPORTANT NOTICE

Princeton Technology Corporation (PTC) reserves the right to make corrections, modifications, enhancements, improvements, and other changes to its products and to discontinue any product without notice at any time.

PTC cannot assume responsibility for use of any circuitry other than circuitry entirely embodied in a PTC product. No circuit patent licenses are implied.

Princeton Technology Corp.
2F, 233-1, Baociao Road,
Sindian, Taipei 23145, Taiwan
Tel: 886-2-66296288
Fax: 886-2-29174598
<http://www.princeton.com.tw>