

## DESCRIPTION

The PT2033 is an audio processor designed for versatile application, it includes 3 stereo input selector with internal gain, master volume control with low frequency loudness compensation, individual channel output volume adjust and tone control.

If a system wants subwoofer signal output, traditional solution needs a lot of discrete components and OPAMP to consist of low pass filter; in the PT2033, just needs 2 capacitors only. The PT2033 combine the low pass filter inside the audio processor and user may determine low pass corner frequency by the capacitance. Broader supply range emphasis support to every application.

## APPLICATIONS

- TV
- Mini compo
- Multimedia speaker
- Audio docking system

## FEATURES

- CMOS technology
- Controlled by I<sup>2</sup>C interface
- 3 Stereo Inputs with gain selection.
- Input gain range, from 0dB to +11.25dB, 3.75dB per step
- 2 channels master volume: from 0 dB to -78.75dB, 1.25dB per step
- Built In channel mixer and lowpass filter for subwoofer output
- Subwoofer output volume : from 0dB to -37.5dB, 1.25dB per step
- Tone control (Bass and Treble): from -14dB to +14dB, 2dB per step
- Wide operation range(VDD from 4V to 10V)
- Low harmonic distortion (0.002%, Vo=200mVrms)
- Low noise and DC offset
- 32-pin SOP package

## BLOCK DIAGRAM

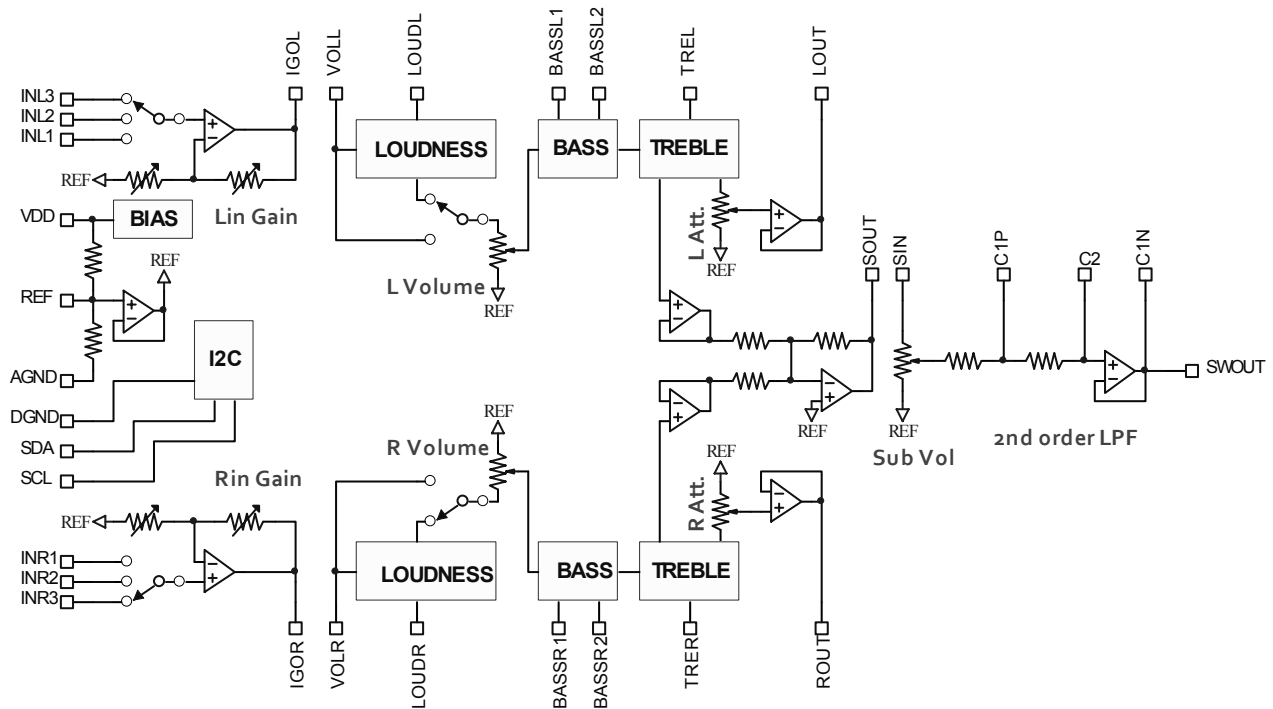

# APPLICATION CIRCUIT

## STANDARD APPLICATION CIRCUIT

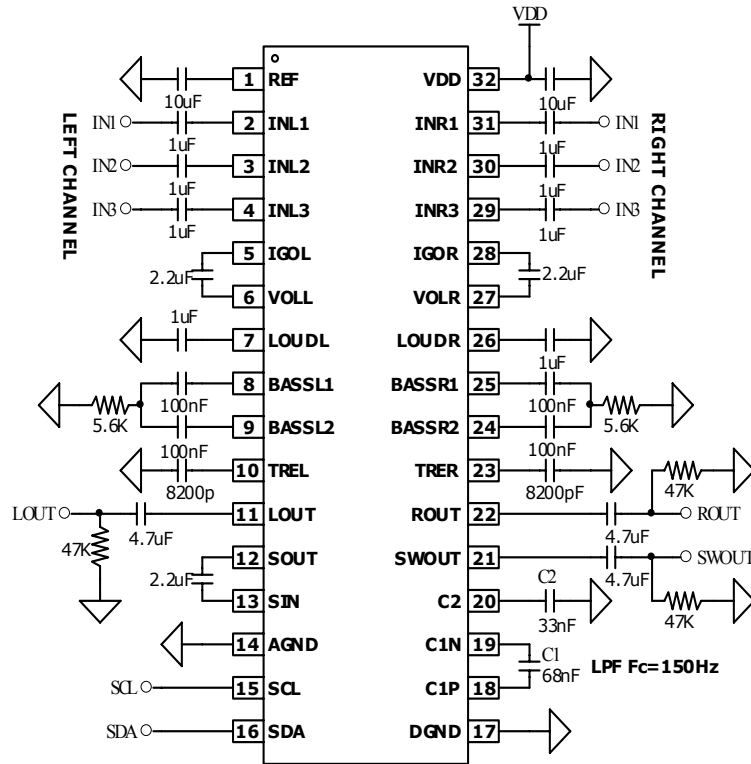

## CHANNEL SPEAKER SYSTEM (WIRING SIMPLIFIED)

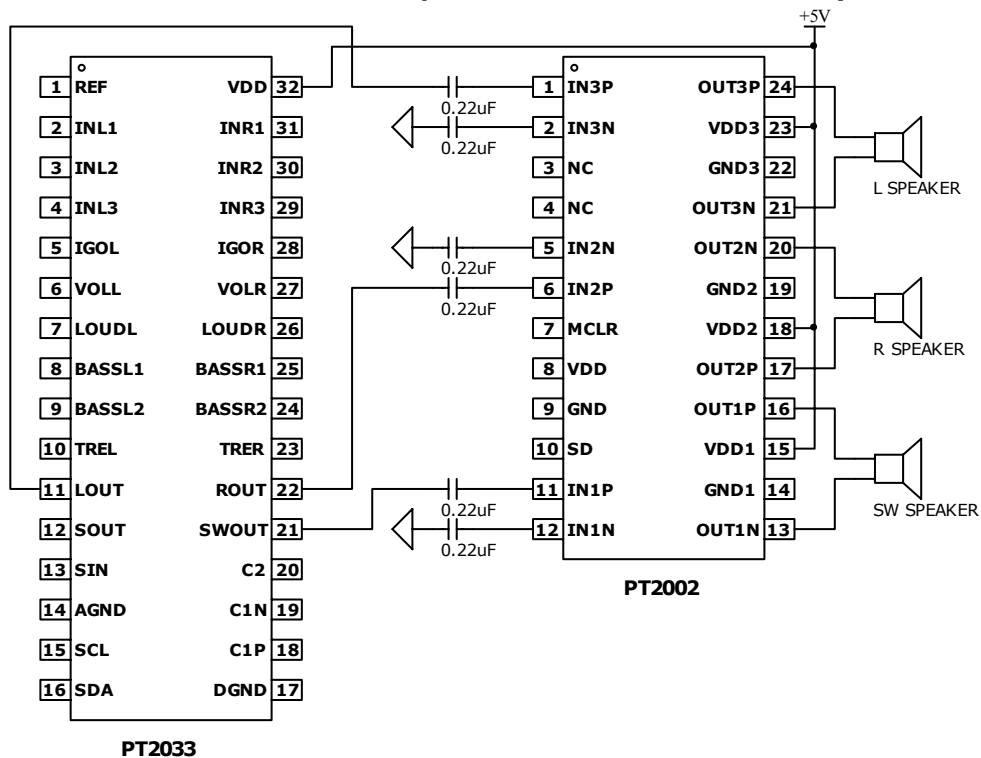

## ORDER INFORMATION

Valid Part Number	Package Type	Top Code
PT2033-S	32 Pins, SOP, 300mil	PT2033-S

## PIN CONFIGURATION

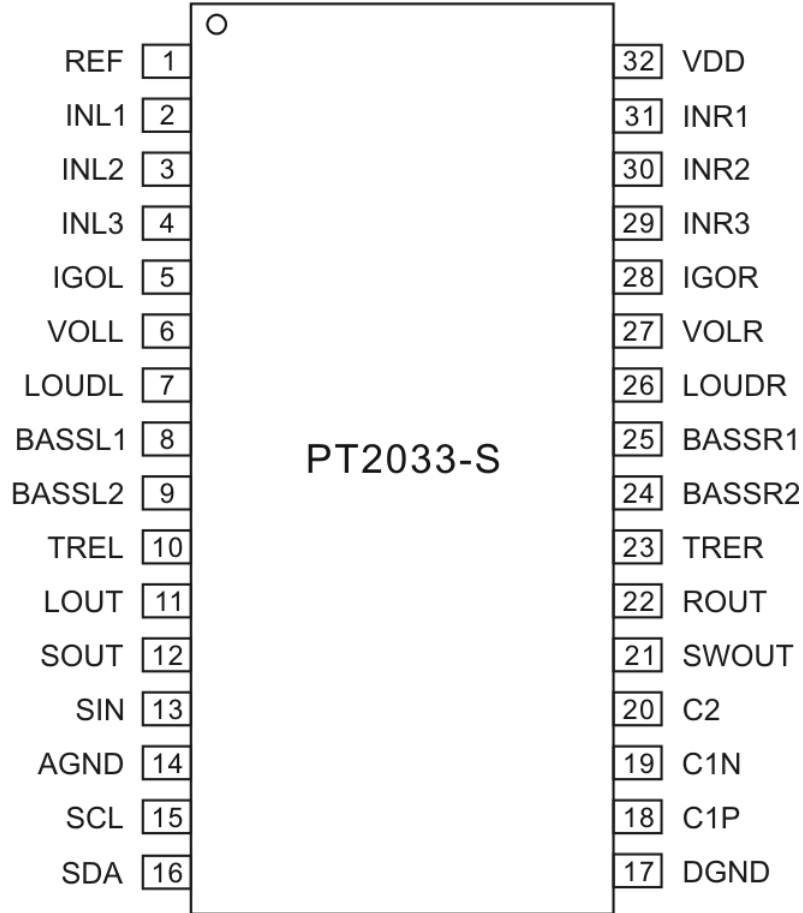

## **IMPORTANT NOTICE**

Princeton Technology Corporation (PTC) reserves the right to make corrections, modifications, enhancements, improvements, and other changes to its products and to discontinue any product without notice at any time.

PTC cannot assume responsibility for use of any circuitry other than circuitry entirely embodied in a PTC product. No circuit patent licenses are implied.

Princeton Technology Corp.  
2F, 233-1, Baociao Road,  
Sindian, Taipei 23145, Taiwan  
Tel: 886-2-66296288  
Fax: 886-2-29174598  
<http://www.princeton.com.tw>