

DESCRIPTION

The PT6587 is 1/4 duty general-purpose LCD driver that can be used for frequency display in electronic tuners under the control of a microcontroller. The PT6587 can drive an LCD with up to 208 segments directly. The PT6587 can also control up to 8 general-purpose output ports.

APPLICATION

- Electronic equipment with LCD Display

FEATURES

- Switching between 1/2 bias and 1/3 bias drive techniques under serial data control.
- Up to 208 segments for 1/4 duty drive can be displayed.
- Serial data control of switching between the segment output port and the general-purpose output port functions.
- Serial data control of frame frequency for common and segment output waveforms.
- High generality, since display data is displayed directly without decoder intervention.
- Built-in OSC circuit
- The INHB pin can force the display to the off state.

BLOCK DIAGRAM

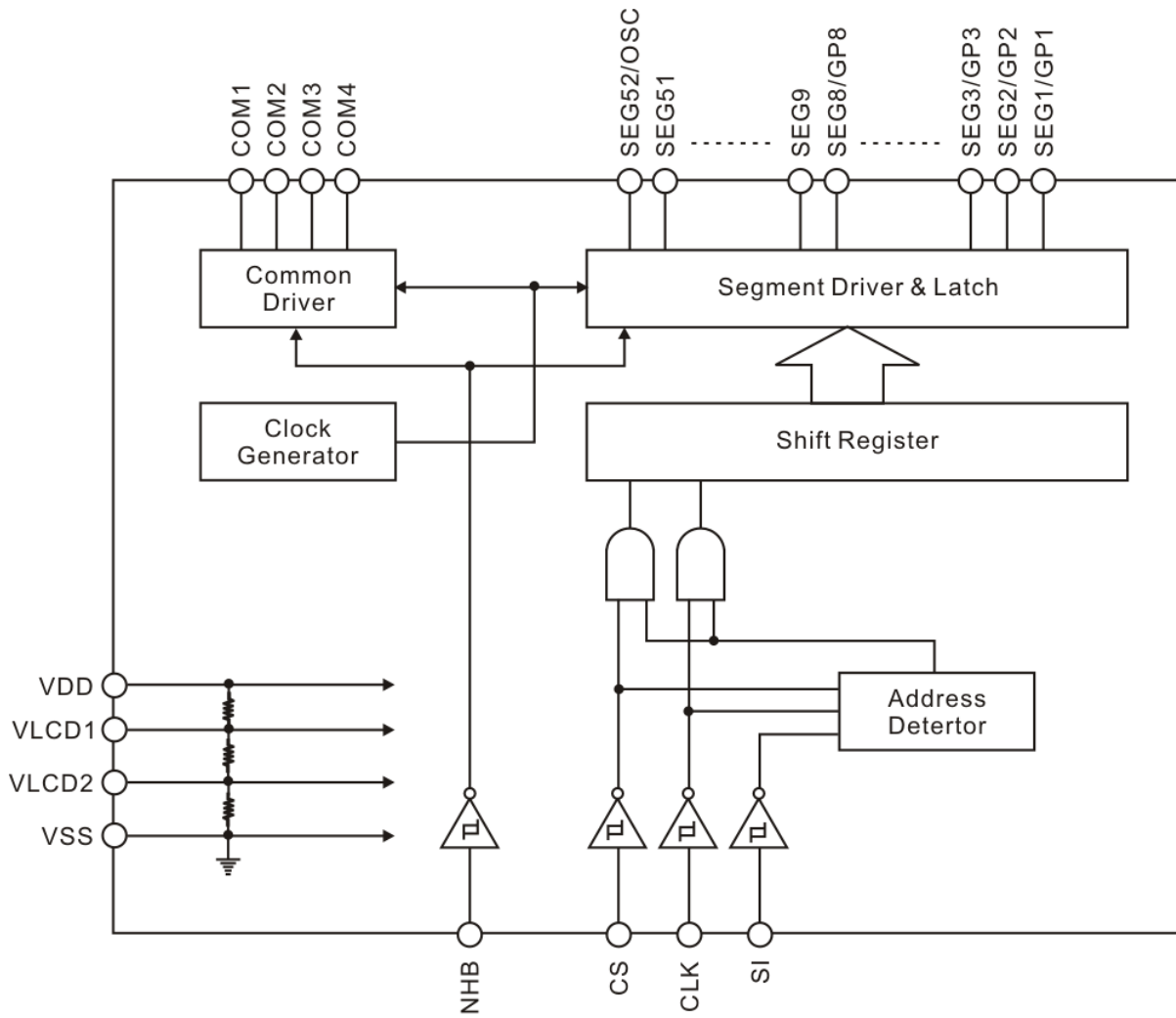



APPLICATION CIRCUIT 1

1/2 BIAS

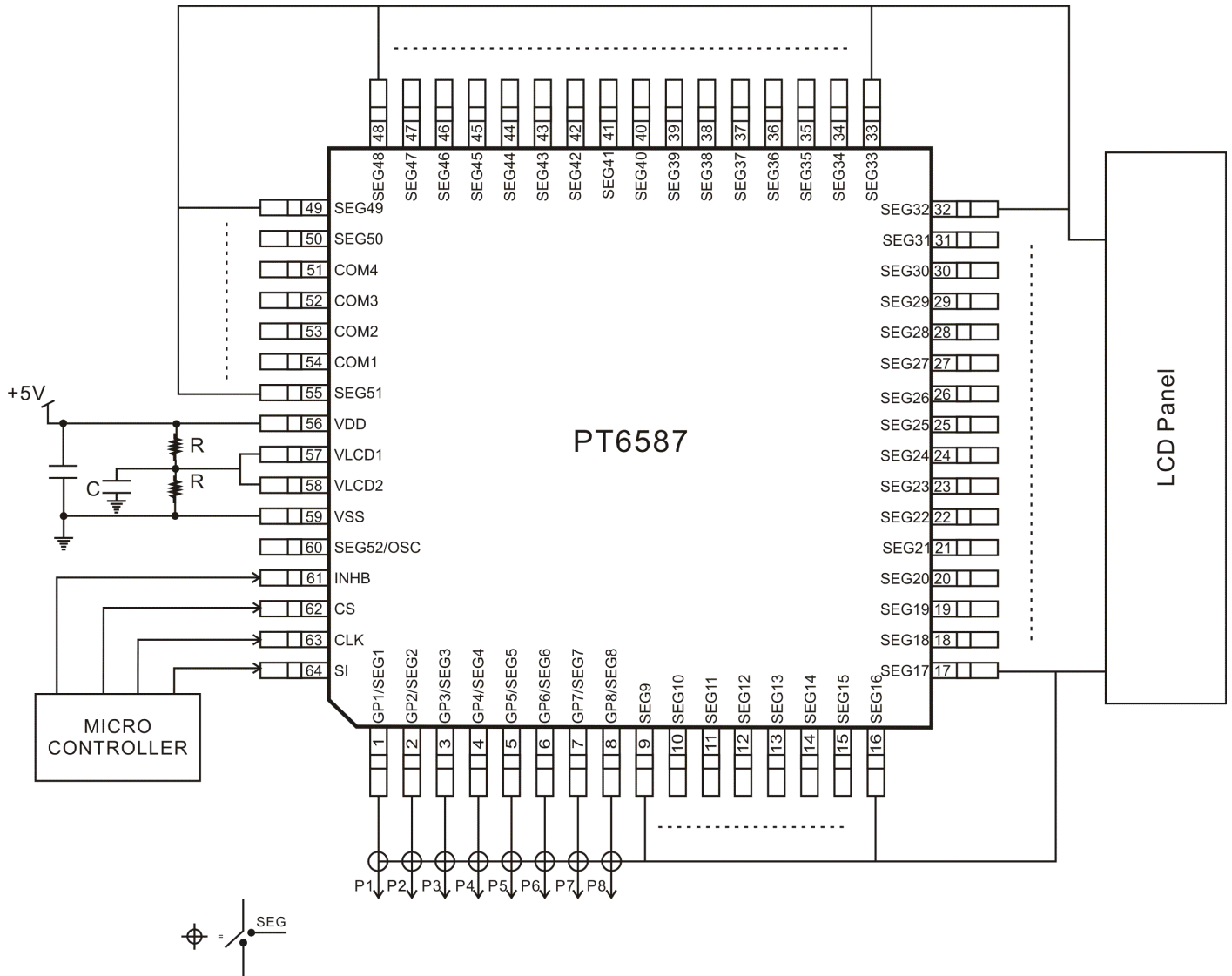

Notes:

1. $10K\Omega > R > 1K\Omega$
2. $C > 0.047\mu F$

APPLICATION CIRCUIT 2

1/3 BIAS

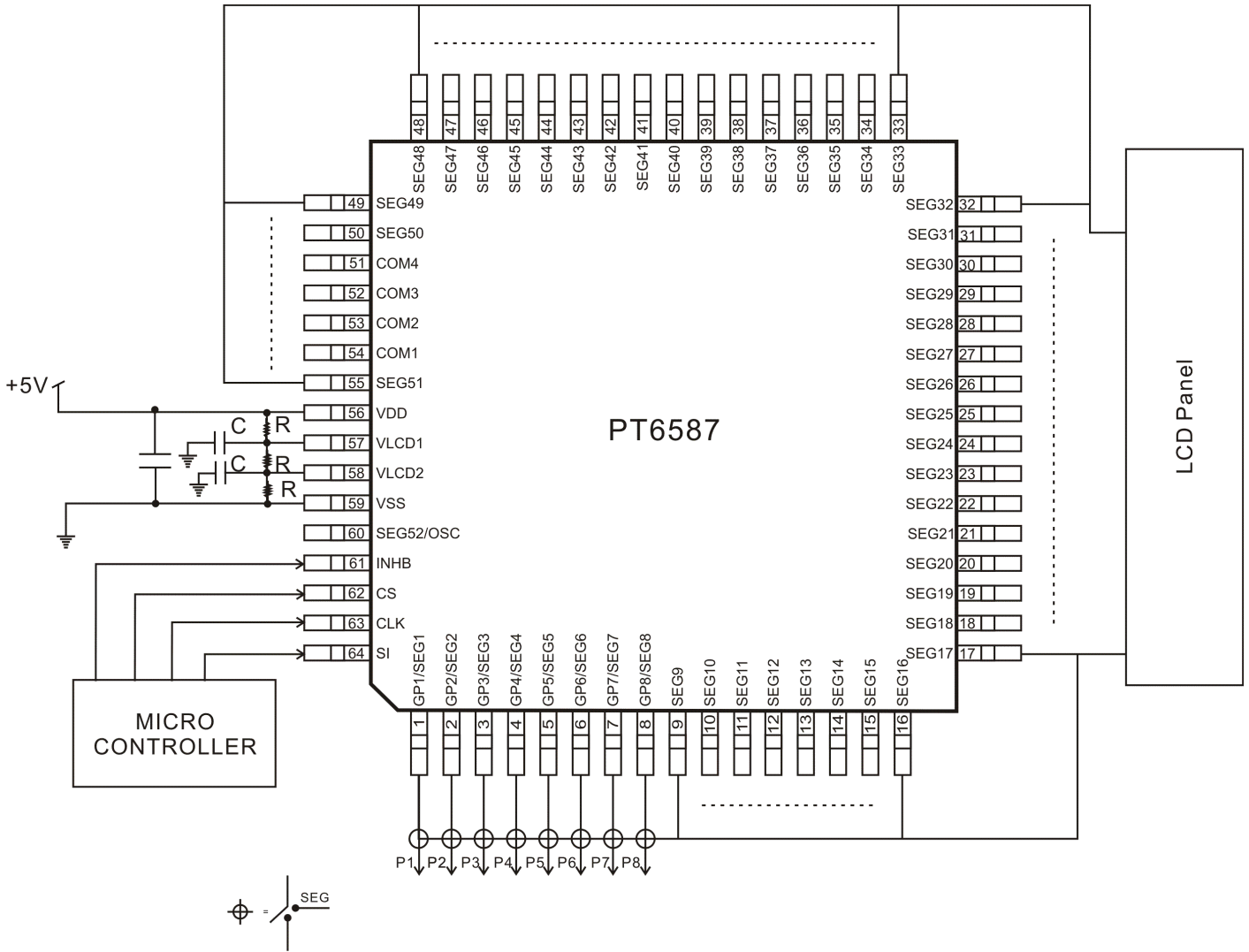

- Notes:
1. $10K\Omega > R > 1K\Omega$
 2. $C > 0.047\mu F$

PIN DESCRIPTION

Pin Name	I/O	Active	Handling when unused	Function	Pin No.
SEG1/GP1 to SEG8/GP8 SEG9 to SEG51	O	-	Open	Segment outputs for displaying the display data transferred by serial data input. The pins SEG1/GP1 to SEG8/GP8 can be used as general-purpose output ports when set up by the control data.	1 to 8 9 to 50, 55
COM1 to COM4	O	-	Open	Common driver outputs. The frame frequency is f_0 Hz.	51 to 54
VDD	-	-	-	Logic block power supply. Provide a voltage in the range 4.5 to 6.0V.	56
VLCD1	I	-	Open	LCD drive 2/3 bias voltage (middle level) supply. It is possible to supply the 2/3 V_{DD} voltage to this pin externally. This pin must be shorted to V_{LCD2} if 1/2 bias is used.	57
VLCD2	I	-	Open	LCD drive 1/3 bias voltage (middle level) supply. It is possible to supply the 1/3 V_{DD} voltage to this pin externally. This pin must be shorted to V_{LCD1} if 1/2 bias is used.	58
VSS	-	-	-	Ground pin. Connect to ground.	59
SEG52/OSC	I/O	-	VDD	Segment outputs for displaying the display data transferred by serial data input. The pin SEG52/OSC can be used external frequency input pin when set up by the control data.	60
INHB	I	L	GND	Display off control input <ul style="list-style-type: none"> • INHB=low (V_{SS})...off SEG1/GP1 to SEG8/GP8=low (V_{SS}) (These pins are forcibly set to the segment output port function and fixed at the V_{SS} level) SEG9 to SEG52=low (V_{SS}) COM1 to COM4=low (V_{SS}) • INHB=high (V_{DD})...on Note that serial data transfers can be performed when the display is forced off by this pin.	61
CS	I	H	GND	Serial data transfer inputs. These pins are connected to the control microprocessor. CS: Chip select CLK: Synchronization clock SI: Transfer data	62
CLK	I				63
SI	I	-			64

IMPORTANT NOTICE

Princeton Technology Corporation (PTC) reserves the right to make corrections, modifications, enhancements, improvements, and other changes to its products and to discontinue any product without notice at any time.

PTC cannot assume responsibility for use of any circuitry other than circuitry entirely embodied in a PTC product. No circuit patent licenses are implied.

Princeton Technology Corp.
2F, 233-1, Baociao Road,
Sindian Dist., New Taipei City 23145, Taiwan
Tel: 886-2-66296288
Fax: 886-2-29174598
<http://www.princeton.com.tw>