

NHD-320240WG-BoTML-VZ#-030

Graphic Liquid Crystal Display Module

NHD-	Newhaven Display
320240-	320 x 240 pixels
WG-	Display Type: Graphic
Bo-	Model
T-	White LED Backlight
M-	STN- Negative Blue
L-	Transmissive, 12:00 view, Wide Temperature (-20°C ~+70°C)
VZ#-	Built-in Negative Voltage
030-	110mm FFC, Touch panel, JF1, JF2 shorted
	RoHS Compliant

Newhaven Display International, Inc.

2511 Technology Drive, Suite 101

Elgin IL, 60124

Ph: 847-844-8795

Fax: 847-844-8796

www.newhavendisplay.com

nhtech@newhavendisplay.com

nhsales@newhavendisplay.com

Document Revision History

Revision	Date	Description	Changed by
0	6/7/2007	Initial Release	-
1	3/15/2010	User guide reformat	MC
2	9/2/2010	Mechanical drawing update	MP
3	2/20/2013	Mechanical drawing updated, TP characteristics added	AK

Functions and Features

- 320 x 240 pixels
- Built-in RA8835 Controller
- +5.0V power supply
- 4-Wire Resistive Touch Panel
- RoHS Compliant

Mechanical Drawing

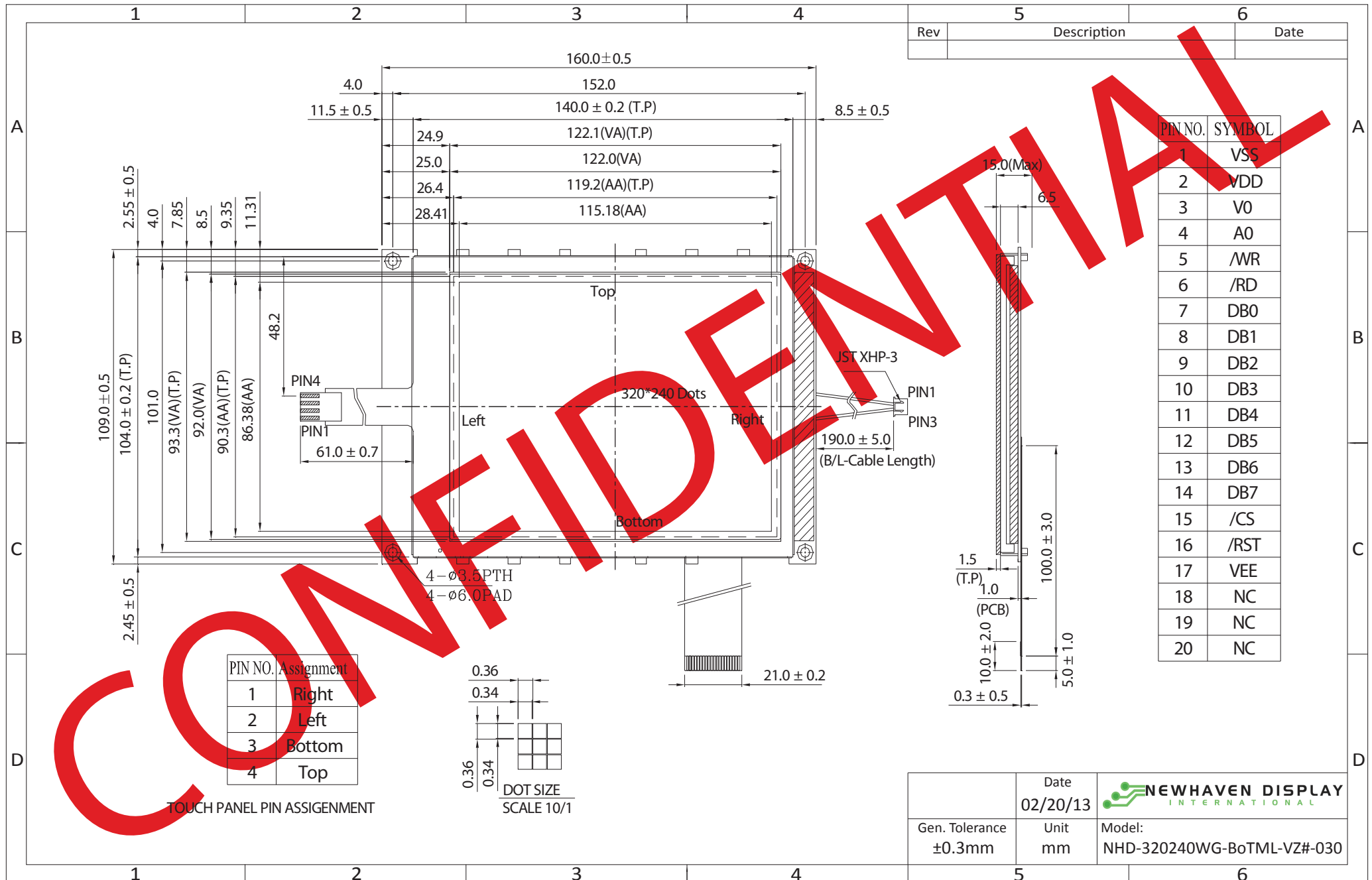

The drawing contained herein is the exclusive property of Newhaven Display International, Inc. and shall not be copied, reproduced, and/or disclosed in any format without permission.

Pin Description and Wiring Diagram

Pin No.	Symbol	External Connection	Function Description
1	VSS	Power Supply	Ground
2	VDD	Power Supply	Power supply for logic (+5.0V)
3	VO	Adj Power Supply	Power supply for contrast (approx. -19.0V)
4	A0	MPU	Register select signal. A0=0: Command, A0=1: Data
5	/WR R/W	MPU	8080 mode (default): Active LOW write strobe 6800 mode: Read/Write select signal, R/W=1: Read R/W: =0: Write
6	/RD E	MPU	8080 mode (default): Active LOW read strobe 6800 mode: Operation enable signal. Falling edge triggered.
7-14	DB0-DB7	MPU	Bi-directional three-state data bus lines
15	/CS	MPU	Active LOW chip select
16	/RST	MPU	Active LOW reset signal
17	VEE	Power Supply	Negative voltage output (-25V)
18	NC	-	No Connect
19	NC	-	No Connect
20	NC	-	No Connect

Note: To change from 8080 mode to 6800 mode, the jumper from J80 must be moved to J68 on the back of the display.

Recommended LCD connector: 1.0mm pitch, 20-pos FFC connector

Backlight connector: JST p/n: XHP-3 **Mates with:** JST p/n: B 3B-XH-A

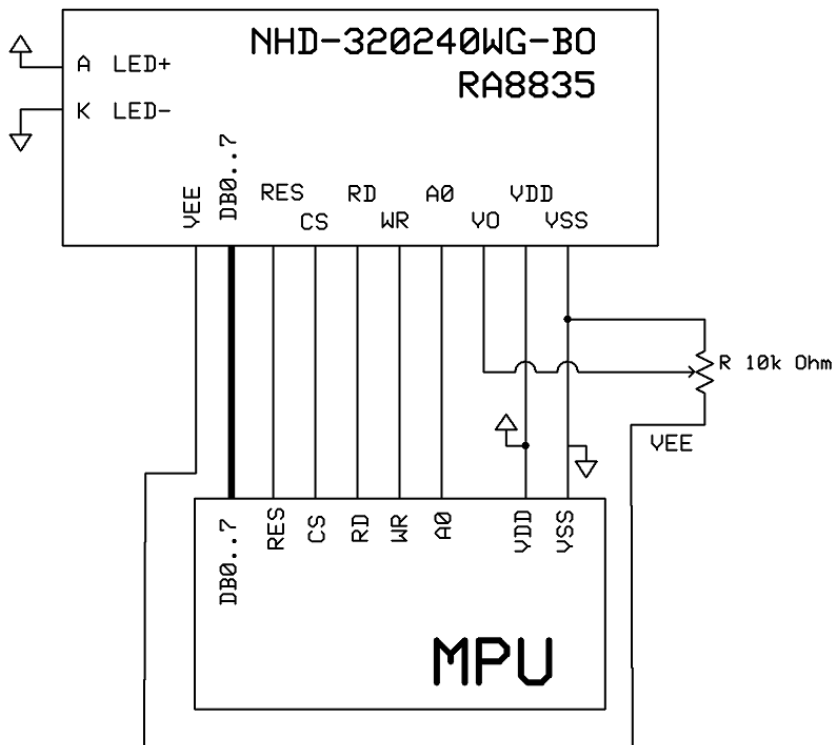

Electrical Characteristics

Item	Symbol	Condition	Min.	Typ.	Max.	Unit
Operating Temperature Range	Top	Absolute Max	-20	-	+70	°C
Storage Temperature Range	Tst	Absolute Max	-30	-	+80	°C
Supply Voltage	VDD		4.5	5.0	5.5	V
Supply Current	IDD	Ta=25°C, VDD=5.0V	-	75	-	mA
Supply for LCD (contrast)	VDD-VLCD	Ta=25°C	22.1	24.0	26.2	V
"H" Level input	VIH		0.5*VDD	-	VDD	V
"L" Level input	VIL	-	VSS	-	0.2*VDD	V
"H" Level output	VOH	-	VDD-0.4	-	-	V
"L" Level output	VOL	-	-	-	VSS+0.4	V
Backlight Supply Voltage	VLED		3.4	3.5	3.6	V
Backlight Supply Current	ILED	VLED=3.5V	115.2	128	200	mA

Optical Characteristics

Item	Symbol	Condition	Min.	Typ.	Max.	Unit
Viewing Angle – Top		Cr ≥ 3	-	40	-	°
Viewing Angle – Bottom			-	20	-	°
Viewing Angle – Left			-	30	-	°
Viewing Angle – Right			-	30	-	°
Contrast Ratio	Cr		-	3	-	-
Response Time (rise)	Tr	-	-	200	300	ms
Response Time (fall)	Tf	-	-	150	200	ms

Touch Panel Characteristics

Item	Min.	Typ.	Max.	Unit
Linearity	-	-	1.5	%
Circuit Resistance – X-Axis	350	-	1000	Ω
Circuit Resistance – Y-Axis	200	-	650	Ω
Insulation Resistance	20	-	-	MΩ
Operating Voltage	-	-	5	V
Chattering	-	-	15	ms
Transmittance	80	-	-	%
Activation Force	-	-	80	g
Pen Writing Durability	10,000	-	-	Characters
Pitting Durability	1,200,000	-	-	Touches
Surface Hardness	2	-	-	H
Haze	-	7	-	%

Controller Information

Built-in RA8835 controller.

Please download specification at http://www.newhavendisplay.com/app_notes/RA8835.pdf

Table of Commands

Class	Command	Code											Hex	Command Description
		RD	WR	A0	D7	D6	D5	D4	D3	D2	D1	D0		
System Control	SYSTEM SET	1	0	1	0	1	0	0	0	0	0	0	40	Initialize device and display
	SLEEP IN	1	0	1	0	1	0	1	0	0	1	1	53	Enter standby mode
Display Control	DISPLAY ON/OFF	1	0	1	0	1	0	1	1	0	0	D	58, 59	Enable and disable display and display flashing
	SCROLL	1	0	1	0	1	0	0	0	1	0	0	44	Set display start address and display regions
	CSRFORM	1	0	1	0	1	0	1	1	1	0	1	5D	Set cursor type
	CGRAM ADR	1	0	1	0	1	0	1	1	1	0	0	5C	Set start address of character generator RAM
	CSRDIR	1	0	1	0	1	0	0	1	1	CD 1	CD 0	4C to 4F	Set direction of cursor movement
	HDOT SCR	1	0	1	0	1	0	1	1	0	1	0	5A	Set horizontal scroll position
	OVLAY	1	0	1	0	1	0	1	1	0	1	1	5B	Set display overlay format
	Drawing Control	CSRW	1	0	1	0	1	0	0	0	1	1	0	46
CSRR		1	0	1	0	1	0	0	0	1	1	1	47	Read cursor address
Memory Control	MWRITE	1	0	1	0	1	0	0	0	0	1	0	42	Write to display memory
	MREAD	1	0	1	0	1	0	0	0	0	1	1	43	Read from display memory

Timing Characteristics

8080 Family Interface Timing

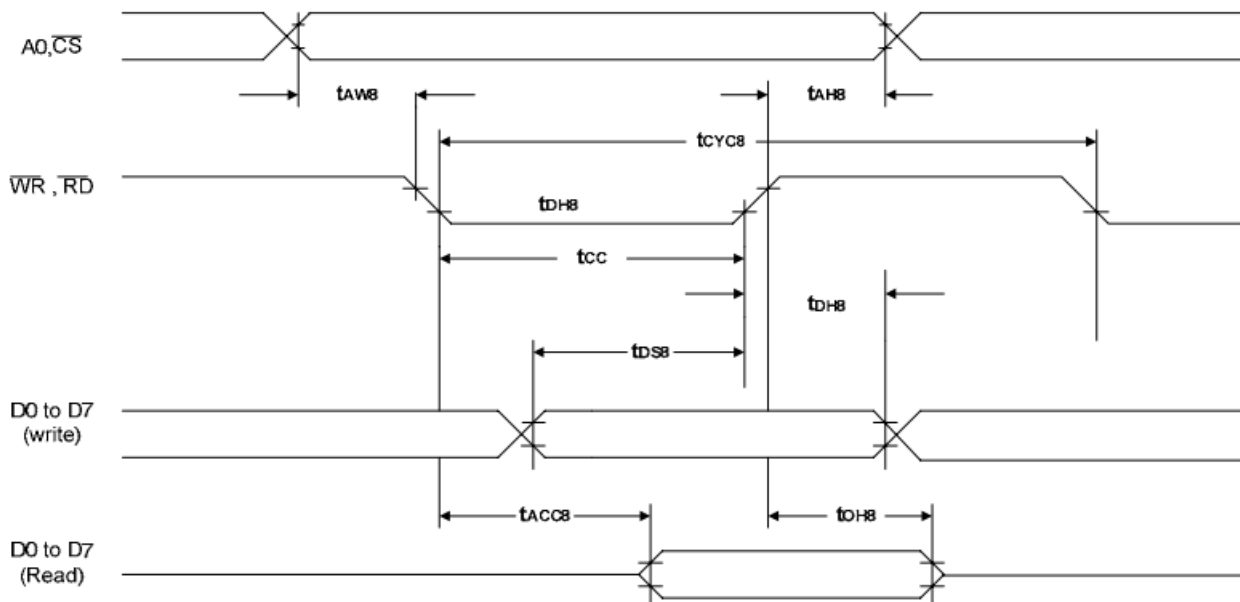

Ta = -20 to 75°C

Signal	Symbol	Parameter	V _{DD} = 4.5 to 5.5V		V _{DD} = 2.7 to 4.5V		Unit	Condition
			Min.	Max.	Min.	Max.		
A0, \overline{CS}	t_{AH8}	Address hold time	10	—	10	—	ns	CL = 100pF
	t_{AW8}	Address setup time	0	—	0	—	ns	
\overline{WR} , \overline{RD}	t_{CYC8}	System cycle time	note.	—	note.	—	ns	
	t_{CC}	Strobe pulse width	120	—	150	—	ns	
D0 to D7	t_{DS8}	Data setup time	120	—	120	—	ns	
	t_{DH8}	Data hold time	5	—	5	—	ns	
	t_{ACC8}	\overline{RD} access time	—	50	—	80	ns	
	t_{OH8}	Output disable time	10	50	10	55	ns	

Note: For memory control and system control commands:

$$t_{CYC8} = 2t_C + t_{CC} + t_{CEA} + 75 > t_{ACV} + 245$$

For all other commands:

$$t_{CYC8} = 4t_C + t_{CC} + 30$$

6800 Family Interface Timing

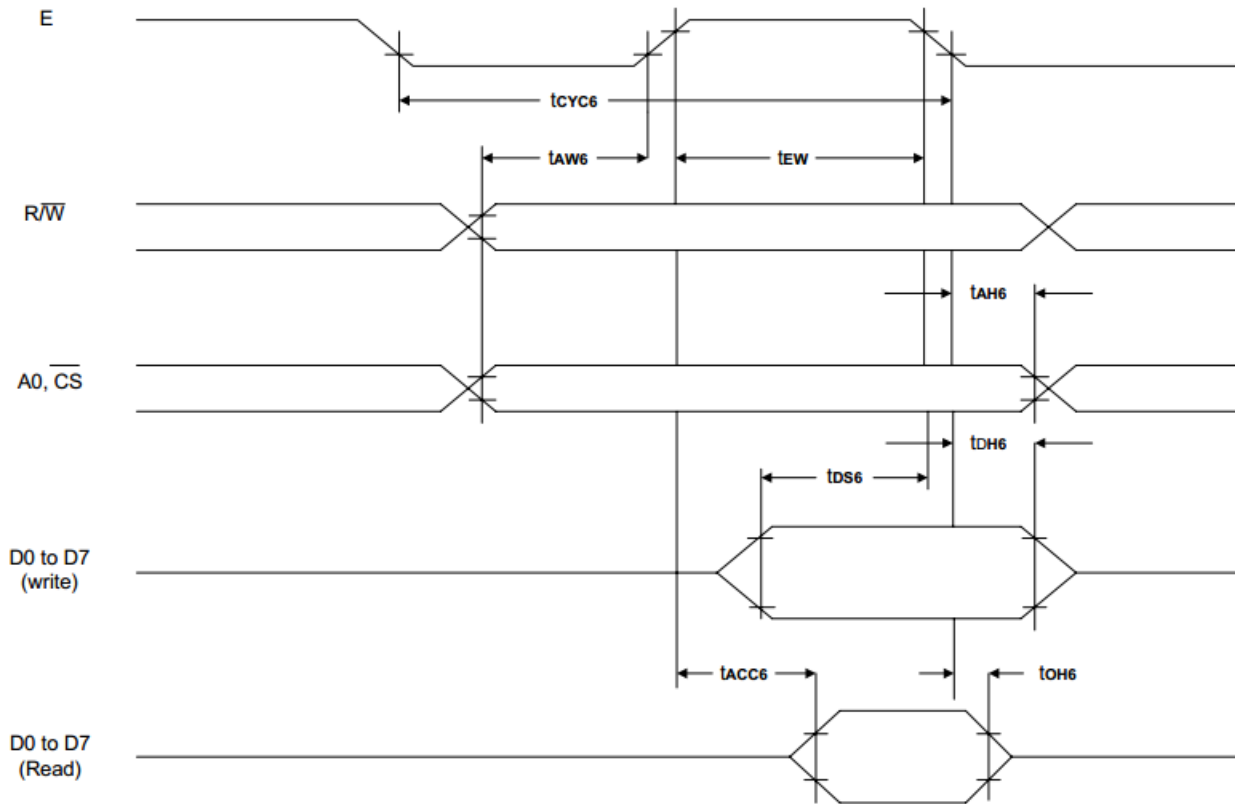

$T_a = -20 \text{ to } 75^\circ\text{C}$

Signal	Symbol	Parameter	$V_{DD} = 4.5 \text{ to } 5.5\text{V}$		$V_{DD} = 2.7 \text{ to } 4.5\text{V}$		Unit	Condition
			Min.	Max.	Min.	Max.		
A0, $\overline{\text{CS}}$, R/(W)	t_{CYC6}	System cycle time	note.	—	note.	—	ns	CL = 100 pF
	t_{AW6}	Address setup time	0	—	10	—	ns	
	t_{AH6}	Address hold time	0	—	0	—	ns	
D0 to D7	t_{DS6}	Data setup time	100	—	120	—	ns	
	t_{DH6}	Data hold time	0	—	0	—	ns	
	t_{OH6}	Output disable time	10	50	10	75	ns	
	t_{ACC6}	Access time	—	85	—	130	ns	
E	t_{EW}	Enable pulse width	120	—	150	—	ns	

Note: For memory control and system control commands:

$$t_{CYC6} = 2t_C + t_{EW} + t_{CEA} + 75 > t_{ACV} + 245$$

For all other commands:

$$t_{CYC6} = 4t_C + t_{EW} + 30$$

Example Initialization Program

```
//-----
#define A0 P3_0
#define RW P3_7
#define E P3_4
#define CS P3_1
#define RESET P3_6

//-----
void data_out(unsigned char i) //Data Output 16-bit Bus Interface
{
    A0 = 0;
    P1 = i;
    CS = 0;
    RW = 0;
    E = 1;
    delay(1);
    E = 0;
    RW = 1;
    CS = 1;
}

void comm_out(unsigned char j) //Command Output 8-bit Bus Interface
{
    A0 = 1;
    P1 = j;
    CS = 0;
    RW = 0;
    E = 1;
    delay(1);
    E = 0;
    RW = 1;
    CS = 1;
}

//-----
//          Initialization For RA8835
//-----
void resetLCD()
{
    RESET = 0;
    delay(5);
    RESET = 1;
    delay(10);
}

void init_LCD()
```

```
{  
comm_out(0x40);  
delay(5);  
data_out(0x34);  
data_out(0x87);  
data_out(0x07);  
data_out(0x27);  
data_out(0x39);  
data_out(0xEF);  
data_out(0x28);  
data_out(0x00);  
comm_out(0x44);  
data_out(0x00);  
data_out(0x00);  
data_out(0xEF);  
data_out(0xB0);  
data_out(0x04);  
data_out(0xEF);  
data_out(0x00);  
data_out(0x00);  
data_out(0x00);  
data_out(0x00);  
comm_out(0x5A);  
data_out(0x00);
```

Quality Information

Test Item	Content of Test	Test Condition	Note
High Temperature storage	Endurance test applying the high storage temperature for a long time.	+80°C , 200hrs	2
Low Temperature storage	Endurance test applying the low storage temperature for a long time.	-30°C , 200hrs	1,2
High Temperature Operation	Endurance test applying the electric stress (voltage & current) and the high thermal stress for a long time.	+70°C 200hrs	2
Low Temperature Operation	Endurance test applying the electric stress (voltage & current) and the low thermal stress for a long time.	-20°C , 200hrs	1,2
High Temperature / Humidity Operation	Endurance test applying the electric stress (voltage & current) and the high thermal with high humidity stress for a long time.	+60°C , 90% RH , 96hrs	1,2
Thermal Shock resistance	Endurance test applying the electric stress (voltage & current) during a cycle of low and high thermal stress.	-20°C,30min -> 25°C,5min -> 70°C,30min = 1 cycle 10 cycles	
Vibration test	Endurance test applying vibration to simulate transportation and use.	10-55Hz , 15mm amplitude. 60 sec in each of 3 directions X,Y,Z For 15 minutes	3
Static electricity test	Endurance test applying electric static discharge.	VS=800V, RS=1.5kΩ, CS=100pF One time	

Note 1: No condensation to be observed.

Note 2: Conducted after 4 hours of storage at 25°C, 0%RH.

Note 3: Test performed on product itself, not inside a container.

Precautions for using LCDs/LCMs

See Precautions at www.newhavendisplay.com/specs/precautions.pdf

Warranty Information and Terms & Conditions

http://www.newhavendisplay.com/index.php?main_page=terms