

User's Guide

NHD-320240WG-BFMI-VZ

LCM

(Liquid Crystal Display Graphic Module)

RoHS Compliant

NHD-	Newhaven Display
320240-	320 x 240 pixels
WG-	W- Version Line G- Display Mode: Graphic
B-	Model/Serial Number
F-	White CCFL B/L
M-	STN-(negative)Blue
I-	Transmissive, 6:00 View, Wide Temperature (-20 ~ +70c)
VZ-	Build in Negative voltage ; Controller: SED 1335

For product support, contact

Newhaven Display International
2511 Technology Drive, #101
Elgin, IL 60124

Tel: (847) 844-8795 Fax: (847) 844-8796

March 12, 2009

Contents

1. Module classification information
2. Precautions in Use of LCM
3. General Specification
4. Absolute Maximum Ratings
5. Electrical Characteristics
6. Optical Characteristics
7. Interface Description
8. Contour Drawing & Block Diagram
9. Quality Assurance
10. Reliability
11. Backlight Information

1. Module Classification Information

NHD 320240 W G - B F M I - VZ
 ① ② ③ ④ ⑤ ⑥ ⑦ ⑧ 9

- ① Brand : Newhaven Display
- ② Display Font : 320 x 240 Dots
- ③ Factory Line: W
- ④ Display Type : H→Character Type, G→Graphic Type, C→ Color
- ⑤ Model / Serial number = **B**
- ⑥ Backlight Type :
- | | |
|-----------------------|---------------|
| N→Without backlight | T→LED, White |
| B→EL, Blue green | A→LED, Amber |
| D→EL, Green | R→LED, Red |
| W→EL, White | O→LED, Orange |
| F →CCFL, White | G→LED, Green |
| Y→LED, Yellow Green | |
- ⑦ LCD Mode :
- | | |
|------------------------------|-----------------|
| B→TN Positive, Gray | T→FSTN Negative |
| N→TN Negative, | C→STN Color |
| G→STN Positive, Gray | |
| Y→STN Positive, Yellow Green | |
| M →STN Negative, Blue | |
| F→FSTN Positive | |
- ⑧ LCD Polarize Type/
 Temperature range/
 View direction
- | | |
|----------------------------|------------------------------------|
| A→Reflective, N.T, 6:00 | H→Transflective, W.T,6:00 |
| D→Reflective, N.T, 12:00 | K→Transflective,
W.T,12:00 |
| G→Reflective, W. T, 6:00 | C→Transmissive, N.T,6:00 |
| J→Reflective, W. T, 12:00 | F→Transmissive, N.T,12:00 |
| B→Transflective, N.T,6:00 | I →Transmissive, W. T, 6:00 |
| E→Transflective, N.T.12:00 | L→Transmissive, W.T,12:00 |
- 9 Special Code **VZ** : Build in Negative voltage ; Controller: SED 1335

2. Precautions in Use of LCD Module

- (1) Avoid applying excessive shock to the module or making any alterations or modifications to it.

- (2) Don't make extra holes on the printed circuit board, modify its shape or change the components of LCD Module.
- (3) Don't disassemble the LCM.
- (4) Don't operate it above the absolute maximum rating.
- (5) Don't drop, bend or twist LCM.
- (6) Soldering: only to the I/O terminals.
- (7) Storage: please store in anti-static electricity container and clean environment.

3. General Specification for **NHD-320240WG-BFMI-VZ**

ITEM	STANDARD VALUE	UNIT
Number of dots	320x240	dots
Outline dimension	166.8(W) x 109.0(H) x 13.0max(T)	mm
View area	122.0(W) x 92.0(H)	mm
Active area	115.18(W) x 86.38(H)	mm
Dot size	0.34(W) x 0.34(H)	mm
Dot pitch	0.36(W) x 0.36(H)	mm
LCD type	STN- BLUE negative, Transmissive	
View direction	6 o'clock	
Backlight	CCFL, White	

4. Absolute Maximum Ratings

ITEM	SYMBOL	MIN.	TYP.	MAX.	UNIT
Operating Temperature	T_{OP}	-20	—	+70	°C
Storage Temperature	T_{ST}	-30	—	+80	°C
Input Voltage	V_I	0	—	V_{DD}	V
Supply Voltage For Logic	V_{DD}	0	—	6.5	V
Supply Voltage For LCD	$V_{DD}-V_{EE}$	0	—	32	V

5. Electrical Characteristics

ITEM	SYMBOL	CONDITION	MIN.	TYP.	MAX.	UNIT
Logic Voltage	$V_{DD}-V_{SS}$	—	—	5.0	5.5	V
Supply Voltage For LCD	$V_{DD}-V_O$	$T_a=-20^{\circ}\text{C}$	—	—	26.0	V
		$T_a=25^{\circ}\text{C}$	—	24.0	—	V
		$T_a=+70^{\circ}\text{C}$	22.0	—	—	V
Input High Volt.	V_{IH}	—	$0.8V_{DD}$	—	V_{DD}	V
Input Low Volt.	V_{IL}	—	0	—	$0.2V_{DD}$	V
Output High Volt.	V_{OH}	—	$V_{DD}-0.4$	—	—	V
Output Low Volt.	V_{OL}	—	—	—	0.4	V
Supply Current	I_{DD}	—	95.0	100.0	110.0	mA

6. Optical Characteristics

ITEM	SYMBOL	CONDITION	MIN	TYP	MAX	UNIT
View Angle	(V) θ	$CR \geq 2$	10	—	105	deg.
	(H) φ	$CR \geq 2$	-30	—	30	deg.
Contrast Ratio	CR	—	—	3	—	—
Response Time	T rise	—	—	200	300	ms
	T fall	—	—	150	200	ms

6.1 Definitions

■ View Angles

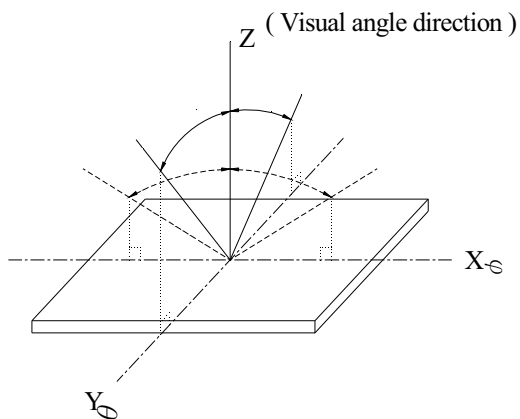

■ Contrast Ratio

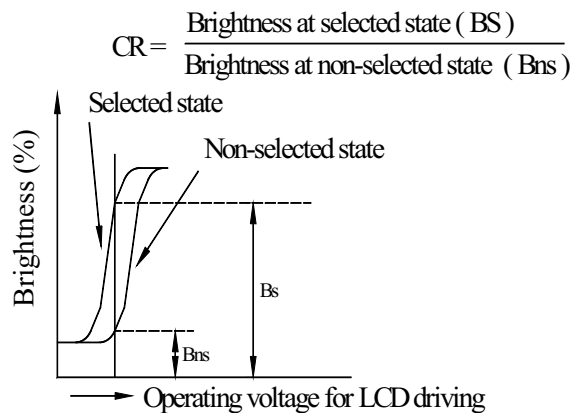

■ Response time

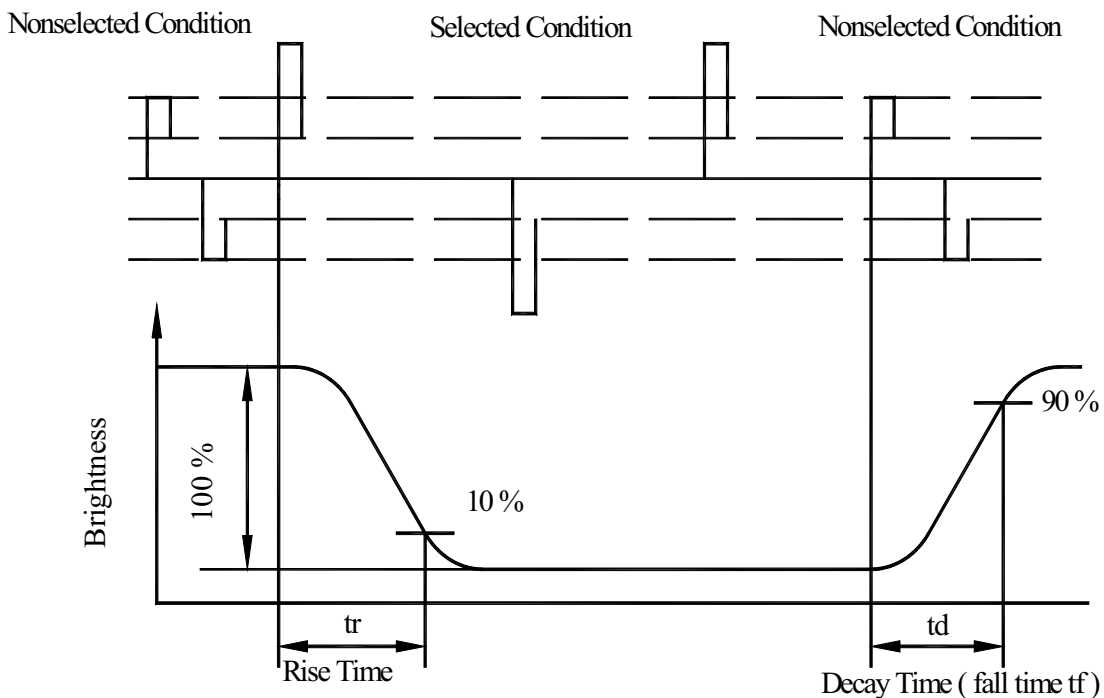

7. Interface Description

Pin No.	Symbol	Level	Description
1	V _{SS}	0V	Ground
2	V _{DD}	5.0V	Power supply for Logic
3	V _O	(Variable)	Driving voltage for LCD
4	A0	H/L	RD=L WR=H , A0=L :Data Read AO=H :Status read RD=H WR=L , A0=L :Data Write AO=H :Command write
5	$\overline{\text{WR}}$	H/L	8080 family MPU interface: Write signal
6	$\overline{\text{RD}}$	H/L	8080 family MPU interface: Read signal
7~14	DB0~DB7	H/L	Data bus
15	$\overline{\text{CS}}$	H/L	Chip select, Active L
16	$\overline{\text{RES}}$	H/L	Controller reset signal, Active L
17	V _{EE}	-25V	Negative voltage output (Optional)
18	SEL1		NC (6800 series MPU interface option) *Note1
19	(FGND)		NC (Frame Ground option)
20	NC		No connection

Note1: Setup by hardware

8. Contour Drawing & Block diagram

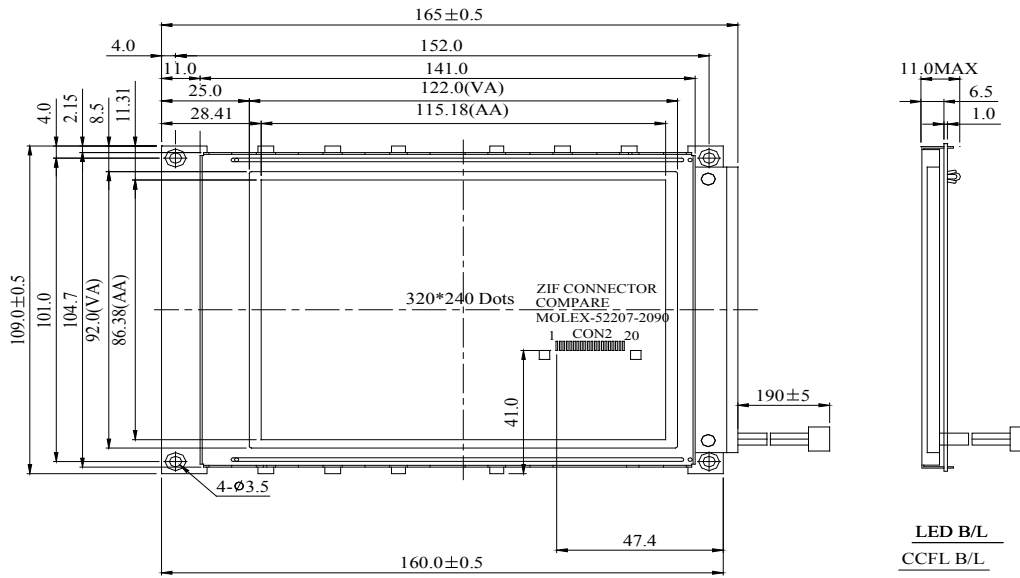

PIN NO.	SYMBOL
1	V _{ss}
2	V _{dd}
3	V _o
4	A0
5	WR
6	RD
7	DB0
8	DB1
9	DB2
10	DB3
11	DB4
12	DB5
13	DB6
14	DB7
15	CS
16	RES
17	V _{ee}
18	SEL1
19	FGND
20	NC

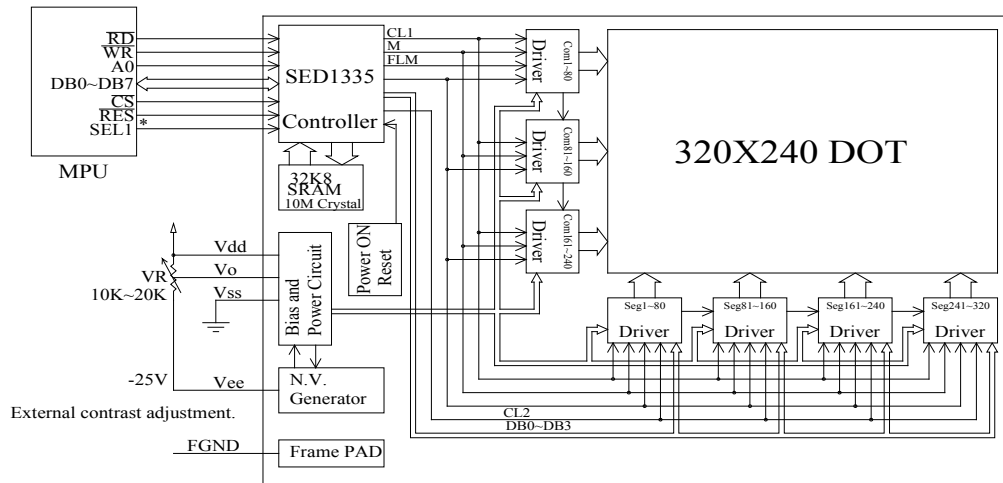
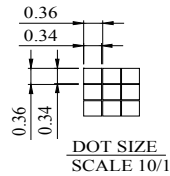

Led B/L drive directly from connector .

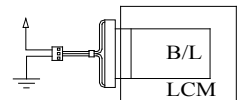

*:6800 family or 8080family interface selectable.

9. Quality Assurance

◆ Screen Cosmetic Criteria

No.	Defect	Judgement Criteria	Partition																				
1	Spots	<p>A) Clear</p> <table border="1"> <thead> <tr> <th>Size: d mm</th> <th>Acceptable Qty in active area</th> </tr> </thead> <tbody> <tr> <td>$d \leq 0.1$</td> <td>Disregard</td> </tr> <tr> <td>$0.1 < d \leq 0.2$</td> <td>6</td> </tr> <tr> <td>$0.2 < d \leq 0.3$</td> <td>2</td> </tr> <tr> <td>$0.3 < d$</td> <td>0</td> </tr> </tbody> </table> <p>Note: Including pin holes and defective dots which must be within one pixel size.</p> <p>B) Unclear</p> <table border="1"> <thead> <tr> <th>Size: d mm</th> <th>Acceptable Qty in active area</th> </tr> </thead> <tbody> <tr> <td>$d \leq 0.2$</td> <td>Disregard</td> </tr> <tr> <td>$0.2 < d \leq 0.5$</td> <td>6</td> </tr> <tr> <td>$0.5 < d \leq 0.7$</td> <td>2</td> </tr> <tr> <td>$0.7 < d$</td> <td>0</td> </tr> </tbody> </table>	Size: d mm	Acceptable Qty in active area	$d \leq 0.1$	Disregard	$0.1 < d \leq 0.2$	6	$0.2 < d \leq 0.3$	2	$0.3 < d$	0	Size: d mm	Acceptable Qty in active area	$d \leq 0.2$	Disregard	$0.2 < d \leq 0.5$	6	$0.5 < d \leq 0.7$	2	$0.7 < d$	0	Minor
Size: d mm	Acceptable Qty in active area																						
$d \leq 0.1$	Disregard																						
$0.1 < d \leq 0.2$	6																						
$0.2 < d \leq 0.3$	2																						
$0.3 < d$	0																						
Size: d mm	Acceptable Qty in active area																						
$d \leq 0.2$	Disregard																						
$0.2 < d \leq 0.5$	6																						
$0.5 < d \leq 0.7$	2																						
$0.7 < d$	0																						
2	Bubbles in Polarize	<table border="1"> <thead> <tr> <th>Size: d mm</th> <th>Acceptable Qty in active area</th> </tr> </thead> <tbody> <tr> <td>$d \leq 0.3$</td> <td>Disregard</td> </tr> <tr> <td>$0.3 < d \leq 1.0$</td> <td>3</td> </tr> <tr> <td>$1.0 < d \leq 1.5$</td> <td>1</td> </tr> <tr> <td>$1.5 < d$</td> <td>0</td> </tr> </tbody> </table>	Size: d mm	Acceptable Qty in active area	$d \leq 0.3$	Disregard	$0.3 < d \leq 1.0$	3	$1.0 < d \leq 1.5$	1	$1.5 < d$	0	Minor										
Size: d mm	Acceptable Qty in active area																						
$d \leq 0.3$	Disregard																						
$0.3 < d \leq 1.0$	3																						
$1.0 < d \leq 1.5$	1																						
$1.5 < d$	0																						
3	Scratch	In accordance with spots cosmetic criteria. When the light reflects on the panel surface, the scratches are not to be remarkable.	Minor																				
4	Allowable Density	Above defects should be separated more than 30mm each other.	Minor																				
5	Coloration	Not to be noticeable coloration in the viewing area of the LCD panels. Back-light type should be judged with back-light on state only.	Minor																				

10. RELIABILITY

Content of Reliability Test

Environmental Test				
No.	Test Item	Content of Test	Test Condition	Applicable Standard
1	High Temperature storage	Endurance test applying the high storage temperature for a long time.	80°C 200hrs	—
2	Low Temperature storage	Endurance test applying the high storage temperature for a long time.	-30°C 200hrs	—
3	High Temperature Operation	Endurance test applying the electric stress (Voltage & Current) and the thermal stress to the element for a long time.	70°C 200hrs	—
4	Low Temperature Operation	Endurance test applying the electric stress under low temperature for a long time.	-20°C 200hrs	—
5	High Temperature/ Humidity Storage	Endurance test applying the high temperature and high humidity storage for a long time.	80°C, 90%RH 96hrs	—
6	High Temperature/ Humidity Operation	Endurance test applying the electric stress (Voltage & Current) and temperature / humidity stress to the element for a long time.	70°C, 90%RH 96hrs	—
7	Temperature Cycle	Endurance test applying the low and high temperature cycle. $ \begin{array}{c} -30^{\circ}\text{C} \quad 25^{\circ}\text{C} \quad 80^{\circ}\text{C} \\ \longleftarrow \hspace{1cm} \longrightarrow \\ 30\text{min} \quad 5\text{min} \quad 30\text{min} \\ \hline 1 \text{ cycle} \end{array} $	-30°C/80°C 10 cycles	—
Mechanical Test				
8	Vibration test	Endurance test applying the vibration during transportation and using.	10~22Hz→1.5mmp-p 22~500Hz→1.5G Total 0.5hrs	—
9	Shock test	Constructional and mechanical endurance test applying the shock during transportation.	50G Half sign wave 11 msdc 3 times of each direction	—
10	Atmospheric pressure test	Endurance test applying the atmospheric pressure during transportation by air.	115mbar 40hrs	—
Others				
11	Static electricity test	Endurance test applying the electric stress to the terminal.	VS=800V, RS=1.5kΩ CS=100pF 1 time	—

***Supply voltage for logic system=5V. Supply voltage for LCD system =Operating voltage at 25°C

11. Backlight Information

CCFL backlight Specification

(Ta=25°C)

Item	Symbol	Specification			Unit	Condition
		Min	Typ	Max		
Driving Voltage	V _{FL}	—	278	—	Vrms	—
Input current	I _{FL}	3.0	5.0	6.0	mArms	—
Power consumption	W	—	1.35	—	W	—
Starting Voltage	V _{FLS}	—	530	—	Vrms	—
Luminance	L	—	550	—	Cd/m ²	$\varphi, \theta = 0 \text{ deg}, I_{FL} = 5.0 \text{ mArms}$
Chromaticity	x	—	0.340	—	—	—
	y	—	0.370	—	—	—
Luminance Uniformity (Testing 9 point)	—	75%	—	—	%	$\varphi, \theta = 0 \text{ deg}, I_{FL} = 5.0 \text{ mArms}$
Life time	—	20,000	—	—	hrs	