

# NHD-12864WX-T1TFH#

## Graphic Liquid Crystal Display Module

NHD-	Newhaven Display
12864-	128 x 64 pixels
WX-	Display Type: Graphic, Tab Type
T1-	Model
T-	White LED Backlight
F-	FSTN (+)
H-	Transflective, Wide Temp (-20°C ~ +70°C), 6:00 optimal view
#-	<b>RoHS Compliant</b>

**Newhaven Display International, Inc.**

2511 Technology Drive, Suite 101

Elgin IL, 60124

Ph: 847-844-8795

Fax: 847-844-8796

[www.newhavendisplay.com](http://www.newhavendisplay.com)

[nhtech@newhavendisplay.com](mailto:nhtech@newhavendisplay.com)

[nhsales@newhavendisplay.com](mailto:nhsales@newhavendisplay.com)

## Document Revision History

Revision	Date	Description	Changed by
0	8/22/2008	Initial Release	-
1	10/22/2008	Backlight modification	-
2	3/17/2010	User guide reformat	BE
3	4/14/2010	Block diagram/initialization updated	BE
4	5/12/2010	Pin description updated	BE
5	9/21/2012	Mechanical drawing & Pin description updated	AK
6	8/5/2013	Mechanical drawing & optical characteristics updated	ML

## Functions and Features

- 128 x 64 pixels
- Built-in NT7534H Controller
- +3.3V power supply
- 1/64 duty cycle
- Parallel or Serial Interface
- RoHS Compliant

# Mechanical Drawing

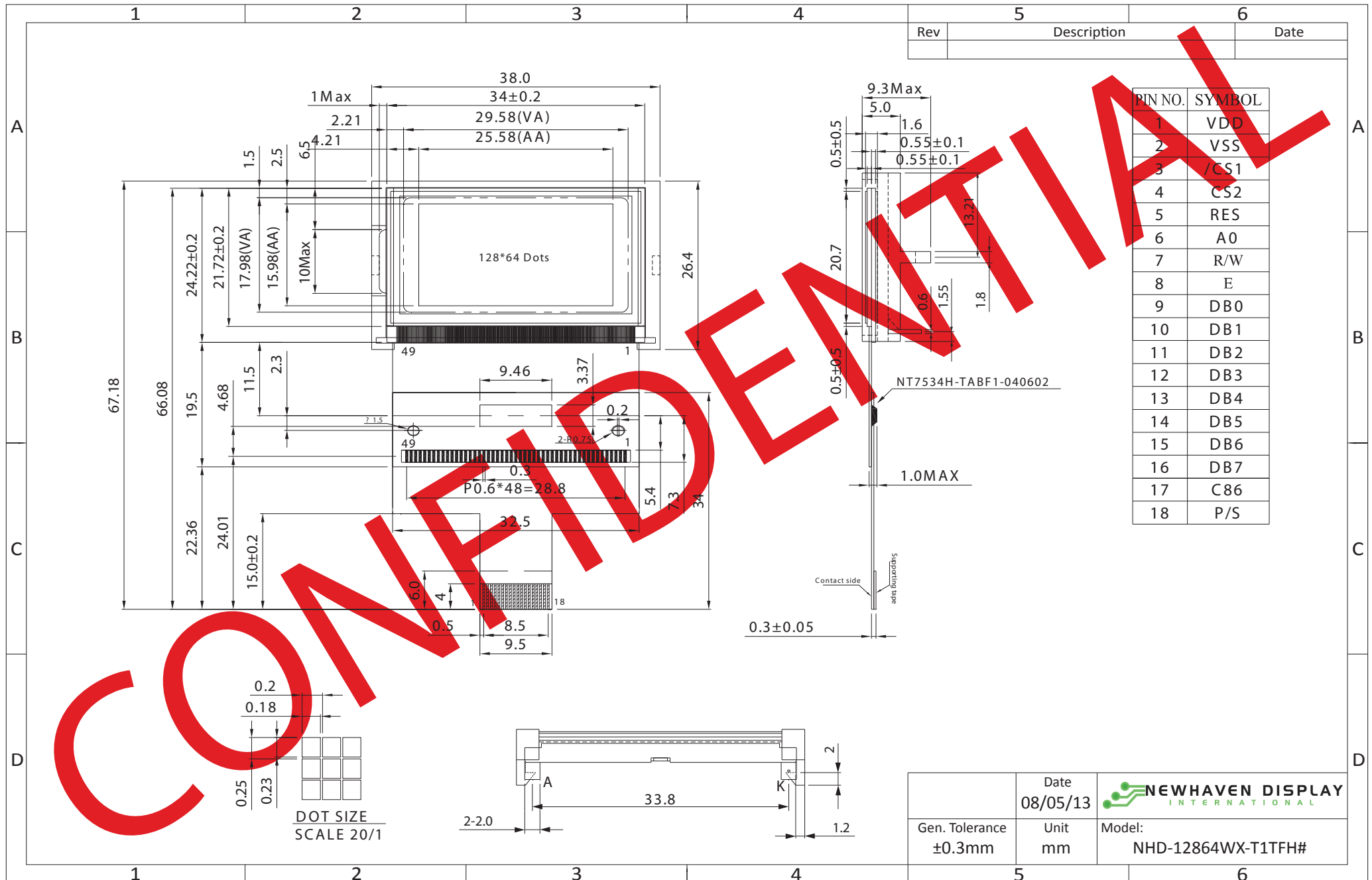

The drawing contained herein is the exclusive property of Newhaven Display International, Inc. and shall not be copied, reproduced, and/or disclosed in any format without permission.

## Pin Description and Wiring Diagram

Pin No.	Symbol	External Connection	Function Description
1	VDD	Power Supply	Power supply for logic (+3.3V)
2	VSS	Power Supply	Ground
3	/CS1	MPU	Active LOW Chip Select Signal
4	CS2	MPU	Active HIGH Chip Select Signal
5	RES	MPU	Active LOW Reset signal
6	A0	MPU	Register Select. 0: instruction; 1: data
7	R/W	MPU	Read/Write select signal. R/W=1: Read R/W=0: Write
8	E	MPU	Operation enable signal. Falling edge triggered.
9-16	DB0-DB7	MPU	Bi-directional 8-bit data bus
17	C86	MPU	Select MPU interface pin. C86 = H: 6800; C86 = L: 8080
18	P/S	MPU	Parallel/Serial select. PS = H: Parallel; PS = L: Serial
A	LED+	Power Supply	Power supply for LED Backlight (+3.5V)
K	LED-	Power Supply	Ground for Backlight

**Recommended LCD connector:** 0.6mm pitch, 18 pin FFC. Molex p/n: 52892-1895

**Backlight connector:** - Mates with: -

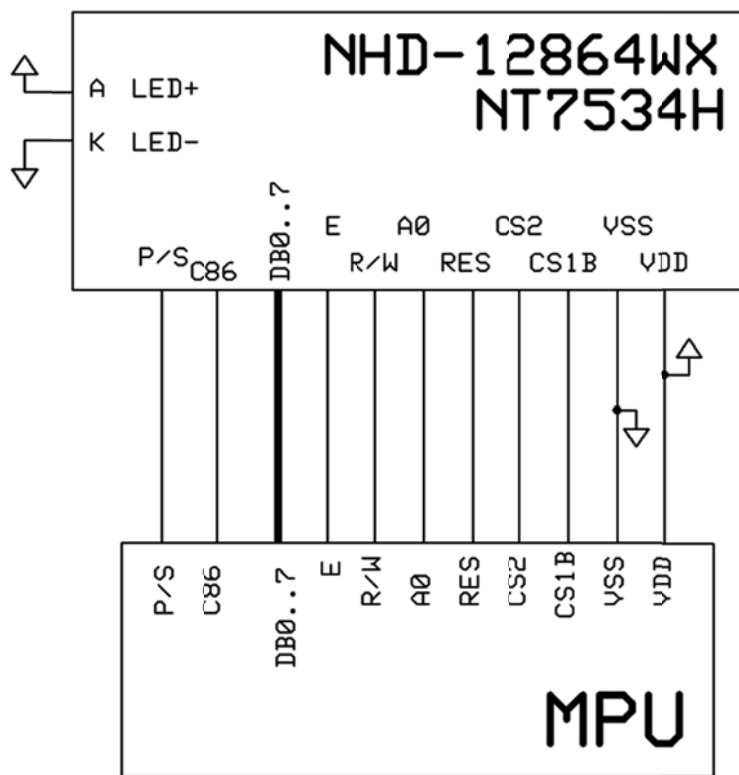

## Electrical Characteristics

Item	Symbol	Condition	Min.	Typ.	Max.	Unit
Operating Temperature Range	Top	Absolute Max	-20	-	+70	°C
Storage Temperature Range	Tst	Absolute Max	-30	-	+80	°C
Supply Voltage	VDD		3.0	3.3	3.6	V
Supply Current	IDD	-	-	0.18	-	mA
Supply for LCD (contrast)	VDD-V0	Ta=25°C	-	9.0	-	V
"H" Level input	VIH		0.8*VDD	-	VDD	V
"L" Level input	VIL	-	VSS	-	0.2*VDD	V
"H" Level output	VOH	-	0.8*VDD	-	VDD	V
"L" Level output	VOL	-	VSS	-	0.2*VDD	V
Backlight Supply Voltage	VLED	-	3.4	3.5	3.6	V
Backlight Supply Current	ILED	VLED=3.5V	28.8	32	50	mA

## Optical Characteristics

Item	Symbol	Condition	Min.	Typ.	Max.	Unit
Viewing Angle - Top		Cr ≥ 2	-	30	-	°
Viewing Angle - Bottom			-	60	-	°
Viewing Angle - Left			-	45	-	°
Viewing Angle - Right			-	45	-	°
Contrast Ratio	Cr		-	5	-	-
Response Time (rise)	Tr	-	-	150	200	ms
Response Time (fall)	Tf	-	-	150	200	ms

## Controller Information

Built-in NT7534H controller.

Please download specification at [http://www.newhavendisplay.com/app\\_notes/NT7534.pdf](http://www.newhavendisplay.com/app_notes/NT7534.pdf)

## Table of Commands

Command	A0	/RD	/WR	Code								Hex	Function	
				D7	D6	D5	D4	D3	D2	D1	D0			
(1) Display OFF	0	1	0	1	0	1	0	1	1	1	0	1	AEh AFh	Turn on LCD panel when high, and turn off when low
(2) Display Start Line Set	0	1	0	0	1	Display Start Address					40h to 7Fh	Specifies RAM display line for COM0		
(3) Page Address Set	0	1	0	1	0	1	1	Page Address			B0h to B8h	Set the display data RAM page in Page Address register		
(4) Column Address Set	0	1	0	0	0	0	1	Higher Column Address			00h to 18h	Set 4 higher bits and 4 lower bits of column address of display data RAM in register		
	0	1	0	0	0	0	0	Lower Column Address						
(5) Read Status	0	0	1	Status				0	0	0	0	XX	Reads the status information	
(6) Write Display Data	1	1	0	Write Data								XX	Write data in display data RAM	
(7) Read Display Data	1	0	1	Read Data								XX	Read data from display data RAM	
(8) ADC Select	0	1	0	1	0	1	0	0	0	0	0	1	A0h A1h	Set the display data RAM address SEG output correspondence
(9) Normal/Reverse Display	0	1	0	1	0	1	0	0	1	1	0	1	A6h A7h	Normal indication when low, but full indication when high
(10) Entire Display ON/OFF	0	1	0	1	0	1	0	0	1	0	0	1	A4h A5h	Select normal display (0) or entire display on
(11) LCD Bias Set	0	1	0	1	0	1	0	0	0	1	0	1	A2h A3h	Sets LCD driving voltage bias ratio
(12) Read-Modify-Write	0	1	0	1	1	1	0	0	0	0	0	0	E0h	Increments column address counter during each write
(13) End	0	1	0	1	1	1	0	1	1	1	0	0	EEh	Releases the Read-Modify-Write
(14) Reset	0	1	0	1	1	1	0	0	0	1	0	0	E2h	Resets internal functions
(15) Common Output Mode Select	0	1	0	1	1	0	0	0	1	*	*	*	C0h to CFh	Select COM output scan direction *: invalid data
(16) Power Control Set	0	1	0	0	0	1	0	1	Operation Status			28h to 2Fh	Select the power circuit operation mode	
(17) V0 Voltage Regulator Internal Resistor ratio Set	0	1	0	0	0	1	0	0	Resistor Ratio			20h to 27h	Select internal resistor ratio Rb/Ra mode	
(18) Electronic Volume mode Set	0	1	0	1	0	0	0	0	0	0	0	1	81h	
Electronic Volume Register Set	0	1	0	*	*	Electronic Control Value					XX	Sets the V0 output voltage electronic volume register		
(19) Set Static indicator ON/OFF	0	1	0	1	0	1	0	1	1	0	0	1	ACH ADh	Sets static indicator ON/OFF 0: OFF, 1: ON
Set Static Indicator Register	0	1	0	*	*	*	*	*	*	Mode		XX	Sets the flash mode	
(20) Power Save	0	1	0	-	-	-	-	-	-	-	-	-	-	Compound command of Display OFF and Entire Display ON
(21) NOP	0	1	0	1	1	1	0	0	0	1	1	1	E3h	Command for non-operation

Command	A0	/RD	/WR	Code									Hex	Function
				D7	D6	D5	D4	D3	D2	D1	D0			
(22)Oscillation Frequency Select	0	1	0	1	1	1	0	0	1	0	0	E4h E5h	Select the oscillation frequency	
(23)Partial Display mode Set	0	1	0	1	0	0	0	0	0	1	0	82h 83h	Enter/Release the partial display mode	
(24)Partial Display Duty Set	0	1	0	0	0	1	1	0	Duty Ratio			30h 37h	Sets the LCD duty ratio for partial display mode	
(25)Partial Display Bias Set	0	1	0	0	0	1	1	1	Bias Ratio			38h 3Fh	Sets the LCD bias ratio for partial display mode	
(26)Partial Start Line Set	0	1	0	1	1	0	1	0	0	1	1	D3h	Enter Partial Start Line Set	
Partial Start Line Set	0	1	0	1	1	Partial Start Line					XX	Sets the LCD Number of partial display start line		
(27)N-Line Inversion Set	0	1	0	1	0	0	0	0	1	0	1	85h	Enter N-Line inversion	
Number of Line Set	0	1	0	*	*	*	Number of Line				XX	Sets the number of line used for N-Line inversion		
(28)N-Line Inversion Release	0	1	0	1	0	0	0	0	1	0	0	84h	Exit N-Line Inversion	
(29)DC/DC Clock Set	0	1	0	1	1	1	0	0	1	1	0	E6h	Set DC/DC Clock Frequency	
DC/DC Clock Division Set	0	1	0	1	1	0	0	Clock Division			XX	Set the Division of DC/DC Clock Frequency		
(30)Test Command	0	1	0	1	1	1	1	*	*	*	*	F1h to FFh	IC test command. Do not use!	
(31)Test Mode Reset	0	1	0	1	1	1	1	0	0	0	0	F0h	Command of test mode reset	

Note: Do not use any other command, or system malfunction may result.

## Timing Characteristics

### System Buses Read/Write Characteristics (for 8080 Series MPU)

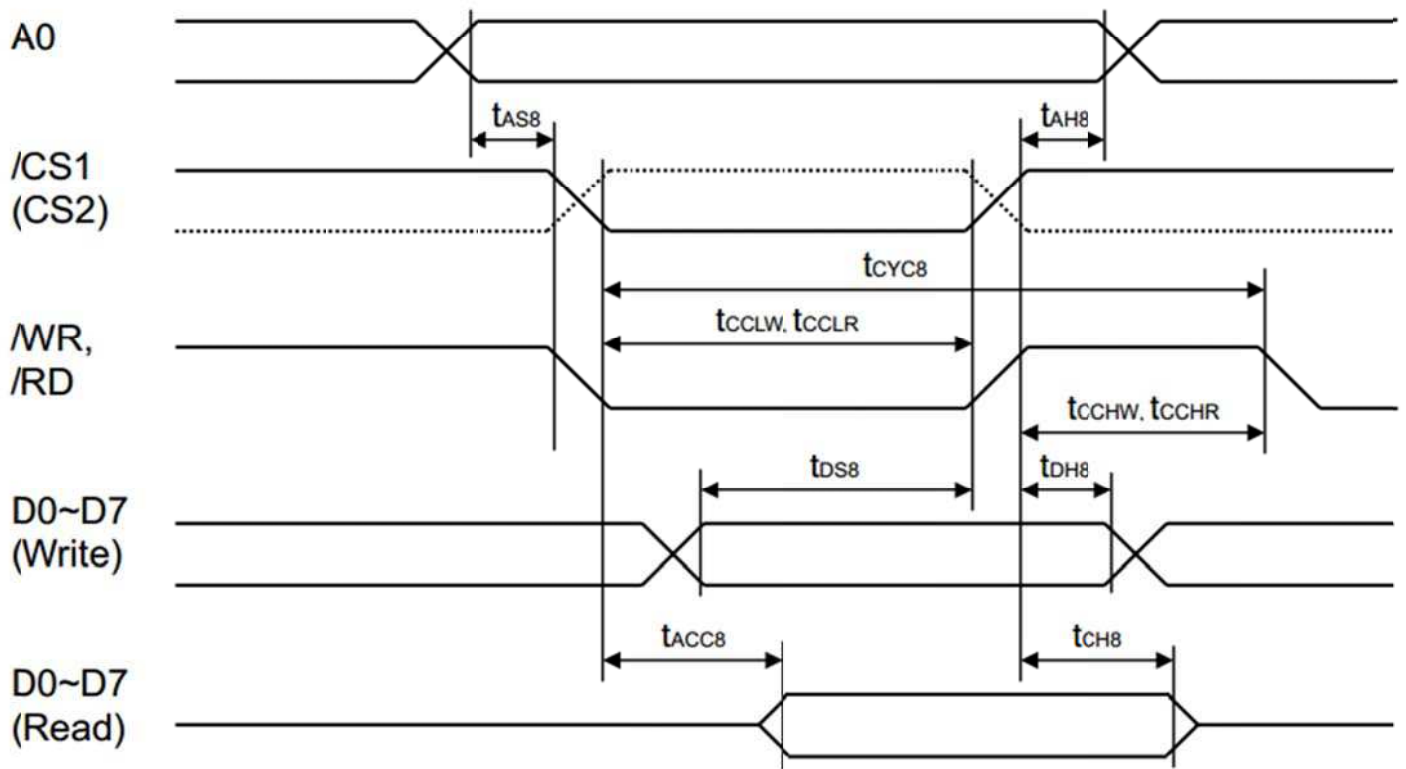

(VDD = 2.7 ~ 3.6V, Ta = -40 ~ +85°C)

Symbol	Parameter	Min.	Typ.	Max.	Unit	Condition
$T_{AH8}$	Address hold time	0	-	-	ns	A0
$T_{AS8}$	Address setup time	0	-	-	ns	
$t_{CYC8}$	System cycle time	240	-	-	ns	
$t_{CCLW}$	Control low pulse width (write)	90	-	-	ns	/WR
$t_{CCLR}$	Control low pulse width (read)	120	-	-	ns	/RD
$t_{CCHW}$	Control high pulse width (write)	100	-	-	ns	/WR
$t_{CCHR}$	Control high pulse width (read)	60	-	-	ns	/RD
$T_{DS8}$	Data setup time	40	-	-	ns	D0~D7
$T_{DH8}$	Data hold time	10	-	-	ns	
$t_{ACC8}$	/RD access time	-	-	140	ns	D0~D7, CL = 100pF
$T_{CH8}$	Output disable time	5	-	50	ns	

## System Buses Read/Write Characteristics (for 6800 Series MPU)

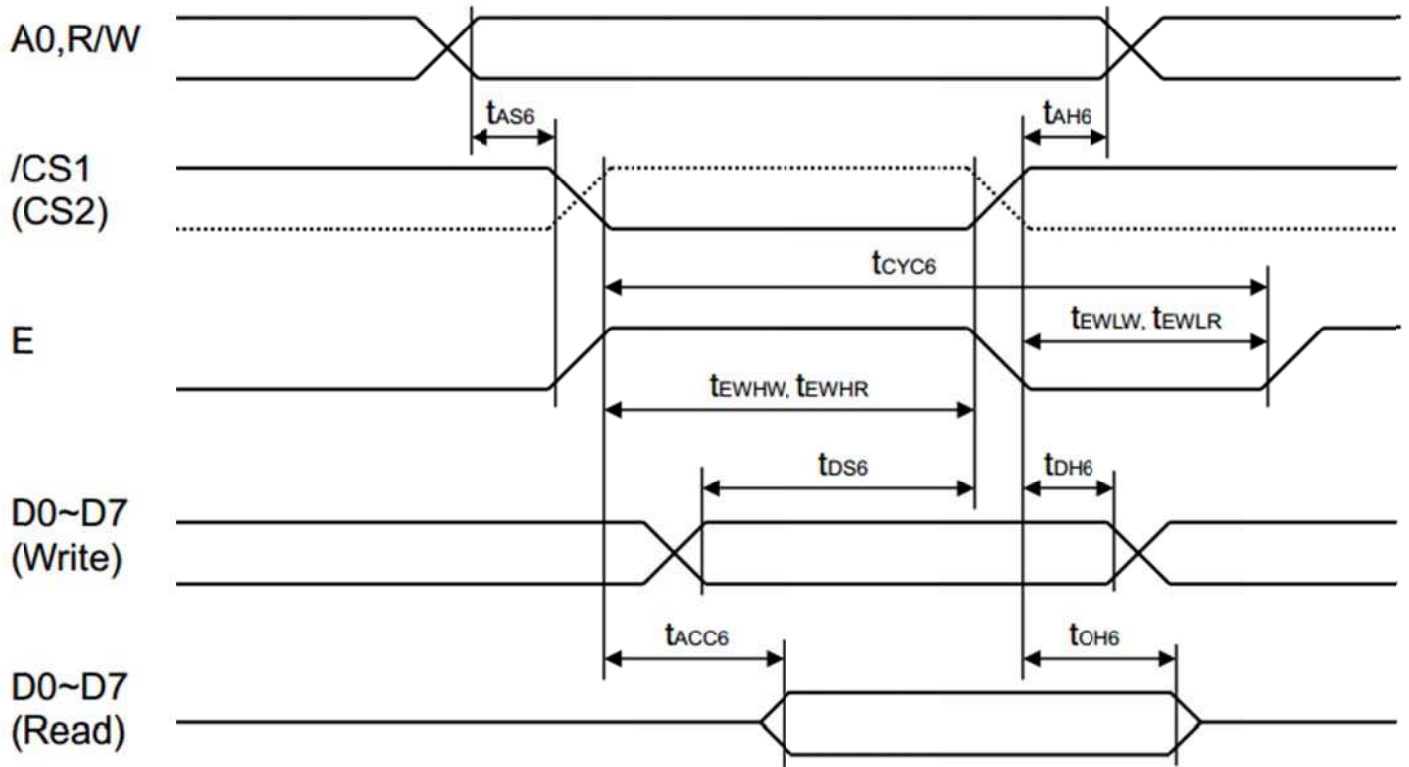

(VDD = 2.7 ~ 3.6V, Ta = -40 ~ +85°C)

Symbol	Parameter	Min.	Typ.	Max.	Unit	Condition
$t_{AH6}$	Address hold time	0	-	-	ns	A0, R/W
$t_{AS6}$	Address setup time	0	-	-	ns	
$t_{CYC6}$	System cycle time	240	-	-	ns	
$t_{EWHW}$	Control high pulse width (write)	90	-	-	ns	E
$t_{EWHR}$	Control high pulse width (read)	120	-	-	ns	E
$t_{EWLW}$	Control low pulse width (write)	100	-	-	ns	E
$t_{EWLR}$	Control low pulse width (read)	60	-	-	ns	E
$t_{DS6}$	Data setup time	40	-	-	ns	D0~D7
$t_{DH6}$	Data hold time	10	-	-	ns	
$t_{ACC6}$	/RD access time	-	-	140	ns	D0~D7 CL = 100pF
$t_{OH6}$	Output disable time	5	-	50	ns	

## Serial Interface Timing

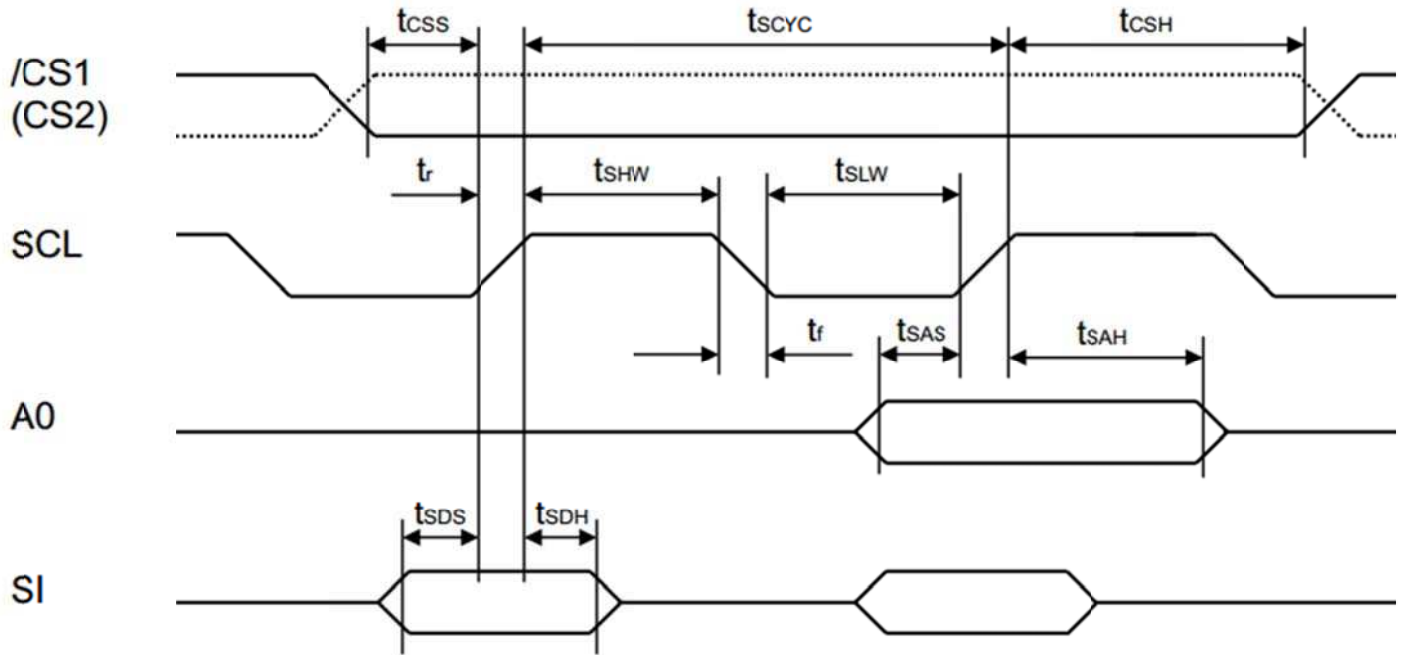

(VDD = 2.7 ~ 3.6V, Ta = -40 ~ +85°C)

Symbol	Parameter	Min.	Typ.	Max.	Unit	Condition
$t_{scyc}$	Serial clock cycle	120	-	-	ns	SCL
$t_{SHW}$	Serial clock H pulse width	60	-	-	ns	SCL
$t_{SLW}$	Serial clock L pulse width	60	-	-	ns	SCL
$t_{sAS}$	Address setup time	30	-	-	ns	A0
$t_{sAH}$	Address hold time	20	-	-	ns	A0
$t_{SDS}$	Data setup time	30	-	-	ns	SI
$t_{SDH}$	Data hold time	20	-	-	ns	SI
$t_{css}$	Chip select setup time	20	-	-	ns	/CS1, CS2
$t_{csH}$	Chip select hold time	40	-	-	ns	/CS1, CS2

## Example Initialization Program

```

/*****/
void data_out(unsigned char i) //Data Output 8-bit parallel Interface
{
    A0 = 1;                //Data register
    WR1 = 0;              //Write enable
    P1 = i;               //put data on port 1
    WR1 = 1;              //Clock in data
}
void comm_out(unsigned char i) //Command Output 8-bit parallel Interface
{
    A0 = 0;                //Instruction register
    WR1 = 0;              //Write enable
    P1 = i;               //put data on port 1
    WR1 = 1;              //Clock in data
}
/*****/
/*****/
*      Initialization For NT7534H      *
/*****/
void resetLCD()
{
    RES = 0;
    delay(100);
    RES = 1;
    delay(100);
}
void init_LCD()
{
    CS1 = 0;                //Chip Select
    CS2 = 1;                //Chip Select
    RD1 = 1;                //Read disable
    comm_out(0xA2);         //1/9 bias
    comm_out(0xA0);         //ADC select
    comm_out(0xC8);         //COM output reverse
    comm_out(0xA4);         //display all points normal
    comm_out(0x40);         //display start line set
    comm_out(0x25);         //internal resistor ratio
    comm_out(0x81);         //electronic volume mode set
    comm_out(0x18);         //electronic volume
    comm_out(0x2F);         //power controller set
    comm_out(0xAF);         //display on
}
/*****/

```

## Quality Information

Test Item	Content of Test	Test Condition	Note
High Temperature storage	Endurance test applying the high storage temperature for a long time.	+80°C , 200hrs	2
Low Temperature storage	Endurance test applying the low storage temperature for a long time.	-30°C , 200hrs	1,2
High Temperature Operation	Endurance test applying the electric stress (voltage & current) and the high thermal stress for a long time.	+70°C 200hrs	2
Low Temperature Operation	Endurance test applying the electric stress (voltage & current) and the low thermal stress for a long time.	-20°C , 200hrs	1,2
High Temperature / Humidity Operation	Endurance test applying the electric stress (voltage & current) and the high thermal with high humidity stress for a long time.	+60°C , 90% RH , 96hrs	1,2
Thermal Shock resistance	Endurance test applying the electric stress (voltage & current) during a cycle of low and high thermal stress.	-20°C,30min -> 25°C,5min -> 70°C,30min = 1 cycle 10 cycles	
Vibration test	Endurance test applying vibration to simulate transportation and use.	10-55Hz , 15mm amplitude. 60 sec in each of 3 directions X,Y,Z For 15 minutes	3
Static electricity test	Endurance test applying electric static discharge.	VS=800V, RS=1.5kΩ, CS=100pF One time	

**Note 1:** No condensation to be observed.

**Note 2:** Conducted after 4 hours of storage at 25°C, 0%RH.

**Note 3:** Test performed on product itself, not inside a container.

## Precautions for using LCDs/LCMs

See Precautions at [www.newhavendisplay.com/specs/precautions.pdf](http://www.newhavendisplay.com/specs/precautions.pdf)

## Warranty Information and Terms & Conditions

[http://www.newhavendisplay.com/index.php?main\\_page=terms](http://www.newhavendisplay.com/index.php?main_page=terms)