



Half Wave and Full Wave Vibrators

7

Range up to 3 mm and 2740 N

Product group

Types

W ZA Y ZA Y ZU

- According to VDE 0580 and ISO 9001 (conform with article 10 of direction 73/23/EEC – according to CENELEC memorandum no. 3 of march 1987).
- Full (W) and Half-wave (Y) vibrators provide oscillations at or twice the supply frequency (50 Hz supply = 50 or 100 Hz output) for application with user designed spring system.
- Encapsulated coil construction with separate armature
...ZA... high profile units – available in open construction
...ZU... low profile units – coils retained by encapsulation
- Class B coil insulation for voltages up to 415 V.
- Connections with free leads – extra long leads and special cables can be provided.
- Protection IP 00 according to DIN VDE 0470/EN 60529
- Amplitude control by thyristor, potentiometer or variable transformer is recommended.
- Thyristor controllers available for full and half-wave operation with option of local or remote input signal.
- Suitable for mounting in any attitude. Alternative fixing arrangements are available.
- Armatures with “shaded poles” available for W ZA W units preventing vibration for application as stroke solenoid or holding magnet.
- Modifications and special designs on request.
- General purpose vibrators for
Packing Mixing Conveying
Feeding Sorting Sieving
and similar applications

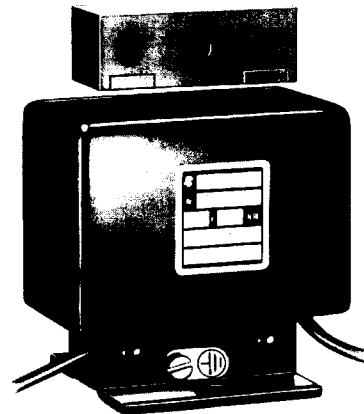

Fig. 1
Type W ZAW 060 X 00 A05



W	ZA W Full wave	010	040	060	080
(vibrations at twice supply frequency)					
	Air gap δ (static) (mm)	1	2	2,5	2,5
	Power consumption P_s (static) (VA)	15	45	103	205
	Magnetic force \bar{F} (static) (N)	13,7	18,6	42	118
	Armature weight m_A (kg)	0,026	0,07	0,17	0,31
	Magnet weight m_M (kg)	0,21	0,52	1,12	2,3
Y	ZA W Half wave	010	040	060	080
(vibrations at supply frequency)					
	Air gap δ (static) (mm)	1	2	2,5	2,5
	Power consumption P_s (static) (VA)	15,5	40	76	180
	Magnetic force \bar{F} (static) (N)	32	36	65	176
	Armature weight m_A (kg)	0,026	0,07	0,17	0,31
	Magnet weight m_M (kg)	0,21	0,52	1,12	2,3
Y	ZU W Half wave	080	090	120	130
(vibrations at supply frequency)					
	Air gap δ (static) (mm)	2,5	3	3	3
	Power consumption P_s (static) (VA)	250	425	1200	2060
	Magnetic force \bar{F} (static) (N)	314	510	1450	2740
	Armature weight m_A (kg)	0,3	0,6	1,3	2,6
	Magnet weight m_M (kg)	2	3,2	7,6	13,5

PERFORMANCE TABLE

terms are explained in Technical Bulletin Y XX & VDE 0580 (including calculation formula for system dynamic performance).

SUPPLY VOLTAGE – standard A.C. 24 V, 110 V 220 V, 240 V/50 Hz.

(Sizes 010 to 080 – 240 V max. Sizes 090 to 130 – 415 V max.)

60 Hz – Special coil winding is required to maintain 50 Hz static performance

and an increase in vibrator size may be necessary to provide the increased force required for dynamic function

TABLE BASIS – Tolerance $\pm 10\%$ (inherent & manufacture)

220 V 50 Hz 100 %

Ambient temperature 35° C

Heat insulated base

Silicon rectifier

Free air mounted

Static – not-vibrating

STATIC AIR GAP (δ) Armature and field frame clearance in non-vibrating condition.

POWER CONSUMPTION (P_s) – Static power at rated voltage, frequency, static air gap (δ) and coil temperature 20° C.

MAGNETIC FORCE (\bar{F}) – Maximum with static air gap (δ), 95% rated voltage, HOT condition, measured with D.C. voltage of A.C. half-wave peak value ($\bar{F} = 2 \times$ Amplitude force F_A).

HOT CONDITION – Final temperature attained, not-vibrating, rated voltage and frequency, 35° C ambient temperature and static air gap (δ).

DUTY RATING – Continuous dynamic duty at rated voltage, frequency and air gap. Special coils are provided for varying duty, frequency, air gap and application.

INSTALLATION – Rigid mounting and parallel armature and vibrator faces are essential to avoid secondary oscillations. Vibrator force must align with the system gravity centre. Spring system design and tuning, amplitude control and dynamic air gap determine vibrator performance to be within thermal design and coil winding. The armature must not be allowed to contact the pole faces, by adjustment of the load, amplitude and air gap.

CONTROLLERS Full or half-wave thyristor units (2/6/11/15 amp. – 110/240 V with current (0 – 20 mA), voltage (0 – 10 V) or manual potentiometer input for output adjustment are available and incorporate rectification for half-wave application.

SPECIAL

Special vibrators, armatures and mounting arrangements can be provided to meet specific, quantity applications.

...ZA... (high profile) units are available in open construction. Encapsulation by user is recommended

...ZU... (low profile) units can only supplied in encapsulated form as this retains the coil.

Special coil windings are supplied for various voltages, frequencies, duty ratings and air gaps. Larger air gaps will necessitate a decrease in force, whereas the forces may be increased for smaller air gaps than listed in the tables.

The low profile, high force, vibrators (...ZU...) are available for full wave application, but the resultant dynamic air gaps are not practical above sizes 080/090.

Conversion Factors

1 N = 0.102 kp \approx 0.1 kg
 1 kg = 2.2 lb.
 1 mm = 0.039 in.
 1 Ncm = 0.086 in. lb.

Dimension tables for vibrators W ZA W, Y ZA W and Y ZU W

W ZA W, Y ZA W

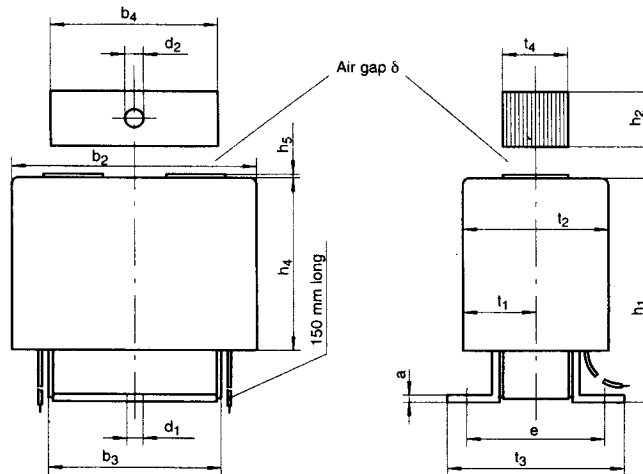

Fig. 2: Encapsulated construction
Type W ZA W 010 to 080 X00 A05
Y ZA W 010 to 080 X 00 A05

Type	W ZA W and Y ZA W														
Dim.	Dimensions (mm)														
	a	b ₂	b ₃	b ₄	d ₁	d ₂	e	h ₁	h ₂	h ₄	h ₅	t ₂	t ₃	t ₄	t ₅
Size 010	2	44	31,2	30	3,2	4,1	30	41,8	10	32	–	26	42	12	–
040	2	66	46,5	45	4,3	5,1	37	60,8	15	46,5	0,5	39	47,5	17,5	–
060	3	78	55,2	54	6,4	6,1	46	75,8	20	56,5	0,5	48	61,5	21,5	22
080	3	92	68,2	66	6,4	6,1	67	90,8	22	69	1	62	83	33	28,5

Y ZU W

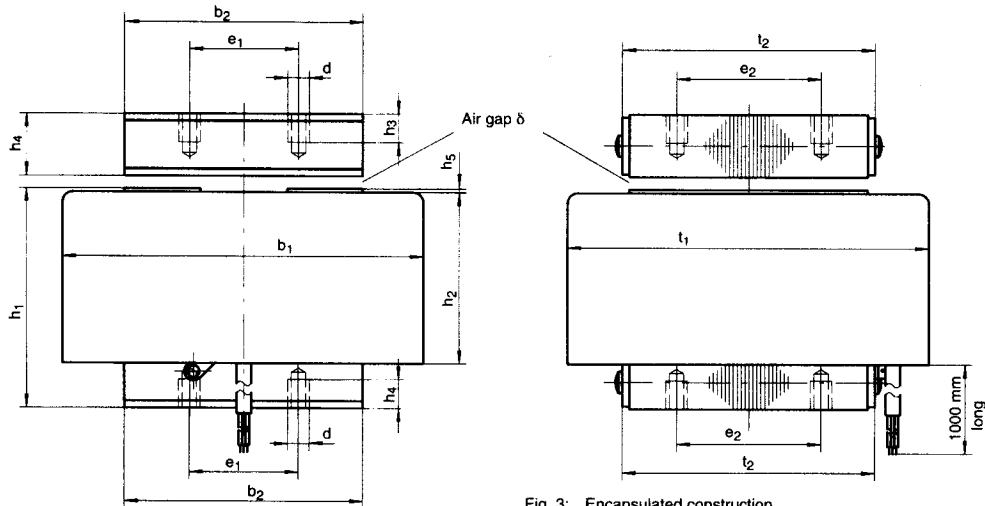

Fig. 3: Encapsulated construction
Type Y ZU W 080 to 130 X00 A01

Type	Y ZU W											
Dim.	Dimensions (mm)											
	b ₁	b ₂	d	e ₁	e ₂	h ₁	h ₂	h ₃	h ₄	h ₅	t ₁	t ₂
Size 080	100	66	M6	30	1)	61,5	48	9	17,5	1	68	38
090	100	66	M6	30	40	61,5	48	9	17,5	1	100	70
120	155	108	M10	50	1)	90,5	66	15	26,5	1	110	68
130	155	108	M10	50	80	90,5	66	15	26,5	1	168	126

Note 1) = e₂ two tapped holes on centre line. Size 080 and 120.

Conversion Factors

1 N = 0.102 kp ≈ 0.1 kg
1 kg = 2.2 lb.
1 mm = 0.039 in.
1 Ncm = 0.086 in. lb.



Classification for vibrators W ZA W, Y ZA W and Y ZU W

Classification

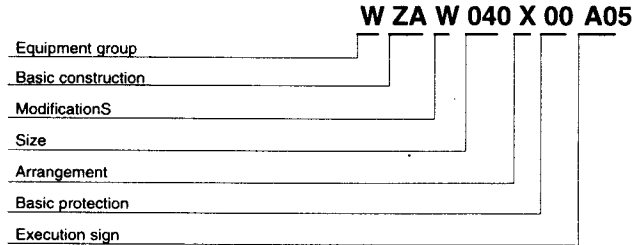

Order example

- | | | | |
|--------------------|----------------------------------|--------|-------|
| I. Equipment group | - Full wave A.C. supply | - W | - W |
| | - Half wave A.C. supply | - Y | |
| Basic construction | - High profile | - ZA | - ZA |
| | - Low profile | - ZU | |
| Modification | - Standard design | | - W |
| Size | - Select from tables | | - 040 |
| Arrangement | - Standard X | | - X |
| Basic protection | - IP 00 | | - 00 |
| Execution sign | - W ZA encapsulated construction | - A 05 | - A05 |
| | - Y ZA encapsulated construction | - A05 | |
| | - Y ZU encapsulated construction | - A01 | |
-
- | | |
|--|-------|
| II. State – Voltage V – Standards – page 2 | 220 V |
| Frequency (Hz) | 50 Hz |
| Duty rating – standard | 100 % |
| Static air gap (δ) – Standards – page 2 | 2 mm |
-
- III. Additional requirements, specify: –
1. Special protection – Tropical
 2. Extra long leads
 3. Armature is included – state if NOT required.
 4. Controllers – see page 2

Subject to our standard conditions.