

# CONTA ELECTRONICS

## RELAYS

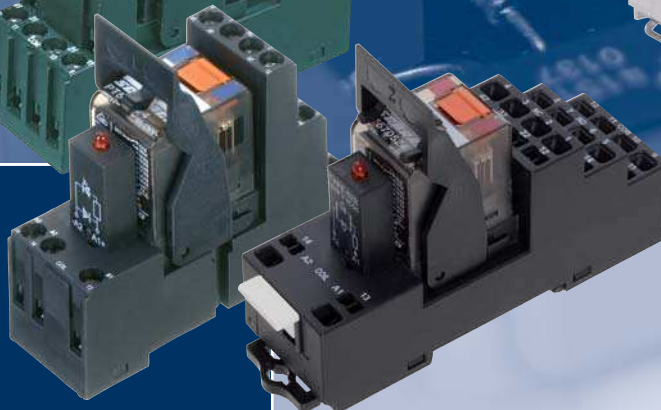
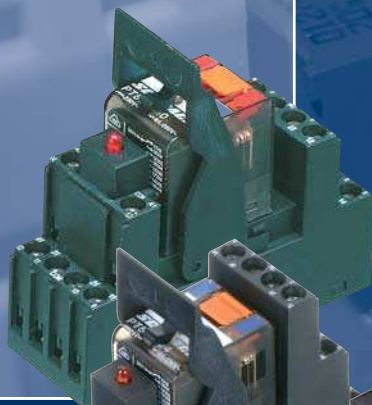
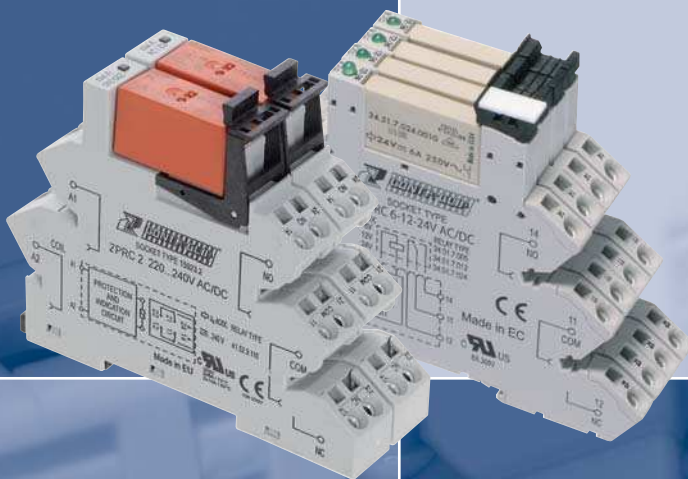

# Relay

## Overview

Overview	2
The Company	3
<b>Relay technology - introduction</b>	4
<b>Compact plug relays PRC</b>	6
Relay terminals with 1 CO relay   Screw or tension-spring connections	8
Relay terminals with 2 CO relays   Screw or tension-spring connections	12
<b>Plug relay system PRS</b> Screw connections	16
Relay 1-CO <b>PRS 1 XT</b>   Screw connection	18
Relay 2-CO <b>PRS 2 XT</b>   Screw connection	20
Relay 1-CO <b>PRS 1</b>   Screw connection	22
Relay 2-CO <b>PRS 2</b>   Screw connection	24
Relay 2-CO <b>PRS 2 G</b>   Screw connection	26
Relay 4-CO <b>PRS 4</b>   Screw connection	28
Relay 4-CO <b>PRS 4 G</b>   Screw connection	30
Relay 4-CO <b>PRS 4 eco</b>   Screw or tension-spring connection	32
<b>Plug relay system PRS</b> Tension-spring connection	34
Relay 1-CO <b>PRS 1 XT</b>   Tension-spring connection	36
Relay 2-CO <b>PRS 2 XT</b>   Tension-spring connection	37
Relay 1-CO <b>PRS 1 Z</b>   Tension-spring connection	38
Relay 2-CO <b>PRS 2 Z</b>   Tension-spring connection	40
Relay 4-CO <b>PRS 4 Z</b>   Tension-spring connection	42
<b>Auto-Off-On-Relay RM/HA/24 VUC</b>	44
<b>Opto-coupler  Solid-State</b>	46
<b>Plug-Solid-State-Compact PSC</b>	48
Solid-state terminals   Screw or tension-spring connections	50
<b>Solid-state relay modules CMS-SSR</b>	52
<b>Functional relays</b>	54
Multi-function timing relay terminal <b>MFR-PRC</b>   Screw connection	58
Multi-function timing relay terminal <b>MFR-PRC</b>   Screw connection	61
Multi-function timing relay <b>MFR 1</b>   <b>MFR 4</b>   <b>MFR 5</b>   Screw connection	62
Clock-pulse generator dual-time relays <b>MFR 6</b>   Screw connection	64
Stairway timed light switch <b>TSR 1</b>   <b>TSR 2</b>   Screw connection	66
Under voltage monitoring relays <b>USR 1</b>   <b>USR 2</b>   Screw connection	68
Star-delta switching relays <b>SDSR 1</b>   <b>SDSR 2</b>   Screw connection	70
Voltage monitoring relays <b>VMR1</b>   <b>VMR 2</b>   Screw connection	72
Voltage-monitoring relay <b>VMR 3</b>   Screw connection	74

## CONTA-CLIP

### The Company

Founded and kept in the family since 1977: **CONTA-CLIP** is an owner-operated company that is a mid-sized global player. Users of electrical and electronic connection products have come to trust us for our reliable components. They also trust in our wide-reaching competence within the market and industry which has evolved over many years. In the years since our company was founded, we have evolved from a manufacturer to an innovator.

Our employees are connectivity specialists coming from a wide variety of backgrounds. They understand the specific problems, requirements and challenges of our customers. This ensures communication among equals. We then invest our gains directly into maintaining a modern and efficient production process. This allows us to maintain the most modern machinery at our facilities. We develop and produce the tooling ourselves. We neither make nor accept any compromise in the quality of materials used in our products.

Our top-class products are supported by this interplay between top-class men and machinery. We have also designed our range of services to align with customer needs. We develop electronics, assemble terminal rails, take care of component labelling, and deliver completely populated housings when needed – totally customized and expedited.

Our passion and concern for our customers' challenges does not end after we've delivered our solution. **CONTA-CLIP** customer representatives are always ready to offer their support to the customer, because service and support are our top priorities.

You can find out all about product innovations, trade fair appointments, press releases, and more at our official **CONTA-CLIP** web site.

If you want to make sure you do not miss any news, subscribe with no obligation to our **CONTA-CLIP** newsletter by e-mail.

[www.conta-clip.com](http://www.conta-clip.com)



## Relay Systems

Relay technology continues to play a large role in the reliability of industrial control and automation solutions. Because of their thin design, relay couplers find use in rail-oriented control designs. Thanks to their features, **CONTA-CLIP** relay couplers are well-suited for use in secure electrical isolation of circuits or for the multiplication of contacts.

Whether it is in manufacturing, electrical machine and plant instrumentation, control engineering, building automation, or process engineering – everywhere it is important to guarantee that the signal exchange between the peripheral devices and the upper-level central control and instrumentation systems remains potential-free and operationally safe.

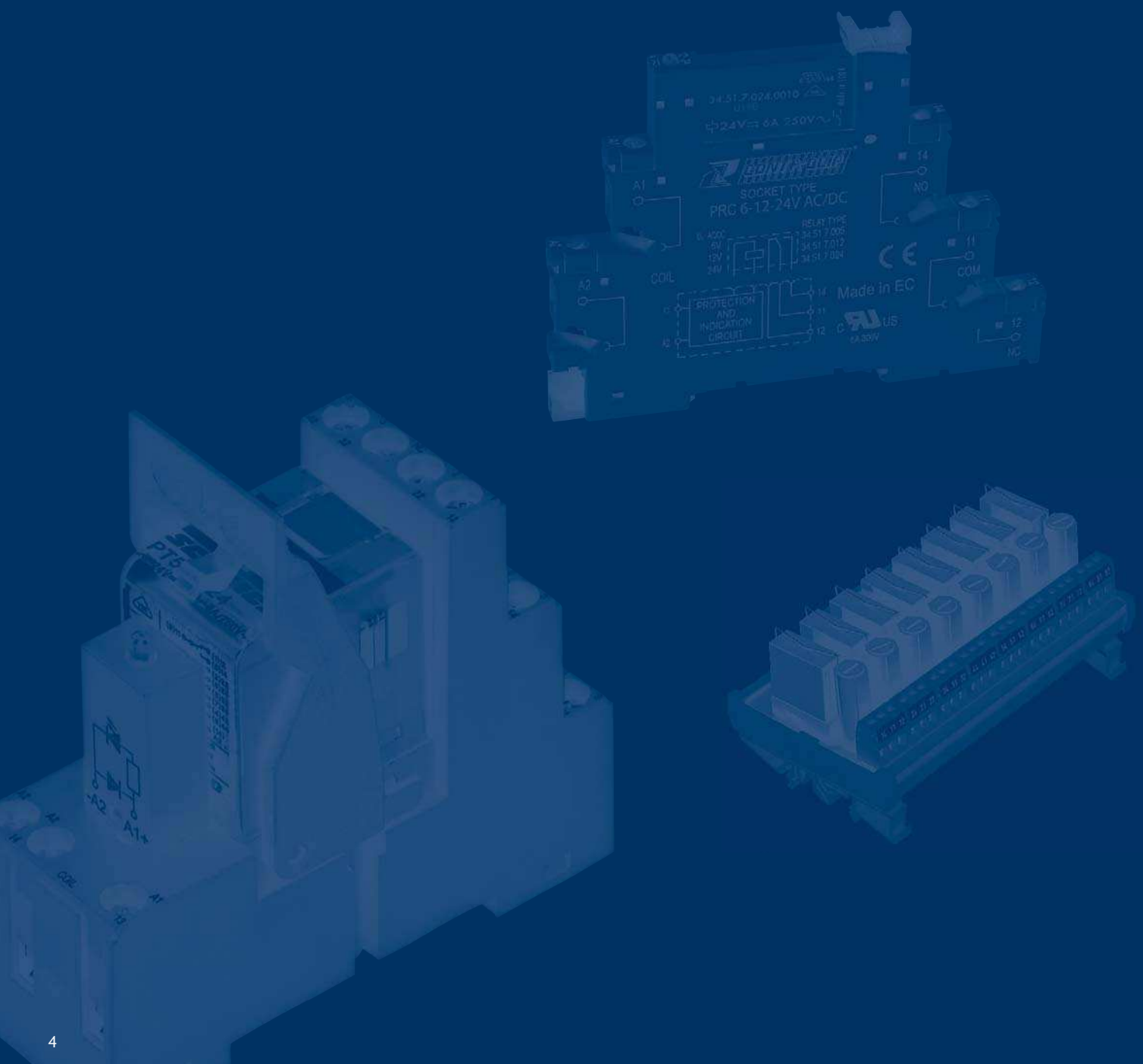

## Relay Systems



### Compact plug relays PRC

**PRC** relay couplers distinguish themselves by their compact shape in the terminal block design. With a width of just 6.2 mm for a 1 CO relay and 14 mm for a relay with 2 COs, there are many application possibilities. The basis relay offers 28 versions, including screw and tension-spring connections, and available coil voltages from 6 to 24 VDC and from 12 to 240 VAC/DC. With the **AQI** cross-connection system, mutual potentials can be carried out over the coil or contact sides. For excellent equipment identification, the socket base has a labelling surface for the standard **PMC** marking system. **CONTA-CLIP** also offers a customer-specific labelling service, in addition to the standard marking.

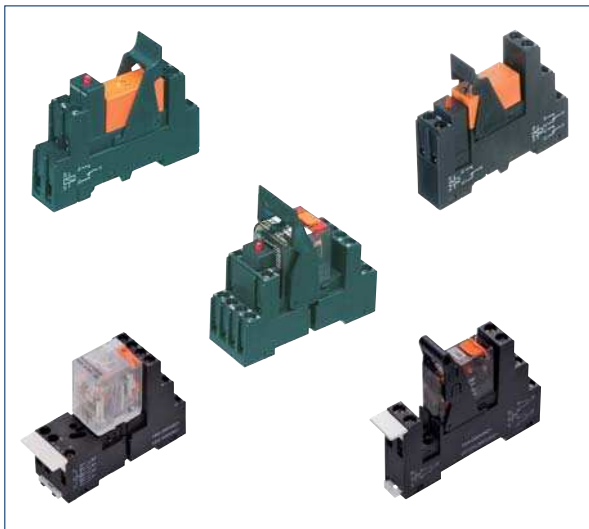

### Plug relay system PRS

PRS relay couplers are available in one-, two- and four-change-over design. The relay plug-in modules are designed for a measured voltage from 300 V. They can be combined with relays (in the coil-voltage range of 12 to 220 VDC and 12 to 230 VAC) and the appropriate insert-modules or status displays. In order to guarantee that the relay is mechanically snug in the frame, a relay holding-clamp can be mounted. The switchable continuous current is 12 amps for the one- and two-CO versions, and 6 amps for the four-CO versions. The **PRS...G** types have electrical contacts which are designed so that the coil side and the contact side are arranged separately from another. The relay frame, relay insert module and holding-clamp can be modularly assembled and combined.



### RM/HA/24 VUC | AUTO-ON-OFF-relay

This compact relay component acts as the interface between the encoder, input, control signals and the control or factory-level. It also enables simple switching from automatic mode to OFF or manual mode. Because of the coil construction for the 24 V AC/DC input, the component has a wide variety of uses. A potential-free check-back contact for control allows for convenient monitoring of the operating status. The status is also shown with an integrated LED. The integrated relay is designed with a switching capacity of up to 2500 VA at a rated voltage of 250 V.

## Compact plug relays PRC

### Relay terminals with 1-CO relay

#### 1. Overview

**a Labelling | Marking**  
The socket bases have a labelling surface which is optimally suited for our **PMC Pocket-Maxicard (PMC BSTR 6/30)** standard marking systems. In addition to our large variety of standard labels, **CONTA-CLIP** can also provide "just-in-time" individual labelling for you.



**b Using the mount/dismount lever**  
The mounting and dismounting mechanism forms a reliable connection by latching the relay with the socket base. The fitted relay can be removed, easily and without force, from the socket base by using the dismount function of the lever!



**d Pluggable external cross-connections**

The AQI/PRC pluggable cross-connection system enables a time-saving distribution of potentials. The AQI/PRC is constructed so that it is protected against accidental touch. It is available as a 20-pole unit, in either yellow, blue or black. The cross-connector can be shortened to fewer poles in order to fit the required interface. Insulation plating can be used to insulate the ends.



**c Pluggable relays**  
Pluggable relays are also available with AgSNO and gold contacts, to fit with the many functions of your individual requirements!

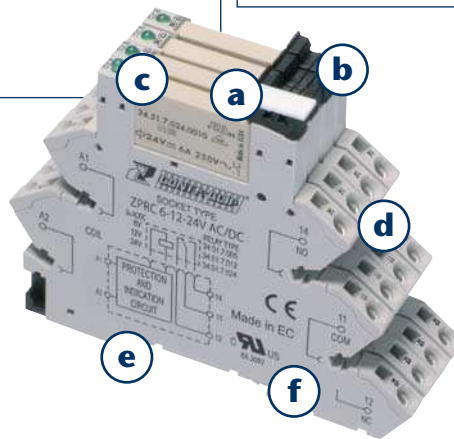

**e Mounts on standard TS 35 rail**  
**CONTA-CLIP** relay terminal can be flexibly mounted on standard TS 35 mounting rails according to EN 50035 and EN 50022.

**f Connection types**  
All of our relay terminals are optionally available with screw or tension-spring connection systems.

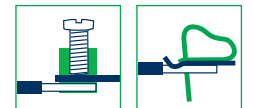

#### 2. Approvals (Details upon request.)



#### 3. Features

##### 1. Relay

- 5 mm width, extremely narrow monitoring relay
- Sensitive DC coil, 170 mW
- Secure isolation between the coil and the contacts, according to VDE 0160/EN 50178
- 6 mm clearance distance, 8 mm creepage distance
- 6 kV (1.2/50 μs)
- Protection class II, according to VDE 0631/EN 60730

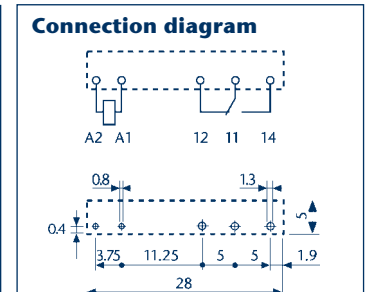
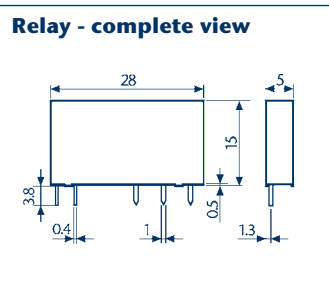

# Compact plug relays PRC

## Relay terminals with 1-CO relay

### II. Socket base

- Mount on TS 35
- Very flexible and modular construction of individual relay bases
- User-friendly, because the relays can be easily replaced
- High-quality connecting terminals (tension-spring or screw connection system)
- Integrated EMC coil circuitry, and LED
- High-quality innovative mount/dismount lever
- All versions are optionally available with screw or tension-spring connection system

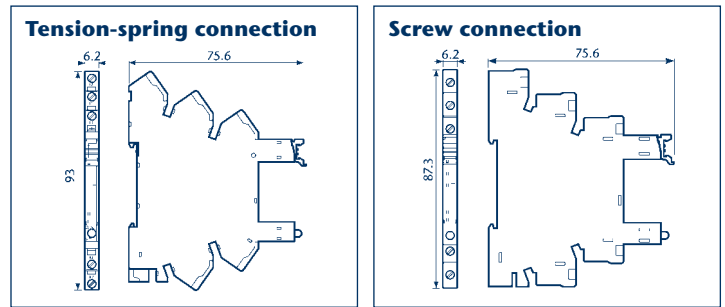

### 4. Specifications

#### Electro-mechanical relay

##### Insulation properties

Insulation coordination, according to EN 61810-1, VDE 0435 T 201.	Rated insulation voltage of V	250
	Rated surge voltage kV	4
	Pollution degree	3
	Overtoltage category	III

##### EMC - interference immunity of the control circuit (coil)

BURST (5... 50) ns, 5 kHz, on A 1 - A 2	EN 61000-4-4	class 4 (4 kV)
SURGE (1.2/50) μs on A 1 - A 2 (differential mode)	EN 61000-4-5	class 3 (2 kV)

##### Additional data

Bounce time by closure of the NO/NC	ms	1/6
Resistance to vibration (10... 55 Hz, max ± 1 mm):		
	NO/NC g/g	10/5 flux density
Ambient heat dissipation	without contact current W	0.2 (12 V) - 0.9 (240 V)
	by continuous current W	0.5 (12 V) - 1.5 (240 V)

### 5. Contact data

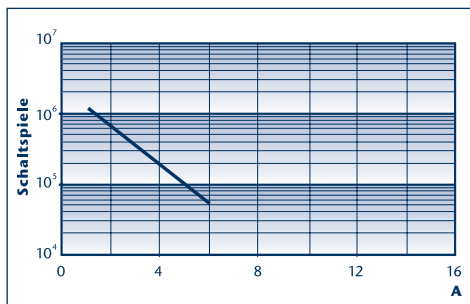

Service life of contact under AC 1 load

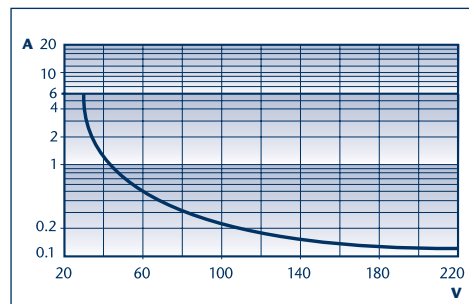

Switching capacity under DC 1 load

- Under resistive load (DC 1) and with an intersection of current and voltage that lies under the curve: this is an indication of an electrical life span greater to or equal to 100,000 switching cycles.
- Under an inductive load (DC 13), a free-wheel diode must be switched parallel to the load. Note: the return time is increased.

### 6. Coil data

#### DC version

Rated voltage	Operating Range		Resistance R Ω	Rated current I mA
	U <sub>N</sub> V	U <sub>min</sub> V / U <sub>max</sub> V		
5	3.5	7.5	130	38.4
12	8.4	18	840	14.2
24	16.8	36	3.350	7.1
48	33.6	72	12.300	3.9
60	42	90	19.700	3

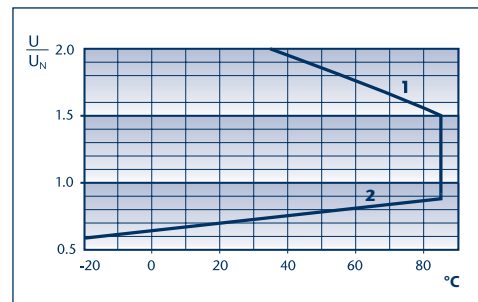

Reliable range of operating voltage

- 1 Max. permitted coil voltage
- 2 Response voltage, when coil temperature equal to ambient temperature

## Compact plug relays PRC

### Screw-connection relay terminals

- Consisting of: basic terminal and pluggable relay.
- Mount on TS 35

### Connection diagram

- Internal EMC coil circuitry and LED display
- LW versions: an internal AC residual-current suppression and LED display

#### PRCU 1/6V DC

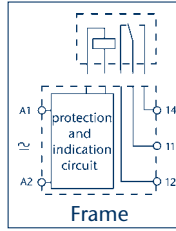

#### PRCU 1/12V DC

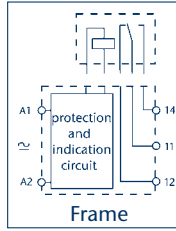
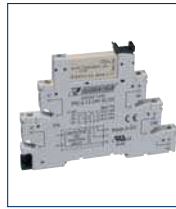

#### PRCU 1/24V DC

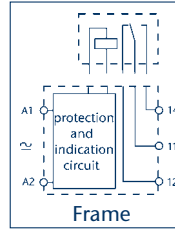
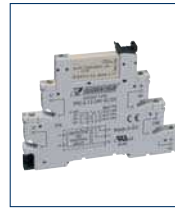

#### PRCU 1/12V AC/DC

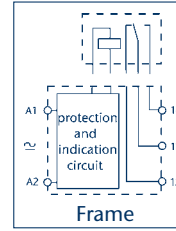
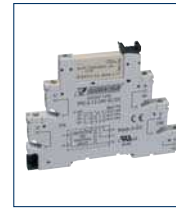

#### PRCU 1/24V AC/DC

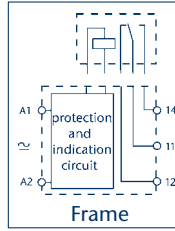
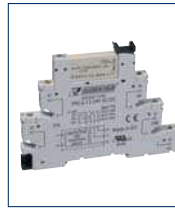

Type	PRCU 1/6 V DC	PRCU 1/12 V DC	PRCU 1/24 V DC	PRCU 1/12 V AC/DC	PRCU 1/24 V AC/DC
<b>Cat. no./Qty.</b> Type/Colour grey (RAL 7032)	<b>15513.2/10</b>	<b>15514.2/10</b>	<b>15515.2/10</b>	<b>15569.2/10</b>	<b>15508.2/10</b>
Size (L x W x H) with TS 35 x 7.5	87.3 x 6.2 x 79.9 mm	87.3 x 6.2 x 79.9 mm	87.3 x 6.2 x 79.9 mm	87.3 x 6.2 x 79.9 mm	87.3 x 6.2 x 79.9 mm
Weight	36 g	36 g	36 g	36 g	36 g
Rated operating voltage	6 V DC	12 V DC	24 V DC	2 V AC/DC	24 V AC/DC
<b>General information</b>					
Mech. life span AC/DC switching cycles	-/10 x 10 <sup>6</sup>	-/10 x 10 <sup>6</sup>	-/10 x 10 <sup>6</sup>	10 x 10 <sup>6</sup> /10 x 10 <sup>6</sup>	10 x 10 <sup>6</sup> /10 x 10 <sup>6</sup>
Electrical life span AC 1 switching cycles	60 x 10 <sup>3</sup>	60 x 10 <sup>3</sup>	60 x 10 <sup>3</sup>	60 x 10 <sup>3</sup>	60 x 10 <sup>3</sup>
Response time/release time	5/6 ms	5/6 ms	5/6 ms	5/6 ms	5/6 ms
Insulation coordination, EN 61810-5	4 kV/3	4 kV/3	4 kV/3	4 kV/3	4 kV/3
Dielectric strength coil/contacts (1.2/50 μs)	6 kV	6 kV	6 kV	6 kV	6 kV
Dielectric strength of open contacts	1,000 V AC	1,000 V AC	1,000 V AC	1,000 V AC	1,000 V AC
Ambient temperature	-40 to +70°C	-40 to +70°C	-40 to +70°C	-40 to +70°C	-40 to +70°C
Relay protection type	RT II	RT II	RT II	RT II	RT II
<b>Ratings for socket base</b>					
Ambient temperature	-40 to +70°C	-40 to +70°C	-40 to +70°C	-40 to +70°C	-40 to +70°C
Insulation stripping length	10 mm	10 mm	10 mm	10 mm	10 mm
Max. connection cross-section, solid   flexible	1x2.5   1x2.5 mm <sup>2</sup> 1x14   1x14 AWG	1x2.5   1x2.5 mm <sup>2</sup> 1x14   1x14 AWG	1x2.5   1x2.5 mm <sup>2</sup> 1x14   1x14 AWG	1x2.5   1x2.5 mm <sup>2</sup> 1x14   1x14 AWG	1x2.5   1x2.5 mm <sup>2</sup> 1x14   1x14 AWG
<b>Ratings for plug-relays combined with socket base</b>					
<b>Contacts</b>					
Number of contacts	1 CO contact	1 CO contact	1 CO contact	1 CO contact	1 CO contact
Max. continuous current   Max. inrush current	6/10 A	6/10 A	6/10 A	6/10 A	6/10 A
Rated voltage   Max. switching voltage	250/400 VAC*	250/400 VAC*	250/400 VAC*	250/400 VAC*	250/400 VAC*
Max. power rating AC 1	1,500 VA	1,500 VA	1,500 VA	1,500 VA	1,500 VA
Max. power rating AC 15 (230 V AC)	300 VA	300 VA	300 VA	300 VA	300 VA
1-phase motor load, AC 3 operation (230 V AC)	0.185 kw	0.185 kw	0.185 kw	0.185 kw	0.185 kw
Max. switching current DC 1:30/110/220 V	6/0.2/0.12 A	6/0.2/0.12 A	6/0.2/0.12 A	6/0.2/0.12 A	6/0.2/0.12 A
Min. switching load	300 (5/5) mW (V/mA)	300 (5/5) mW (V/mA)	300 (5/5) mW (V/mA)	300 (5/5) mW (V/mA)	300 (5/5) mW (V/mA)
Standard contact material	AqNi	AqNi	AqNi	AqNi	AqNi
<b>Coil</b>					
Rated voltage (U <sub>N</sub> )	5 V DC   - AC	12 V DC   - AC	24 V DC   - AC	12 V DC   12 AC	24 V DC   24 AC
Power rating AC/DC	0.2 W	0.2 W	0.2 W	0.2 W	0.2 W
Operating range	-	-	-	(0.8 to 1.1) U <sub>N</sub> AC (50/60 Hz) (0.8 to 1.2) U <sub>N</sub> DC	(0.8 to 1.1) U <sub>N</sub> AC (50/60 Hz) (0.8 to 1.2) U <sub>N</sub> DC
Holding current	0.6 U <sub>N</sub> DC	0.6 U <sub>N</sub> DC	0.6 U <sub>N</sub> DC	0.6 U <sub>N</sub> AC/0.6 U <sub>N</sub> DC	0.6 U <sub>N</sub> AC/0.6 U <sub>N</sub> DC
Drop-out voltage	0.05 U <sub>N</sub> DC	0.05 U <sub>N</sub> DC	0.05 U <sub>N</sub> DC	0.1 U <sub>N</sub> AC/0.05 U <sub>N</sub> DC	0.1 U <sub>N</sub> AC/0.05 U <sub>N</sub> DC

### Individual components, socket base

Type/Colour grey (RAL 7032)	PRC 6-12-24V DC	PRC 6-12-24V DC	PRC 6-12-24V DC	PRC 6-12-24V AC/DC	PRC 6-12-24V AC/DC
<b>Cat. no./Qty.</b>	<b>15490.2/10</b>	<b>15490.2/10</b>	<b>15490.2/10</b>	<b>15488.2/10</b>	<b>15488.2/10</b>

### Individual components, plug relays

Type/Rated voltage	PRC 1/5V DC	PRC 1/12V DC	PRC 1/24V DC	PRC 1/12V DC	PRC 1/24V DC
<b>Cat. no./Qty.</b>	<b>15500.2/10*3</b>	<b>15501.2/10*3</b>	<b>15502.2/10*3</b>	<b>15501.2/10*3</b>	<b>15502.2/10*3</b>

Accessories AQI/PRC external insulated cross-connector	AQI/PRC/20	AQI/PRC/20	AQI/PRC/20	AQI/PRC/20	AQI/PRC/20
<b>Cat. no./Qty.</b> yellow	<b>15545.8/1</b>	<b>15545.8/1</b>	<b>15545.8/1</b>	<b>15545.8/1</b>	<b>15545.8/1</b>
<b>Cat. no./Qty.</b> blue	<b>15545.5/1</b>	<b>15545.5/1</b>	<b>15545.5/1</b>	<b>15545.5/1</b>	<b>15545.5/1</b>
<b>Cat. no./Qty.</b> black	<b>15545.4/1</b>	<b>15545.4/1</b>	<b>15545.4/1</b>	<b>15545.4/1</b>	<b>15545.4/1</b>

TW/PRC partitions	TW/PRC	TW/PRC	TW/PRC	TW/PRC	TW/PRC
<b>Cat. no./Qty.</b>	<b>15546.2/1</b>	<b>15546.2/1</b>	<b>15546.2/1</b>	<b>15546.2/1</b>	<b>15546.2/1</b>

PMC labelling/markers	PMC BSTR 6/30	PMC BSTR 6/30	PMC BSTR 6/30	PMC BSTR 6/30	PMC BSTR 6/30
<b>Cat. no./Qty.</b> , standard print, see catalog	CONTA-CONNECT	CONTA-CONNECT	CONTA-CONNECT	CONTA-CONNECT	CONTA-CONNECT
<b>Cat. no./Qty.</b> neutral	<b>9106.7/300</b>	<b>9106.7/300</b>	<b>9106.7/300</b>	<b>9106.7/300</b>	<b>9106.7/300</b>
<b>Cat. no./Qty.</b> , special print	<b>9107.7/300</b>	<b>9107.7/300</b>	<b>9107.7/300</b>	<b>9107.7/300</b>	<b>9107.7/300</b>

SDB screwdriver	SDB 0.6 x 3.5	SDB 0.6 x 3.5	SDB 0.6 x 3.5	SDB 0.6 x 3.5	SDB 0.6 x 3.5
<b>Cat. no./Qty.</b>	<b>1086.0/1</b>	<b>1086.0/1</b>	<b>1086.0/1</b>	<b>1086.0/1</b>	<b>1086.0/1</b>

\* The conditions of pollution degree 2 are fulfilled at 400 V.  
 \*1 In order for the relay to de-energise, the residual current can be suppressed/controlled via the SPS-230 V semiconductor outputs, longe control lines (LW), thyristors, and inductive proximity switch!  
 \*2 Since this relay is only produced for DC at a max. 60 V, the adjustment to the operating voltage occurs via the internal resistance and bridge rectifiers!  
 \*3 Relay available with gold contact, upon request!

**PRCU 1/48V AC/DC    PRCU 1/60V AC/DC    PRCU 1/125V AC/DC    PRCU 1/240V AC/DC    PRCU LW 1/125V AC/DC    PRCU LW 1/240V AC**

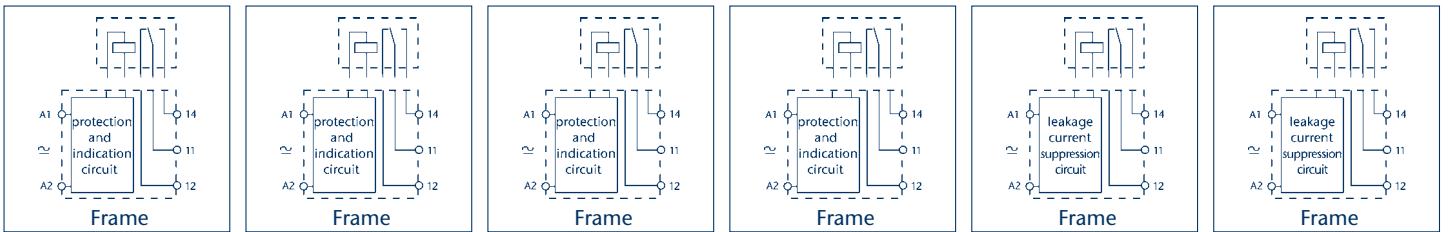
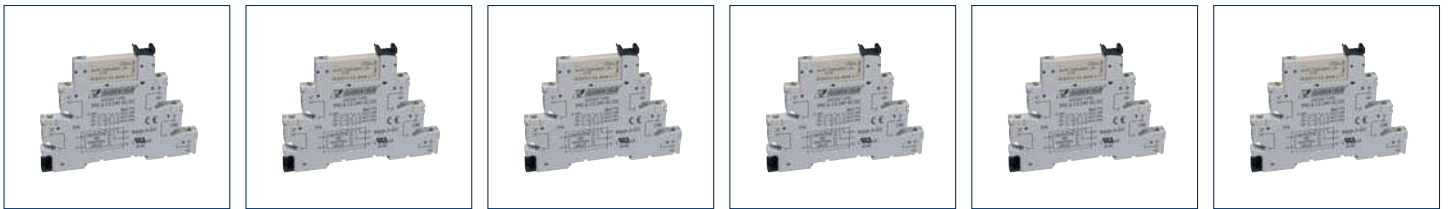

<b>PRCU 1/48 V AC/DC</b> <b>15509.2/10</b>	<b>PRCU 1/60 V AC/DC</b> <b>15510.2/10</b>	<b>PRCU 1/125 V AC/DC</b> <b>15511.2/10*2</b>	<b>PRCU 1/240 V AC/DC</b> <b>15512.2/10*2</b>	<b>PRCU LW 1/125 V AC/DC</b> <b>15553.2/10*2</b>	<b>PRCU LW 1/240 V AC</b> <b>15554.2/10*2</b>
87.3 x 6.2 x 79.9 mm	87.3 x 6.2 x 79.9 mm	87.3 x 6.2 x 79.9 mm	87.3 x 6.2 x 79.9 mm	87.3 x 6.2 x 79.9 mm	87.3 x 6.2 x 79.9 mm
36 g	36 g	36 g	36 g	36 g	36 g
48 V AC/DC	60 V AC/DC	125 V AC/DC	230 V AC/DC	125 V AC/DC	230 V AC/
10 x 10 <sup>6</sup> /10 x 10 <sup>6</sup>	10 x 10 <sup>6</sup> /10 x 10 <sup>6</sup>	10 x 10 <sup>6</sup> /10 x 10 <sup>6</sup>	10 x 10 <sup>6</sup> /10 x 10 <sup>6</sup>	10 x 10 <sup>6</sup> /10 x 10 <sup>6</sup>	10 x 10 <sup>6</sup> /10 x 10 <sup>6</sup>
60 x 10 <sup>3</sup>	60 x 10 <sup>3</sup>	60 x 10 <sup>3</sup>	60 x 10 <sup>3</sup>	60 x 10 <sup>3</sup>	60 x 10 <sup>3</sup>
5/6 ms	5/6 ms	5/6 ms	5/6 ms	5/6 ms	5/6 ms
4 kV/3	4 kV/3	4 kV/3	4 kV/3	4 kV/3	4 kV/3
6 kV	6 kV	6 kV	6 kV	6 kV	6 kV
1,000 V AC	1,000 V AC	1,000 V AC	1,000 V AC	1,000 V AC	1,000 V AC
-40 to +70°C	-40 to +70°C	-40 to +70°C	-40 to +70°C	-40 to +70°C	-40 to +70°C
RT II	RT II	RT II	RT II	RT II	RT II
-40 to +70°C	-40 to +70°C	-40 to +70°C	-40 to +70°C	-40 to +70°C	-40 to +70°C
10 mm	10 mm	10 mm	10 mm	10 mm	10 mm
1x2.5   1x2.5 mm <sup>2</sup>	1x2.5   1x2.5 mm <sup>2</sup>	1x2.5   1x2.5 mm <sup>2</sup>	1x2.5   1x2.5 mm <sup>2</sup>	1x2.5   1x2.5 mm <sup>2</sup>	1x2.5   1x2.5 mm <sup>2</sup>
1x14   1x14 AWG	1x14   1x14 AWG	1x14   1x14 AWG	1x14   1x14 AWG	1x14   1x14 AWG	1x14   1x14 AWG
1 CO contact	1 CO contact	1 CO contact	1 CO contact	1 CO contact	1 CO contact
6/10 A	6/10 A	6/10 A	6/10 A	6/10 A	6/10 A
250/400 VAC*	250/400 VAC*	250/400 VAC*	250/400 VAC*	250/400 VAC*	250/400 VAC*
1,500 VA	1,500 VA	1,500 VA	1,500 VA	1,500 VA	1,500 VA
300 VA	300 VA	300 VA	300 VA	300 VA	300 VA
0.185 kw	0.185 kw	0.185 kw	0.185 kw	0.185 kw	0.185 kw
6/0.2/0.12 A	6/0.2/0.12 A	6/0.2/0.12 A	6/0.2/0.12 A	6/0.2/0.12 A	6/0.2/0.12 A
300 (5/5) mW (V/mA)	300 (5/5) mW (V/mA)	300 (5/5) mW (V/mA)	300 (5/5) mW (V/mA)	300 (5/5) mW (V/mA)	300 (5/5) mW (V/mA)
AqNi	AqNi	AqNi	AqNi	AqNi	AqNi
48 V DC   48 AC	60 V DC   60 AC	110 to 125 V DC   110 to 125 AC	220 to 240 V DC   220 to 240 AC	110 to 125 V DC   110 to 125 AC	- V DC   220 to 240 AC
0.2 W	0.2 W	0.2 W	0.2 W	1.0 W	0.5 W
(0.8 to 1.1) U <sub>N</sub> AC (50/60 Hz)	(0.8 to 1.1) U <sub>N</sub> AC (50/60 Hz)	(0.8 to 1.1) U <sub>N</sub> AC (50/60 Hz)	(0.8 to 1.1) U <sub>N</sub> AC (50/60 Hz)	(0.8 to 1.1) U <sub>N</sub> AC (50/60 Hz)	(0.8 to 1.1) U <sub>N</sub> AC (50/60 Hz)
(0.8 to 1.2) U <sub>N</sub> DC	(0.8 to 1.2) U <sub>N</sub> DC	(0.8 to 1.2) U <sub>N</sub> DC	(0.8 to 1.2) U <sub>N</sub> DC	(0.8 to 1.2) U <sub>N</sub> DC	(0.8 to 1.2) U <sub>N</sub> DC
0.6 U <sub>N</sub> AC/0.6 U <sub>N</sub> DC	0.6 U <sub>N</sub> AC/0.6 U <sub>N</sub> DC	0.6 U <sub>N</sub> AC/0.6 U <sub>N</sub> DC	0.6 U <sub>N</sub> AC/0.6 U <sub>N</sub> DC	0.6 U <sub>N</sub> AC/0.6 U <sub>N</sub> DC	0.6 U <sub>N</sub> AC/ U <sub>N</sub> DC
0.1 U <sub>N</sub> AC/0.05 U <sub>N</sub> DC	0.1 U <sub>N</sub> AC/0.05 U <sub>N</sub> DC	0.1 U <sub>N</sub> AC/0.05 U <sub>N</sub> DC	0.1 U <sub>N</sub> AC/0.05 U <sub>N</sub> DC	0.1 U <sub>N</sub> AC/0.05 U <sub>N</sub> DC	0.1 U <sub>N</sub> AC/ U <sub>N</sub> DC

**PRC 48-60V AC/DC    PRC 48-60V AC/DC    PRC 110... 125V AC/DC    PRC 220... 240V AC/DC    PRC LW 110... 125V AC/DC    PRC LW 220... 240V AC**

<b>PRC 48-60V AC/DC</b> <b>15496.2/10</b>	<b>PRC 48-60V AC/DC</b> <b>15496.2/10</b>	<b>PRC 110... 125V AC/DC</b> <b>15497.2/10</b>	<b>PRC 220... 240V AC/DC</b> <b>15489.2/10</b>	<b>PRC LW 110... 125V AC/DC</b> <b>15555.2/10</b>	<b>PRC LW 220... 240V AC</b> <b>15491.2/10</b>
--	--	---	---	--	---

<b>PRC 1/48V DC</b> <b>15547.2/10*3</b>	<b>PRC 1/60V DC</b> <b>15503.2/10*3</b>	<b>PRC 1/60V DC</b> <b>15503.2/10*3</b>	<b>PRC 1/60V DC</b> <b>15503.2/10*3</b>	<b>PRC 1/60V DC</b> <b>15503.2/10*3</b>	<b>PRC 1/60V DC</b> <b>15503.2/10*3</b>
<b>AQI/PRC/20</b>	<b>AQI/PRC/20</b>	<b>AQI/PRC/20</b>	<b>AQI/PRC/20</b>	<b>AQI/PRC/20</b>	<b>AQI/PRC/20</b>
15545.8/1	15545.8/1	15545.8/1	15545.8/1	15545.8/1	15545.8/1
15545.5/1	15545.5/1	15545.5/1	15545.5/1	15545.5/1	15545.5/1
15545.4/1	15545.4/1	15545.4/1	15545.4/1	15545.4/1	15545.4/1

<b>TW/PRC</b>	<b>TW/PRC</b>	<b>TW/PRC</b>	<b>TW/PRC</b>	<b>TW/PRC</b>	<b>TW/PRC</b>
15546.2/1	15546.2/1	15546.2/1	15546.2/1	15546.2/1	15546.2/1

<b>PMC BSTR 6/30</b>	<b>PMC BSTR 6/30</b>	<b>PMC BSTR 6/30</b>	<b>PMC BSTR 6/30</b>	<b>PMC BSTR 6/30</b>	<b>PMC BSTR 6/30</b>
CONTA-CONNECT	CONTA-CONNECT	CONTA-CONNECT	CONTA-CONNECT	CONTA-CONNECT	CONTA-CONNECT
9106.7/300	9106.7/300	9106.7/300	9106.7/300	9106.7/300	9106.7/300
9107.7/300	9107.7/300	9107.7/300	9107.7/300	9107.7/300	9107.7/300

<b>SDB 0.6 x 3.5</b>	<b>SDB 0.6 x 3.5</b>	<b>SDB 0.6 x 3.5</b>	<b>SDB 0.6 x 3.5</b>	<b>SDB 0.6 x 3.5</b>	<b>SDB 0.6 x 3.5</b>
1086.0/1	1086.0/1	1086.0/1	1086.0/1	1086.0/1	1086.0/1

**Tension-spring relay terminals**

- Consisting of: basic terminal and pluggable relay.
- Mount on TS 35

**ZPRCU 1/6V DC**



**ZPRCU 1/12V DC**



**ZPRCU 1/24V DC**

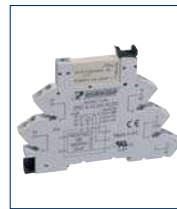

**ZPRCU 1/12V AC/DC**



**ZPRCU 1/24V AC/DC**

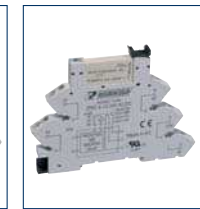

**Connection diagram**

- Internal EMC coil circuitry and LED display
- LW versions: an internal AC residual-current suppression and LED display

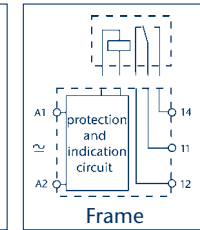
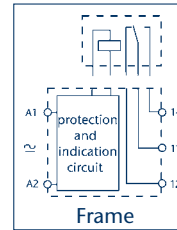
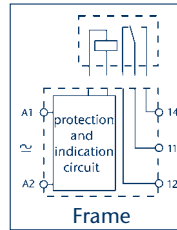
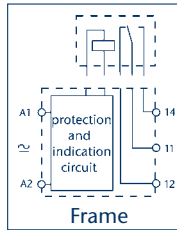
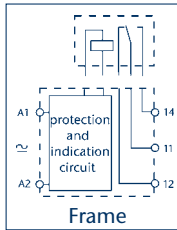

**Type**  
Cat. no./Qty. Type/Colour grey (RAL 7032)

Size (L x W x H) with TS 35 x 7.5

Weight

Rated operating voltage

**General information**

Mech. life span AC/DC switching cycles

Electrical life span AC 1 switching cycles

Response time/release time

Insulation coordination, EN 61810-5

Dielectric strength coil/contacts (1.2/50 μs)

Dielectric strength of open contacts

Ambient temperature

Relay protection type

**Ratings for socket base**

Ambient temperature

Insulation stripping length

Max. connection cross-section, solid | flexible mm<sup>2</sup>

AWG

**Ratings for plug-relays combined with socket base**

**Contacts**

Number of contacts

Max. continuous current | Max. inrush current

Rated voltage | Max. switching voltage

Max. power rating AC 1

Max. power rating AC 15 (230 V AC)

1-phase motor load, AC 3 operation (230 V AC)

Max. switching current DC 1:30/110/220 V

Min. switching load

Standard contact material

**Coil**

Rated voltage (U<sub>N</sub>)

Power rating AC/DC

Operating range

Holding current

Drop-out voltage

**ZPRCU 1/6V DC**

15524.2/10

93 x 6.2 x 79.9 mm

36 g

6 V DC

–/10 x 10<sup>6</sup>

60 x 10<sup>3</sup>

5/6 ms

4 kV/3

6 kV

1,000 V AC

–40 to +70 °C

RT II

–40 to +70 °C

10 mm

1x2.5/2x1.5 | 1x2.5/2x1.5

1x14/2x16 | 1x14/2x16

1 CO contact

6/10 A

250/400 V AC\*

1,500 VA

300 VA

0.185 kW

6/0.2/0.12 A

300 (5/5) mW (V/mA)

AqNi

5 V DC | – AC

0.2 W

–

(0.8 to 1.2) U<sub>N</sub> DC

0.6 U<sub>N</sub> DC

0.05 U<sub>N</sub> DC

**ZPRCU 1/12V DC**

15525.2/10

93 x 6.2 x 79.9 mm

36 g

12 V DC

–/10 x 10<sup>6</sup>

60 x 10<sup>3</sup>

5/6 ms

4 kV/3

6 kV

1,000 V AC

–40 to +70 °C

RT II

–40 to +70 °C

10 mm

1x2.5/2x1.5 | 1x2.5/2x1.5

1x14/2x16 | 1x14/2x16

1 CO contact

6/10 A

250/400 V AC\*

1,500 VA

300 VA

0.185 kW

6/0.2/0.12 A

300 (5/5) mW (V/mA)

AqNi

12 V DC | – AC

0.2 W

–

(0.8 to 1.2) U<sub>N</sub> DC

0.6 U<sub>N</sub> DC

0.05 U<sub>N</sub> DC

**ZPRCU 1/24V DC**

15526.2/10

93 x 6.2 x 79.9 mm

36 g

24 V DC

–/10 x 10<sup>6</sup>

60 x 10<sup>3</sup>

5/6 ms

4 kV/3

6 kV

1,000 V AC

–40 to +70 °C

RT II

–40 to +70 °C

10 mm

1x2.5/2x1.5 | 1x2.5/2x1.5

1x14/2x16 | 1x14/2x16

1 CO contact

6/10 A

250/400 V AC\*

1,500 VA

300 VA

0.185 kW

6/0.2/0.12 A

300 (5/5) mW (V/mA)

AqNi

24 V DC | – AC

0.2 W

–

(0.8 to 1.2) U<sub>N</sub> DC

0.6 U<sub>N</sub> DC

0.05 U<sub>N</sub> DC

**ZPRCU 1/12V AC/DC**

15518.2/10

93 x 6.2 x 79.9 mm

36 g

12 V AC/DC

10 x 10<sup>6</sup>/10 x 10<sup>6</sup>

60 x 10<sup>3</sup>

5/6 ms

4 kV/3

6 kV

1,000 V AC

–40 to +70 °C

RT II

–40 to +70 °C

10 mm

1x2.5/2x1.5 | 1x2.5/2x1.5

1x14/2x16 | 1x14/2x16

1 CO contact

6/10 A

250/400 V AC\*

1,500 VA

300 VA

0.185 kW

6/0.2/0.12 A

300 (5/5) mW (V/mA)

AqNi

12 V DC | 12 AC

0.2 W

(0.8 to 1.1) U<sub>N</sub> AC (50/60 Hz)

(0.8 to 1.2) U<sub>N</sub> DC

0.6 U<sub>N</sub> AC/0.6 U<sub>N</sub> DC

0.1 U<sub>N</sub> AC/0.05 U<sub>N</sub> DC

**ZPRCU 1/24V AC/DC**

15519.2/10

93 x 6.2 x 79.9 mm

36 g

24 V AC/DC

10 x 10<sup>6</sup>/10 x 10<sup>6</sup>

60 x 10<sup>3</sup>

5/6 ms

4 kV/3

6 kV

1,000 V AC

–40 to +70 °C

RT II

–40 to +70 °C

10 mm

1x2.5/2x1.5 | 1x2.5/2x1.5

1x14/2x16 | 1x14/2x16

1 CO contact

6/10 A

250/400 V AC\*

1,500 VA

300 VA

0.185 kW

6/0.2/0.12 A

300 (5/5) mW (V/mA)

AqNi

24 V DC | 24 AC

0.2 W

(0.8 to 1.1) U<sub>N</sub> AC (50/60 Hz)

(0.8 to 1.2) U<sub>N</sub> DC

0.6 U<sub>N</sub> AC/0.6 U<sub>N</sub> DC

0.1 U<sub>N</sub> AC/0.05 U<sub>N</sub> DC

**Individual components, socket base**

**Type/Colour grey (RAL 7032)**  
Cat. no./Qty.

**ZPRC 6-12-24V DC**  
15494.2/10

**ZPRC 6-12-24V DC**  
15494.2/10

**ZPRC 6-12-24V DC**  
15494.2/10

**ZPRC 6-12-24V AC/DC**  
15492.2/10

**ZPRC 6-12-24V AC/DC**  
15492.2/10

**Individual components, plug relays**

**Type/Rated voltage**  
Cat. no./Qty.

**PRC 1/5V DC**  
15500.2/10\*<sup>3</sup>

**PRC 1/12V DC**  
15501.2/10\*<sup>3</sup>

**PRC 1/24V DC**  
15502.2/10\*<sup>3</sup>

**PRC 1/12V DC**  
15501.2/10\*<sup>3</sup>

**PRC 1/24V DC**  
15502.2/10\*<sup>3</sup>

**Accessories** AOI/PRC external insulated cross-connector

Cat. no./Qty. yellow

Cat. no./Qty. blue

Cat. no./Qty. black

**AOI/PRC/20**

15545.8/1

15545.5/1

15545.4/1

**AOI/PRC/20**

15545.8/1

15545.5/1

15545.4/1

**AOI/PRC/20**

15545.8/1

15545.5/1

15545.4/1

**AOI/PRC/20**

15545.8/1

15545.5/1

15545.4/1

**AOI/PRC/20**

15545.8/1

15545.5/1

15545.4/1

**TW/PRC partitions**

Cat. no./Qty.

**TW/PRC**

15546.2/1

**TW/PRC**

15546.2/1

**TW/PRC**

15546.2/1

**TW/PRC**

**ZPRCU 1/48V AC/DC    ZPRCU 1/60V AC/DC    ZPRCU 1/125V AC/DC    ZPRCU 1/240V AC/DC    ZPRCU LW 1/125V AC/DC    ZPRCU LW 1/240V AC**

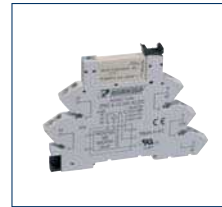
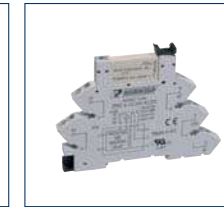
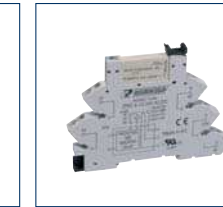
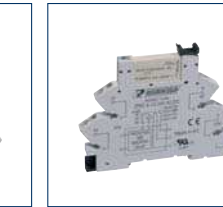
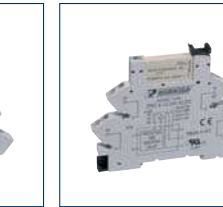
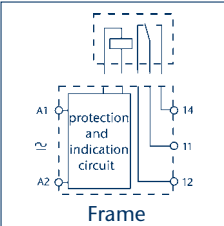
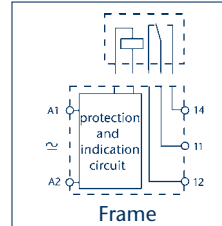
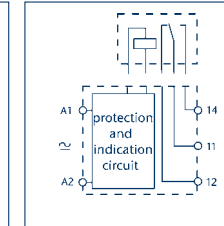
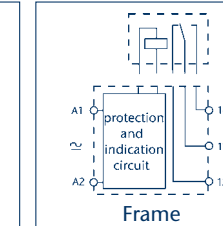
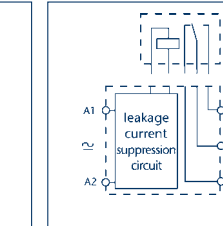
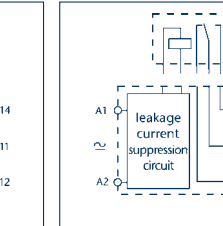
					
					
<b>ZPRCU 1/48V AC/DC</b> 15520.2/10 93 x 6.2 x 79.9 mm 36 g 48V AC/DC	<b>ZPRCU 1/60V AC/DC</b> 15521.2/10 93 x 6.2 x 79.9 mm 36 g 60V AC/DC	<b>ZPRCU 1/125V AC/DC</b> 15522.2/10*2 93 x 6.2 x 79.9 mm 36 g 125V AC/DC	<b>ZPRCU 1/240V AC/DC</b> 15523.2/10*2 93 x 6.2 x 79.9 mm 36 g 230V AC/DC	<b>ZPRCU LW 1/125V AC/DC</b> 15551.2/10*2 93 x 6.2 x 79.9 mm 36 g 125V AC/DC	<b>ZPRCU LW 1/240V AC</b> 15552.2/10*2 93 x 6.2 x 79.9 mm 36 g 230V AC
10 x 10 <sup>6</sup> /10 x 10 <sup>6</sup> 60 x 10 <sup>3</sup> 5/6 ms 4 kV/3 6 kV 1,000 V AC -40 to +70 °C RT II	10 x 10 <sup>6</sup> /10 x 10 <sup>6</sup> 60 x 10 <sup>3</sup> 5/6 ms 4 kV/3 6 kV 1,000 V AC -40 to +70 °C RT II	10 x 10 <sup>6</sup> /10 x 10 <sup>6</sup> 60 x 10 <sup>3</sup> 5/6 ms 4 kV/3 6 kV 1,000 V AC -40 to +70 °C RT II	10 x 10 <sup>6</sup> /10 x 10 <sup>6</sup> 60 x 10 <sup>3</sup> 5/6 ms 4 kV/3 6 kV 1,000 V AC -40 to +70 °C RT II	10 x 10 <sup>6</sup> /10 x 10 <sup>6</sup> 60 x 10 <sup>3</sup> 5/6 ms 4 kV/3 6 kV 1,000 V AC -40 to +70 °C RT II	10 x 10 <sup>6</sup> /10 x 10 <sup>6</sup> 60 x 10 <sup>3</sup> 5/6 ms 4 kV/3 6 kV 1,000 V AC -40 to +70 °C RT II
-40 to +70°C 10 mm 1x2.5/2x1.5   1x2.5/2x1.5 1x14/2x16   1x14/2x16	-40 to +70°C 10 mm 1x2.5/2x1.5   1x2.5/2x1.5 1x14/2x16   1x14/2x16	-40 to +70°C 10 mm 1x2.5/2x1.5   1x2.5/2x1.5 1x14/2x16   1x14/2x16	-40 to +70°C 10 mm 1x2.5/2x1.5   1x2.5/2x1.5 1x14/2x16   1x14/2x16	-40 to +70°C 10 mm 1x2.5/2x1.5   1x2.5/2x1.5 1x14/2x16   1x14/2x16	-40 to +70°C 10 mm 1x2.5/2x1.5   1x2.5/2x1.5 1x14/2x16   1x14/2x16
1 CO contact 6/10 A 250/400 V AC* 1,500 VA 300 VA 0.185 kW 6/0.2/0.12 A 300 (5/5) mW (V/mA) AgNi	1 CO contact 6/10 A 250/400 V AC* 1,500 VA 300 VA 0.185 kW 6/0.2/0.12 A 300 (5/5) mW (V/mA) AgNi	1 CO contact 6/10 A 250/400 V AC* 1,500 VA 300 VA 0.185 kW 6/0.2/0.12 A 300 (5/5) mW (V/mA) AgNi	1 CO contact 6/10 A 250/400 V AC* 1,500 VA 300 VA 0.185 kW 6/0.2/0.12 A 300 (5/5) mW (V/mA) AgNi	1 CO contact 6/10 A 250/400 V AC* 1,500 VA 300 VA 0.185 kW 6/0.2/0.12 A 300 (5/5) mW (V/mA) AgNi	1 CO contact 6/10 A 250/400 V AC* 1,500 VA 300 VA 0.185 kW 6/0.2/0.12 A 300 (5/5) mW (V/mA) AgNi
48 V DC   48 AC 0.2 W (0.8 to 1.1) U <sub>N</sub> AC (50/60 Hz) (0.8 to 1.2) U <sub>N</sub> DC 0.6 U <sub>N</sub> AC/0.6 U <sub>N</sub> DC 0.1 U <sub>N</sub> AC/0.05 U <sub>N</sub> DC	60 V DC   60 AC 0.2 W (0.8 to 1.1) U <sub>N</sub> AC (50/60 Hz) (0.8 to 1.2) U <sub>N</sub> DC 0.6 U <sub>N</sub> AC/0.6 U <sub>N</sub> DC 0.1 U <sub>N</sub> AC/0.05 U <sub>N</sub> DC	110...125 V DC   110...125 AC 0.2 W (0.8 to 1.1) U <sub>N</sub> AC (50/60 Hz) (0.8 to 1.2) U <sub>N</sub> DC 0.6 U <sub>N</sub> AC/0.6 U <sub>N</sub> DC 0.1 U <sub>N</sub> AC/0.05 U <sub>N</sub> DC	220...240 V DC   220...240 AC 0.2 W (0.8 to 1.1) U <sub>N</sub> AC (50/60 Hz) (0.8 to 1.2) U <sub>N</sub> DC 0.6 U <sub>N</sub> AC/0.6 U <sub>N</sub> DC 0.1 U <sub>N</sub> AC/0.05 U <sub>N</sub> DC	110...125 V DC   110...125 AC 1.0 W (0.8 to 1.1) U <sub>N</sub> AC (50/60 Hz) (0.8 to 1.2) U <sub>N</sub> DC 0.6 U <sub>N</sub> AC/0.6 U <sub>N</sub> DC 0.1 U <sub>N</sub> AC/0.05 U <sub>N</sub> DC	- V DC   220...240 AC 0.5 W (0.8 to 1.1) U <sub>N</sub> AC (50/60 Hz) (0.8 to 1.2) U <sub>N</sub> DC 0.6 U <sub>N</sub> AC/ - U <sub>N</sub> DC 0.1 U <sub>N</sub> AC/ - U <sub>N</sub> DC

**ZPRC 48-60V AC/DC    ZPRC 48-60V AC/DC    ZPRC 110...125V AC/DC    ZPRC 220...240V AC/DC    ZPRC LW 110...125 V AC/DC    ZPRC LW 220...240V A**

15498.2/10	15498.2/10	15499.2/10	15493.2/10	15556.2/10	15495.2/10
------------	------------	------------	------------	------------	------------

**PRC 1/48V DC    PRC 1/60V DC    PRC 1/60V DC    PRC 1/60V DC    PRC 1/60V DC    PRC 1/60V DC**

15547.2/10*3	15503.2/10*3	15503.2/10*3	15503.2/10*3	15503.2/10*3	15503.2/10*3
<b>AQI/PRC/20</b>	<b>AQI/PRC/20</b>	<b>AQI/PRC/20</b>	<b>AQI/PRC/20</b>	<b>AQI/PRC/20</b>	<b>AQI/PRC/20</b>
15545.8/1 15545.5/1 15545.4/1	15545.8/1 15545.5/1 15545.4/1	15545.8/1 15545.5/1 15545.4/1	15545.8/1 15545.5/1 15545.4/1	15545.8/1 15545.5/1 15545.4/1	15545.8/1 15545.5/1 15545.4/1

**TW/PRC    TW/PRC    TW/PRC    TW/PRC    TW/PRC    TW/PRC**

15546.2/1	15546.2/1	15546.2/1	15546.2/1	15546.2/1	15546.2/1
<b>PMC BSTR 6/30</b> CONTA-CONNECT 9106.7/300 9107.7/300	<b>PMC BSTR 6/30</b> CONTA-CONNECT 9106.7/300 9107.7/300	<b>PMC BSTR 6/30</b> CONTA-CONNECT 9106.7/300 9107.7/300	<b>PMC BSTR 6/30</b> CONTA-CONNECT 9106.7/300 9107.7/300	<b>PMC BSTR 6/30</b> CONTA-CONNECT 9106.7/300 9107.7/300	<b>PMC BSTR 6/30</b> CONTA-CONNECT 9106.7/300 9107.7/300

**BWMA 1    BWMA 1    BWMA 1    BWMA 1    BWMA 1    BWMA 1**

3808.0/1	3808.0/1	3808.0/1	3808.0/1	3808.0/1	3808.0/1
----------	----------	----------	----------	----------	----------

## Compact plug relays PRC

### Relay terminals with 2-CO relays

The new **PRC 2W** relay bases enable the integration of relays with two CO contacts into the proven **PRC** relay system. This base also features the well-known advantages of this system, including simple bridging with jumpers and a thin design. They are available either with tension-spring or screw connection. Dependable functioning is always certain because of the combination with the proven **PRS**-system relays.

#### 1. Overview

**b Pluggable relays**  
Pluggable relays are also available with AgSNO and gold contacts, to fit with the many functions of your individual requirements!



**a Using the mount/dismount lever**  
The mounting and dismounting mechanism forms a reliable connection by latching the relay with the socket base. The fitted relay can be removed, easily and without force, from the socket base by using the dismount function of the lever!



**d Mounts on standard TS 35 rail**  
**CONTA-CLIP** relay terminal can be flexibly mounted on standard TS 35 mounting rails according to EN 50035 and EN 50022.

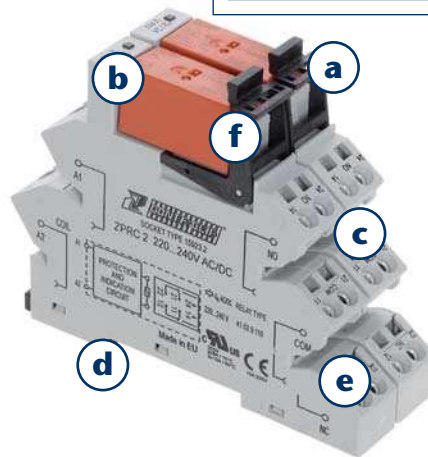

**c Pluggable external cross-connections**  
The **AQI / PRC** pluggable cross-connection system enables a time-saving distribution of potentials. The **AQI / PRC** is constructed so that it is protected against accidental touch. It is available as a 8-pole unit, in either yellow, blue or black. The cross-connector can be shortened to fewer poles in order to fit the required interface. Insulation plating can be used to insulate the ends.



**e Connection types**  
All of our relay terminals are optionally available with screw or tension-spring connection systems.



**f Labelling | Marking**  
The socket bases have a labelling surface which is optimally suited for our PMC Pocket-Maxicard (**MC GS 6x12 R**) standard marking system. **CONTA-CLIP** can also provide "just-in-time" individual labelling for you.

#### 2. Approvals (Details upon request)



#### 3. Features

##### 1. Socket base

- Mount on TS 35
- Very flexible and modular construction of individual relay bases
- User-friendly, because the relays can be easily replaced
- High-quality connection terminals (Tension-spring or screw connection system)
- Integrated EMC coil circuitry, and LED
- High-quality innovative mount/dismount lever
- All versions are available either with the screw or tension-spring connection system

##### Tension-spring connection

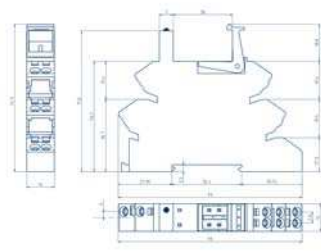

##### Screw connection

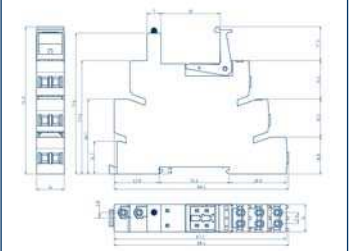

# Compact plug relays PRC

## Relay terminals with 2-CO relays

### II. Relay

- PLUG RELAY SYSTEM relay 2-CO
- Load-independent switching
- Direct control via the PLC outputs
- High interference immunity
- Electrical isolation of control and load circuits
- Minimal contact resistance, and high insulation resistance

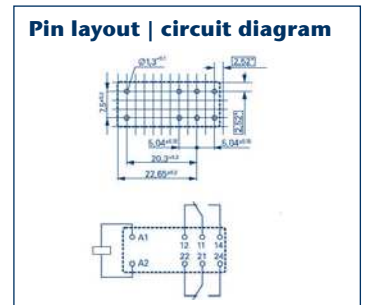
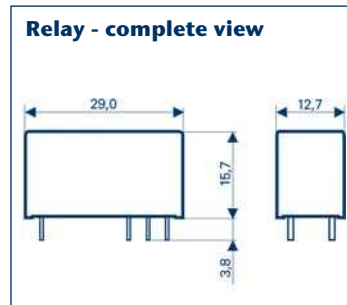

## 4. Specifications

Insulation data			Flammability class acc. to UL94	
Dielectric strength	Coil-contact arrangement	5000 Veff		V0
	Opened contact	1000 Veff		
	Adjacent contacts	2500 Veff		
Clearance/creepage distances	Coil-contact arrangement	≤ 10 / 10 mm	Ambient temperature range	
	Adjacent contacts	≤ 3 / 4 mm	-40/+85°C	
Insulating material group		≤ IIIa	Response/release time of DC coil	
Creep resistance of carrier		PTI 250 V	typ. 7 / 2 ms	
Insulation acc. to IEC 60664-1			Bounce time of DC spool, NO / NC	
Type of insulation	Coil-contact arrangement	Strengthened insul.	typ. 1 / 3 ms	
	Opened contact	Functional insul.	Fatigue strength (functional), NO / NC	
	Adjacent contacts	Basic insul.	20 / 5 g, 30 – 500 Hz	
Rated voltage		250 V	Shock resistance (destructive)	
Pollution degree		3	100 g	
Nominal volt. of the supply system		240/400 V	Protection	
Overvoltage category		III	RTII	
			Mounting interval	
			0 mm, dens. packaged	
			Weight	
			14 g	

## 5. Contact data

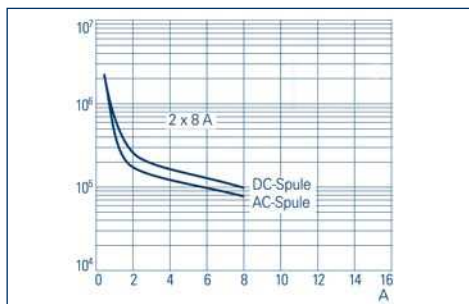

Contact life span under 250 V AC resistive load

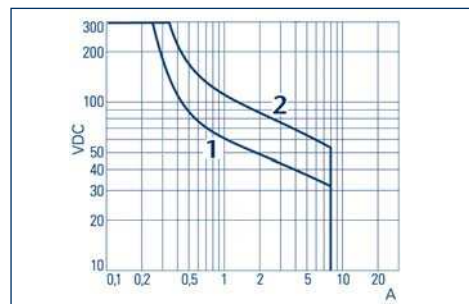

Switching capacity under DC load

Resistive load

1 one contact

2 two contacts in series

## 6. Coil data

### DC version

Rated voltage	Operating Range		Resistance	Rated current
	$U_N$	$U_{min}$		
V	V	V	$R$	I
			$\Omega$	mA
5	3.5	0.5	62 ± 10%	403
6	4.20	0.6	90 ± 10%	400
12	8.4	1.2	360 ± 10%	400
24	16.80	2.4	1440 ± 10%	400
48	33.60	4.8	5520 ± 10%	417
60	42.00	6.0	8570 ± 12%	420
110	77.0	11.0	28800 ± 13%	420

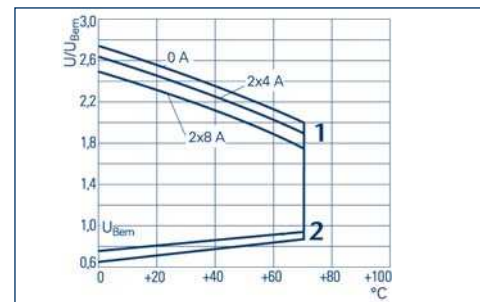



Reliable range of operating voltage

1 Max. permitted coil voltage

2 Response voltage, when coil temperature equal to ambient temperature

## Compact plug relays PRC

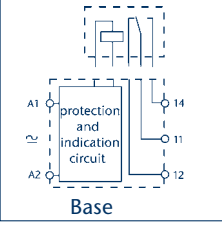
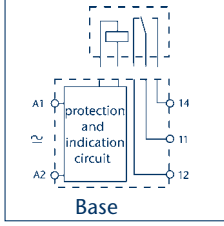
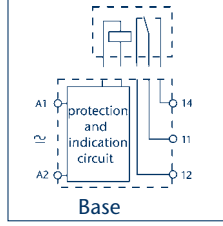

Relay terminal tension-spring/screw connection	PRCU 2/12V AC/DC	PRCU 2/24V AC/DC	PRCU 2/240V AC/DC	
<ul style="list-style-type: none"> <li>consisting of:</li> <li>Basic terminal and pluggable relay</li> <li>Mount on TS 35</li> </ul>				
<b>Connection diagram</b>				
<ul style="list-style-type: none"> <li>Internal EMC coil circuitry and LED display</li> </ul>				
<b>Type</b>	<b>PRCU 2/12V AC/DC</b>	<b>PRCU 2/24V AC/DC</b>	<b>PRCU 2/240V AC/DC</b>	
<b>Cat. no./Qty.</b>	<b>15924.2/1</b>	<b>15925.2/1</b>	<b>15926.2/1</b>	
Size (L x W x H) with TS 35	92 x 14 x 82 mm	92 x 14 x 82 mm	92 x 14 x 82 mm	
Weight	68 g	68 g	68 g	

Type	PRS 2/12 V DC	PRS 2/24 V DC	PRS 2/110 V DC	
<b>Cat. no./Qty.</b>	<b>6482.2/1</b>	<b>6483.2/1</b>	<b>15541.2/1</b>	
Weight	15 g	15 g	15 g	
<b>General information</b>				
DIN-VDE specifications	Insulation IEC 664/VDE 0110, rated voltage 250 V, pollution degree 3, overvoltage category III, flammability class UL 94 V-0			
Test voltage coil/contact	5 kV	5 kV	5 kV	
Pinning	5 mm	5 mm	5 mm	
Operating temperature	-40 to +70°C	-40 to +70°C	-40 to +70°C	
<b>Input data</b>				
Input voltage	12 V DC	24 V DC	110 V DC	
Rated power consumption	0.40 W	0.40 W	0.40 W	
<b>Output data</b>				
Contacts	2 CO contacts	2 CO contacts	2 CO contacts	
Switching voltage/Max. switching voltage	240 V AC/400 V AC	240 V AC/400 V AC	240 V AC/400 V AC	
Max continuous current/inrush current	8 A/15 A	8 A/15 A	8 A/15 A	
Typical response time/release time	7 ms/2 ms	7 ms/2 ms	7 ms/2 ms	
Contact material	AgNi 90/10	AgNi 90/10	AgNi 90/10	
Electrical life span	1.5 x 10 <sup>5</sup>	1.5 x 10 <sup>5</sup>	1.5 x 10 <sup>5</sup>	
At contact load	4 A, 230 V AC	4 A, 230 V AC	4 A, 230 V AC	
Mechanical life span	>30 x 10 <sup>6</sup>	>30 x 10 <sup>6</sup>	>30 x 10 <sup>6</sup>	

Type	PRC 2 6-12-24V AC/DC	PRC 2 6-12-24V AC/DC	PRC 2 220 – 240V AC/DC	
<b>Cat. no./Qty.</b>	<b>15920.2/10</b>	<b>15920.2/10</b>	<b>15921.2/10</b>	
Weight	53 g	53 g	53 g	
<b>General</b>				
Mounting foot for DIN rails	TS 35	TS 35	TS 35	
Plug-in base for	5 mm pinning	5 mm pinning	5 mm pinning	
Connection type	Screw connection	Screw connection	Screw connection	
<b>Technical data</b>				
Rated current	10 A	10 A	10 A	
Rated voltage	250 V	250 V	250 V	
Dielectric strength coil/contact	6 kv (1.2/50 μs)	6 kv (1.2/50 μs)	6 kv (1.2/50 μs)	
Ambient temperature	-40 to +70°C	-25 to +70°C	-40 to +55°C	
Protection degree, enclosure	IP 20	IP 20	IP 20	
Flammability class UL 94	V-0	V-0	V-0	
Torque	0.5 Nm	0.5 Nm	0.5 Nm	
Connection cross-section, solid, max.	1x6/2x2.5mm <sup>2</sup> 1x10/2x14 AWG	1x6/2x2.5mm <sup>2</sup> 1x10/2x14 AWG	1x6/2x2.5mm <sup>2</sup> 1x10/2x14 AWG	
Connection cross-section, stranded, max.	1x4/2x2.5mm <sup>2</sup> 1x12/2x14 AWG	1x4/2x2.5mm <sup>2</sup> 1x12/2x14 AWG	1x4/2x2.5mm <sup>2</sup> 1x12/2x14 AWG	
Insulation stripping length	8 mm	8 mm	8 mm	
Approvals	UL/CUL	UL/CUL	UL/CUL	

Accessories AQI/PRC external insulated cross-connector	AQI/PRC/8	AQI/PRC/8	AQI/PRC/8	
<b>Cat. no./Qty.</b> yellow	<b>15930.8/1</b>	<b>15930.8/1</b>	<b>15930.8/1</b>	
<b>Cat. no./Qty.</b> blue	<b>15930.5/1</b>	<b>15930.5/1</b>	<b>15930.5/1</b>	
<b>Cat.-No./Qty.</b> black	<b>15930.4/1</b>	<b>15930.4/1</b>	<b>15930.4/1</b>	
<b>TW/PRC partitions</b>	<b>TW/PRC</b>	<b>TW/PRC</b>	<b>TW/PRC</b>	
<b>Cat. no./Qty.</b>	<b>15546.2/1</b>	<b>15546.2/1</b>	<b>15546.2/1</b>	
<b>Tool/screw driver</b>	<b>SDB 0,6 x 3,5</b>	<b>SDB 0,6 x 3,5</b>	<b>SDB 0,6 x 3,5</b>	
<b>Cat. no./Qty.</b>	<b>1086.0/1</b>	<b>1086.0/1</b>	<b>1086.0/1</b>	
<b>MC labelling / markers</b>	<b>MC GS 6x12 R</b>	<b>MC GS 6x12 R</b>	<b>MC GS 6x12 R</b>	
<b>Cat. no./Qty.</b> , blank	<b>3884.7/600</b>	<b>3884.7/600</b>	<b>3884.7/600</b>	
<b>Cat. no./Qty.</b> , special print	<b>3885.7/600</b>	<b>3885.7/600</b>	<b>3885.7/600</b>	

# Compact plug relays PRC

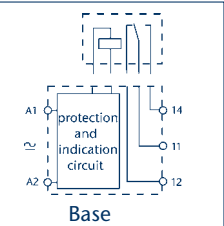
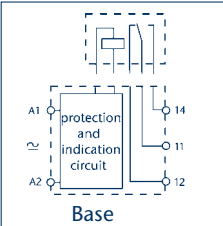
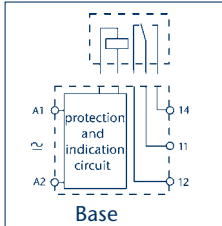
ZPRCU 2/12V AC/DC	ZPRCU 2/24V AC/DC	ZPRCU 2/240V AC/DC			
					
					
<b>ZPRCU 2/12V AC/DC</b> <b>15927.2/1</b> 93 x 14 x 82 mm 63 g	<b>ZPRCU 2/24V AC/DC</b> <b>15928.2/1</b> 93 x 14 x 82 mm 63 g	<b>ZPRCU 2/240V AC/DC</b> <b>15929.2/1</b> 93 x 14 x 82 mm 63 g			

PRS 2/12 V DC	PRS 2/24 V DC	PRS 2/110 V DC			
<b>6482.2/1</b>	<b>6483.2/1</b>	<b>15541.2/1</b>			
15 g	15 g	15 g			
Insulation IEC 664/VDE 0110, rated voltage 250 V, pollution degree 3, overvoltage category III, flammability class UL 94 V-0					
5 kV	5 kV	5 kV			
5 mm	5 mm	5 mm			
-40 to +70°C	-40 to +70°C	-40 to +70°C			
12 V DC	24 V DC	110 V DC			
0.40 W	0.40 W	0.40 W			
2 CO contacts	2 CO contacts	2 CO contacts			
240 V AC/400 V AC	240 V AC/400 V AC	240 V AC/400 V AC			
8 A/15 A	8 A/15 A	8 A/15 A			
7 ms/2 ms	7 ms/2 ms	7 ms/2 ms			
AgNi 90/10	AgNi 90/10	AgNi 90/10			
1.5 x 10 <sup>5</sup>	1.5 x 10 <sup>5</sup>	1.5 x 10 <sup>5</sup>			
4 A, 230 V AC	4 A, 230 V AC	4 A, 230 V AC			
>30 x 10 <sup>6</sup>	>30 x 10 <sup>6</sup>	>30 x 10 <sup>6</sup>			

ZPRC 2 6-12-24V AC/DC	ZPRC 2 6-12-24V AC/DC	ZPRC 2 220-240V AC/DC			
<b>15922.2/10</b>	<b>15922.2/10</b>	<b>15923.2/10</b>			
48 g	48 g	48 g			
TS 35	TS 35	TS 35			
5 mm pinning	5 mm pinning	5 mm pinning			
Tension-spring connection	Tension-spring connection	Tension-spring connection			
10 A	10 A	10 A			
250 V	250 V	250 V			
6 kv (1.2/50 μs)	6 kv (1.2/50 μs)	6 kv (1.2/50 μs)			
-40 to +70°C	-40 to +70°C	-40 to +55°C			
IP 20	IP 20	IP 20			
V-0	V-0	V-0			
-	-	-			
1 x 2.5 mm <sup>2</sup>  1x14 AWG	1 x 2.5 mm <sup>2</sup>  1x14 AWG	1 x 2.5 mm <sup>2</sup>  1x14 AWG			
1 x 2.5 mm <sup>2</sup>  1x14 AWG	1 x 2.5 mm <sup>2</sup>  1x14 AWG	1 x 2.5 mm <sup>2</sup>  1x14 AWG			
8 mm	8 mm	8 mm			
UL/CUL	UL/CUL	UL/CUL			

AQI/PRC/8	AQI/PRC/8	AQI/PRC/8			
<b>15930.8/1</b>	<b>15930.8/1</b>	<b>15930.8/1</b>			
<b>15930.5/1</b>	<b>15930.5/1</b>	<b>15930.5/1</b>			
<b>15930.4/1</b>	<b>15930.4/1</b>	<b>15930.4/1</b>			
TW/PRC	TW/PRC	TW/PRC			
<b>15546.2/1</b>	<b>15546.2/1</b>	<b>15546.2/1</b>			
BWMA 1	BWMA 1	BWMA 1			
<b>3808.0/1</b>	<b>3808.0/1</b>	<b>3808.0/1</b>			
MC GS 6x12 R	MC GS 6x12 R	MC GS 6x12 R			
<b>3884.7/600</b>	<b>3884.7/600</b>	<b>3884.7/600</b>			
<b>3885.7/600</b>	<b>3885.7/600</b>	<b>3885.7/600</b>			

## Plug relay system PRS

### Screw-clamp connection

#### 1. Overview

**a Pluggable relays**  
Pluggable relays are also available with AgSNO and gold contacts, to fit with the many functions of your individual requirements!



**e Mounts on standard TS 35 rail**  
**CONTA-CLIP** relay bases can be flexibly mounted on standard TS 35 mounting rails according to EN 50035 and EN 50022.

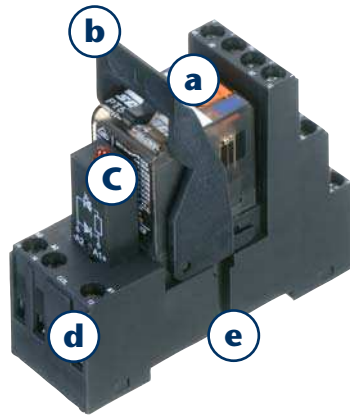

**b Using the mount/dismount lever**  
The mounting and dismounting mechanism forms a reliable connection by latching the relay with the socket base. The fitted relay can be removed, easily and without force, from the socket base by using the dismount function of the lever!

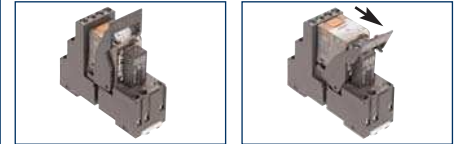

#### AQI/PRS external cross-connector

**d** The AQI/PRS external cross-connection system enables a time-saving distribution of potentials. With this system, you can save time when coupling multiple relay components.

**c Pluggable LED and protective modules**  
Pluggable modules allow easy insertion into the base module, with reverse-connect protection. Their circuitry is effective in parallel to the coil of the deployed relay.



#### 2. Features

##### 1. Relay

- **PLUG RELAY SYSTEM** (relays with 1, 2, or 4 COs)
- Load-independent switching
- Direct control via the SPS outputs
- High interference immunity
- Electrical isolation of control and load circuits
- Minimal contact resistance, and high insulation resistance
- PRS XT relay features switch/button for HAND/AUTOMATIC switching and an integrated LED to show the status of the switch
- PRS 4 relay features switch/button for HAND/AUTOMATIC switching
- PRS 4 eco relay features switch/button for HAND/AUTOMATIC switching, and an integrated LED for signalling the switching status

Technical data for the available relays can be found on the following product pages.



# Plug relay system PRS

## Screw-clamp connection

### II. Socket base

- Mount on TS 35
- Very flexible and modular construction of individual relay bases
- User-friendly, because the relays can be easily replaced
- High-quality connection terminals
- Wire strands protected against false insertion
- Terminal screws retention prevents loss
- Pluggable LED display with additional protective circuitry
- Holding clamp made of high-quality plastic

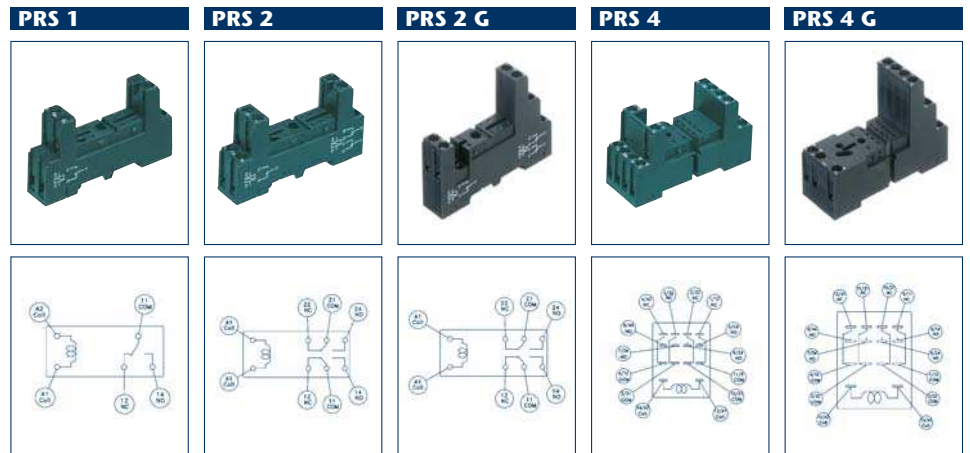

Type	PRS 1	PRS 2	PRS 2 G	PRS 4	PRS 4 G
<b>Cat. no./Qty.</b>	<b>15135.2/1</b>	<b>15136.2/1</b>	<b>15320.2/1</b>	<b>15137.2/1</b>	<b>15324.2/1</b>
Size (L x W x H) with TS 35	76 x 15.7 x 46 mm	76 x 15.7 x 46 mm	76 x 15.7 x 65 mm	76 x 27.1 x 47 mm	76 x 27.1 x 66 mm
Size with holding clamp (L x W x H) with TS 35	76 x 15.7 x 71 mm	76 x 15.7 x 71 mm	76 x 15.7 x 71 mm	76 x 27.1 x 85 mm	76 x 27.1 x 87 mm
Weight	33 g	38 g	43 g	63 g	65 g
<b>General</b>					
Mounting foot for DIN rails	TS 35	TS 35	TS 35	TS 35	TS 35
Plug-in modules for	3.5mm pinning	5mm pinning	5mm pinning	2.8mm fast-on	2.8mm fast-on
Connection type	Screw connection	Screw connection	Screw connection	Screw connection	Screw connection
<b>Technical data</b>					
Rated current	12 A	10 A	10 A	10 A	10 A
Rated voltage	300 V	300 V	300 V	300 V	300 V
Dielectric strength coil/contact	4000 Veff	4000 Veff	4000 Veff	2400 Veff	2400 Veff
Insulation group (VDE 0110 b)	C/250 V	C/250 V	C/250 V	C/250 V	C/250 V
Ambient temperature	-25 to +80°C	-25 to +80°C	-25 to +80°C	-25 to +80°C	-25 to +80°C
Protection degree, enclosure	IP 20	IP 20	IP 20	IP 20	IP 20
Flammability class UL 94	V-0	V-0	V-0	V-0	V-0
Touch protection, acc. to	VBG 4	VBG 4	VBG 4	VBG 4	VBG 4
Connection cross-section	2 x 2.5 mm <sup>2</sup>	2 x 2.5 mm <sup>2</sup>	2 x 2.5 mm <sup>2</sup>	2 x 2.5 mm <sup>2</sup>	2 x 2.5 mm <sup>2</sup>
With ferrules	2 x 1.5 mm <sup>2</sup>	2 x 1.5 mm <sup>2</sup>	2 x 1.5 mm <sup>2</sup>	2 x 1.5 mm <sup>2</sup>	2 x 1.5 mm <sup>2</sup>
Screw torque	max. 0.8 Nm	max. 0.8 Nm	max. 0.8 Nm	max. 0.8 Nm	max. 0.8 Nm
Approvals	UL/CSA	UL/CSA	UL/CSA	UL/CSA	UL/CSA

### III. Insert modules

- Plugs simply into the base, reverse-connect protection
- Circuitry parallel to coil

Cat. no./Qty.	Type	Voltage range	
<b>15141.2/1</b>	PRS LED(RD) 24V DC	12 to 24 V DC	Status display with free-wheel diode
<b>15142.2/1</b>	PRS LED(RD) 230V AC	110 to 230 V AC	Status display
<b>15175.2/1</b>	PRS LED(RD) 24V UC	12 to 48 V AC/DC	Status display
<b>15422.2/1</b>	PRS LED(RD)/110V DC	60 to 110 V DC	Status display with free-wheel diode
<b>15810.2/1</b>	PRS LED(RD) 230V UC Var.	24 V AC/DC	Status display with varistor
<b>16070.2/1</b>	PRS LED(GN) 24V UC Var.	230 V AC/DC	Status display with varistor
<b>15808.2/1</b>	PRS RC 24V AC	24 V AC	Plug-in module with RC element
<b>15809.2/1</b>	PRS RC 240V AC	240 V AC	Plug-in module with RC element

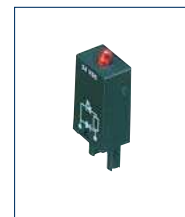

### IV. Holding clamp

The mount/dismount clamp forms a reliable connection by latching the relay with the socket base. The fitted relay can be removed, easily and without force, from the socket base by using the dismount function of the lever.

Cat. no./Qty.	Type	Weight
<b>15138.2/1</b>	PRS C 1/C 2	2 g
<b>15140.2/1</b>	PRS C 4	4 g
<b>15628.2/1</b>	PRS C 4 eco	4 g
<b>16016.2/1</b>	PRSXT C1/2	4 g

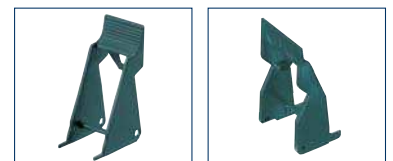



### V. Contact bridge

- A simple and quick bridge to multiple relay blocks

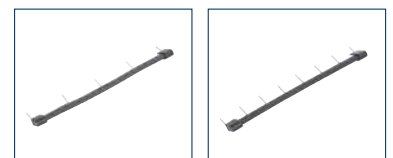
Cat. no./Qty.	Type	Weight
<b>15778.2/1</b>	AQI PRS/5	A contact bridge, for bridging five PRS 4 4 CO frames
<b>15779.2/1</b>	AQI PRS/8	A contact bridge for bridging up to 8 PRS 1 or PRS 2 1 and 2 CO frames



## Relay 1-CO PRS 1 XT

Complete screw-connection units consisting of:	PRSUXT 1/24V DC	PRSUXT 1/24V AC	PRSUXT 1/230V DC	PRSUXT 1G/24V DC
<ul style="list-style-type: none"> <li>Relay</li> <li>Socket base</li> <li>Holding clamp</li> </ul>				
Type	PRSUXT 1/24V DC	PRSUXT 1/24V AC	PRSUXT 1/230V DC	PRSUXT 1G/24V DC
Cat. no./Qty.	16086.2 / 1	16087.2 / 1	16088.2 / 1	16089.2 / 1
Size (L x W x H) with TS 35 x 7.5	76 x 15.7 x 76 mm	76 x 15.7 x 76 mm	76 x 15.7 x 76 mm	76 x 15.7 x 76 mm
Weight	56g	56g	56g	56g

### Individual components Relay 1W, open design, with switch and status display



Type	PRSXT 1/24V DC	PRSXT 1/24V AC	PRSXT 1/230V DC	PRSXT 1/24V DC
Cat. no./Qty.	16083.2 / 1	16084.2 / 1	16085.2 / 1	16083.2 / 1
Dimensions (L x W x H)	29 x 13 x 30.55 mm	29 x 13 x 30.55 mm	29 x 13 x 30.55 mm	29 x 13 x 30.55 mm
Weight	16g	16g	16g	16g
Common data				
DIN-VDE specifications	Insulation IEC 664/VDE 0110, Rated voltage 250 V, contamination degree 3, Overvoltage category III, Flammability class UL 94 V-0			
Test voltage coil/contact	2.5 KV	2.5 KV	2.5 KV	2.5 KV
Operating temperature	-40 to +70°C	-40 to +70°C	-40 to +70°C	-40 to +70°C
Lockable test button	yes	yes	yes	yes
Indicators	red LED	red LED	red LED	red LED
Mechanical indicator	yes	yes	yes	yes
Free-wheel diode	yes	no	no	yes
Input data				
Input voltage	24 V DC	24V AC	230V AC	24 V DC
Rated power consumption	0.4W	0.76VA	0.74VA	0.4W
Frequency	-	50/60 Hz	50/60 Hz	-
Output specifications				
Contacts	1 CO contact	1 CO contact	1 CO contact	1 CO contact
Switching voltage/Max. switching voltage	240 V AC/400 V AC	240 V AC/400 V AC	240 V AC/400 V AC	240 V AC/400 V AC
Max. continuous current	16 A, 240 V AC	16 A, 240 V AC	16 A, 240 V AC	16 A, 240 V AC
Max. inrush current 4s / 30 ms	30 A /300 A	30 A /300 A	30 A /300 A	30 A /300 A
Max. contact load	4000 VA	4000 VA	4000 VA	4000 VA
Min. suggested contact load	12V at 10mA	12V at 10mA	12V at 10mA	12V at 10mA
Voltage drop	30mV at 100mA/6VDC	30mV at 100mA/6VDC	30mV at 100mA/6VDC	30mV at 100mA/6VDC
Max. switching frequency at operating load	360 Cycles per hour	360 Cycles per hour	360 Cycles per hour	360 Cycles per hour
Max. switching frequency without load	36000 Cycles per hour	36000 Cycles per hour	36000 Cycles per hour	36000 Cycles per hour
Typical response time/release time	8 ms/6 ms	8 ms/6 ms	8 ms/6 ms	8 ms/6 ms
Contact material	AgNi 90/10	AgNi 90/10	AgNi 90/10	AgNi 90/10
Electrical service life	50 x 10 <sup>3</sup>	50 x 10 <sup>3</sup>	50 x 10 <sup>3</sup>	50 x 10 <sup>3</sup>
Mechanical service life	10 x 10 <sup>6</sup>	5 x 10 <sup>6</sup>	5 x 10 <sup>6</sup>	10 x 10 <sup>6</sup>

### Socket base

Type	PRS 2	PRS 2	PRS 2	PRS 2 G
Cat. no./Qty.	15136.2 / 1	15136.2 / 1	15136.2 / 1	15320.2 / 1
Overview				
Mounting foot for DIN rails	TS 35	TS 35	TS 35	TS 35
Plug-in base for	5mm pinning	5mm pinning	5mm pinning	5mm pinning
Connection type	Screw connection	Screw connection	Screw connection	Screw connection
Technical data				
Rated current	10A	10A	10A	10A
Rated voltage	300 V	300 V	300 V	300 V
Dielectric strength	4000 Veff	4000 Veff	4000 Veff	4000 Veff
Insulation group (VDE 0110b)	C/250 V	C/250 V	C/250 V	C/250 V
Ambient temperature	-25... +80°C	-25... +80°C	-25... +80°C	-25... +80°C
Protection degree, enclosure	IP 20	IP 20	IP 20	IP 20
Flammability class UL 94	V-0	V-0	V-0	V-0
Touch protection, acc. to	VBG 4	VBG 4	VBG 4	VBG 4
Connection cross-section	2 x 2.5 mm <sup>2</sup>	2 x 2.5 mm <sup>2</sup>	2 x 2.5 mm <sup>2</sup>	2 x 2.5 mm <sup>2</sup>
With ferrules	2 x 1.5 mm <sup>2</sup>	2 x 1.5 mm <sup>2</sup>	2 x 1.5 mm <sup>2</sup>	2 x 1.5 mm <sup>2</sup>
Screw torque	max. 0.8 Nm	max. 0.8 Nm	max. 0.8 Nm	max. 0.8 Nm
Stripping length	7 mm	7 mm	7 mm	7 mm
Approvals	UL/CSA	UL/CSA	UL/CSA	UL/CSA

### Holding clamp

Type	PRSXT C1/2	PRSXT C1/2	PRSXT C1/2	PRSXT C1/2
Cat. no./Qty.	16016.2 / 20	16016.2 / 20	16016.2 / 20	16016.2 / 20





<b>PRSUXT 1G/24V AC</b>	<b>PRSUXT 1/230V DC</b>				
					
<b>PRSUXT 1G/24V AC</b> <b>16090.2 / 1</b> 76 x 15.7 x 76 mm 56g	<b>PRSUXT 1G/230V AC</b> <b>16091.2 / 1</b> 76 x 15.7 x 76 mm 56g				

<b>PRSXT 1/24V AC</b> <b>16084.2 / 1</b> 29 x 13 x 30.55 mm 16g	<b>PRSXT 1/230V DC</b> <b>16085.2 / 1</b> 29 x 13 x 30.55 mm 16g				
Insulation IEC 664/VDE 0110, Rated voltage 250 V, contamination degree 3, Overvoltage category III, Flammability class UL 94 V-0					
2.5 KV	2.5 KV				
-40 to +70°C	-40 to +70°C				
yes	yes				
red LED	red LED				
yes	yes				
no	no				
24V AC	230V AC				
0.76VA	0.74VA				
50/60 Hz	50/60 Hz				
1 CO contact	1 CO contact				
240 V AC/400 V AC	240 V AC/400 V AC				
16 A, 240 V AC	16 A, 240 V AC				
30 A /300 A	30 A /300 A				
4000 VA	4000 VA				
12V at 10mA	12V at 10mA				
30mV at 100mA/6VDC	30mV at 100mA/6VDC				
360 Cycles per hour	360 Cycles per hour				
36000 Cycles per hour	36000 Cycles per hour				
8 ms/6 ms	8 ms/6 ms				
AgNi 90/10	AgNi 90/10				
50 x 10 <sup>3</sup>	50 x 10 <sup>3</sup>				
5 x 10 <sup>6</sup>	5 x 10 <sup>6</sup>				

<b>PRS 2 G</b> <b>15320.2 / 1</b>	<b>PRS 2 G</b> <b>15320.2 / 1</b>				
TS 35	TS 35				
5mm pinning	5mm pinning				
Screw connection	Screw connection				
10A	10A				
300 V	300 V				
4000 Veff	4000 Veff				
C/250 V	C/250 V				
-25... +80°C	-25... +80°C				
IP 20	IP 20				
V-0	V-0				
VBG 4	VBG 4				
2 x 2.5 mm <sup>2</sup>	2 x 2.5 mm <sup>2</sup>				
2 x 1.5 mm <sup>2</sup>	2 x 1.5 mm <sup>2</sup>				
max. 0.8 Nm	max. 0.8 Nm				
7 mm	7 mm				
UL/CSA	UL/CSA				

<b>PRSXT C1/2</b> <b>16016.2 / 20</b>	<b>PRSXT C1/2</b> <b>16016.2 / 20</b>				
--	--	--	--	--	--

## Relay 2-CO PRS 2 XT

Complete screw-connection units consisting of:	PRSUXT 2/24V DC	PRSUXT 2/24V AC	PRSUXT 2/230V	PRSUXT 2G/24V DC
<ul style="list-style-type: none"> <li>Relay</li> <li>Socket base</li> <li>Holding clamp</li> </ul>				
Type	PRSUXT 2/24V DC	PRSUXT 2/24V AC	PRSUXT 2/230V DC	PRSUXT 2G/24V DC
Cat. no./Qty.	16017.2 / 1	16018.2 / 1	16019.2 / 1	16020.2 / 1
Size (L x W x H) with TS 35 x 7.5	76 x 15.7 x 76 mm	76 x 15.7 x 76 mm	76 x 15.7 x 76 mm	76 x 15.7 x 76 mm
Weight	56g	56g	56g	56g

### Individual components Relay 2W, open design, with switch and status display



Type	PRSXT 2/24V DC	PRSXT 2/24V AC	PRSXT 2/230V DC	PRSXT 2/24V DC
Cat. no./Qty.	16013.2 / 1	16014.2 / 1	16015.2 / 1	16013.2 / 1
Dimensions (L x W x H)	29 x 13 x 30.55 mm	29 x 13 x 30.55 mm	29 x 13 x 30.55 mm	29 x 13 x 30.55 mm
Weight	16g	16g	16g	16g
Common data	Insulation IEC 664/VDE 0110, Rated voltage 250 V, contamination degree 3, Overvoltage category III, Flammability class UL 94 V-0			
DIN-VDE specifications	Insulation IEC 664/VDE 0110, Rated voltage 250 V, contamination degree 3, Overvoltage category III, Flammability class UL 94 V-0			
Test voltage coil/contact	2.5 KV	2.5 KV	2.5 KV	2.5 KV
Operating temperature	-40 to +70°C	-40 to +70°C	-40 to +70°C	-40 to +70°C
Lockable test button	yes	yes	yes	yes
Indicators	red LED	red LED	red LED	red LED
Mechanical indicator	yes	yes	yes	yes
Free-wheel diode	yes	no	no	yes
Input data				
Input voltage	24 V DC	24V AC	230V AC	24 V DC
Rated power consumption	0.4W	0.76VA	0.74VA	0.4W
Frequency	-	50/60 Hz	50/60 Hz	-
Output specifications				
Contacts	2 CO contact	2 CO contact	2 CO contact	2 CO contact
Switching voltage/Max. switching voltage	240 V AC/400 V AC	240 V AC/400 V AC	240 V AC/400 V AC	240 V AC/400 V AC
Max. continuous current	8 A, 240 V AC	8 A, 240 V AC	8 A, 240 V AC	8 A, 240 V AC
Max. inrush current 4s / 30 ms	15 A /300 A	15 A /300 A	15 A /300 A	15 A /300 A
Max. contact load	2000 VA	2000 VA	2000 VA	2000 VA
Min. suggested contact load	12V at 10mA	12V at 10mA	12V at 10mA	12V at 10mA
Voltage drop	30mV at 100mA/6VDC	30mV at 100mA/6VDC	30mV at 100mA/6VDC	30mV at 100mA/6VDC
Max. switching frequency at operating load	360 Cycles per hour	360 Cycles per hour	360 Cycles per hour	360 Cycles per hour
Max. switching frequency without load	36000 Cycles per hour	36000 Cycles per hour	36000 Cycles per hour	36000 Cycles per hour
Typical response time/release time	10 ms/5 ms	10 ms/5 ms	10 ms/5 ms	10 ms/5 ms
Contact material	AgNi 90/10	AgNi 90/10	AgNi 90/10	AgNi 90/10
Electrical service life	50 x 10 <sup>3</sup>	50 x 10 <sup>3</sup>	50 x 10 <sup>3</sup>	50 x 10 <sup>3</sup>
Mechanical service life	10 x 10 <sup>6</sup>	5 x 10 <sup>6</sup>	5 x 10 <sup>6</sup>	10 x 10 <sup>6</sup>

### Socket base

Type	PRS 2	PRS 2	PRS 2	PRS 2 G
Cat. no./Qty.	15136.2 / 1	15136.2 / 1	15136.2 / 1	15320.2 / 1
Overview				
Mounting foot for DIN rails	TS 35	TS 35	TS 35	TS 35
Plug-in base for	5mm pinning	5mm pinning	5mm pinning	5mm pinning
Connection type	Screw connection	Screw connection	Screw connection	Screw connection
Technical data				
Rated current	10A	10A	10A	10A
Rated voltage	300 V	300 V	300 V	300 V
Dielectric strength	4000 Veff	4000 Veff	4000 Veff	4000 Veff
Insulation group (VDE 0110b)	C/250 V	C/250 V	C/250 V	C/250 V
Ambient temperature	-25... +80°C	-25... +80°C	-25... +80°C	-25... +80°C
Protection degree, enclosure	IP 20	IP 20	IP 20	IP 20
Flammability class UL 94	V-0	V-0	V-0	V-0
Touch protection, acc. to	VBG 4	VBG 4	VBG 4	VBG 4
Connection cross-section	2 x 2.5 mm <sup>2</sup>	2 x 2.5 mm <sup>2</sup>	2 x 2.5 mm <sup>2</sup>	2 x 2.5 mm <sup>2</sup>
With ferrules	2 x 1.5 mm <sup>2</sup>	2 x 1.5 mm <sup>2</sup>	2 x 1.5 mm <sup>2</sup>	2 x 1.5 mm <sup>2</sup>
Screw torque	max. 0.8 Nm	max. 0.8 Nm	max. 0.8 Nm	max. 0.8 Nm
Stripping length	7 mm	7 mm	7 mm	7 mm
Approvals	UL/CSA	UL/CSA	UL/CSA	UL/CSA

### Holding clamp

Type	PRSXT C1/2	PRSXT C1/2	PRSXT C1/2	PRSXT C1/2
Cat. no./Qty.	16016.2 / 20	16016.2 / 20	16016.2 / 20	16016.2 / 20

<b>PRSUXT 2G/24V AC</b>	<b>PRSUXT 2G/230V AC</b>				
					
<b>PRSUXT 2G/24V AC</b> <b>16021.2 / 1</b> 76 x 15.7 x 76 mm 56g	<b>PRSUXT 2G/230V AC</b> <b>16022.2 / 1</b> 76 x 15.7 x 76 mm 56g				

<b>PRSXT 2/24V AC</b> <b>16014.2 / 1</b> 29 x 13 x 30.55 mm 16g	<b>PRSXT 2/230V DC</b> <b>16015.2 / 1</b> 29 x 13 x 30.55 mm 16g				
Insulation IEC 664/VDE 0110, Rated voltage 250 V, contamination degree 3, Overvoltage category III, Flammability class UL 94 V-0					
2.5 KV	2.5 KV				
-40 to +70°C	-40 to +70°C				
yes	yes				
red LED	red LED				
yes	yes				
no	no				
24V AC	230V AC				
0.76VA	0.74VA				
50/60 Hz	50/60 Hz				
2 CO contact	2 CO contact				
240 V AC/400 V AC	240 V AC/400 V AC				
8 A, 240 V AC	8 A, 240 V AC				
15 A /300 A	15 A /300 A				
2000 VA	2000 VA				
12V at 10mA	12V at 10mA				
30mV at 100mA/6VDC	30mV at 100mA/6VDC				
360 Cycles per hour	360 Cycles per hour				
36000 Cycles per hour	36000 Cycles per hour				
10 ms/5 ms	10 ms/5 ms				
AgNi 90/10	AgNi 90/10				
50 x 10 <sup>3</sup>	50 x 10 <sup>3</sup>				
5 x 10 <sup>6</sup>	5 x 10 <sup>6</sup>				

<b>PRS 2 G</b> <b>15320.2 / 1</b>	<b>PRS 2 G</b> <b>15320.2 / 1</b>				
TS 35	TS 35				
5mm pinning	5mm pinning				
Screw connection	Screw connection				
10A	10A				
300 V	300 V				
4000 Veff	4000 Veff				
C/250 V	C/250 V				
-25... +80°C	-25... +80°C				
IP 20	IP 20				
V-0	V-0				
VBG 4	VBG 4				
2 x 2.5 mm <sup>2</sup>	2 x 2.5 mm <sup>2</sup>				
2 x 1.5 mm <sup>2</sup>	2 x 1.5 mm <sup>2</sup>				
max. 0.8 Nm	max. 0.8 Nm				
7 mm	7 mm				
UL/CSA	UL/CSA				

<b>PRSXT C1/2</b> <b>16016.2 / 20</b>	<b>PRSXT C1/2</b> <b>16016.2 / 20</b>				
--	--	--	--	--	--

## Relay with 1 CO PRS 1

Complete screw-connection components	PRSU 1/12 V DC	PRSU 1/24 V DC	PRSU 1/60 V DC	PRSU 1/110 V DC
consisting of:				
· Relay				
· Insert module				
· Socket base				
· Holding clamp				
<b>Type</b>	<b>PRSU 1/12 V DC</b>	<b>PRSU 1/24 V DC</b>	<b>PRSU 1/60 V DC</b>	<b>PRSU 1/110 V DC</b>
<b>Cat. no./Qty.</b>	<b>15163.2/1</b>	<b>15169.2/1</b>	<b>15720.2/1</b>	<b>15721.2/1</b>
Size (L x W x H) with TS 35 x 7.5	76 x 15.7 x 71 mm	76 x 15.7 x 71 mm	76 x 15.7 x 71 mm	76 x 15.7 x 71 mm
Weight	55 g	55 g	55 g	55 g

### Individual components

#### Relay 1 W, encapsulated design

Type	PRS 1/12 V DC	PRS 1/24 V DC	PRS 1/60 V DC	PRS 1/110 V DC
<b>Cat. no./Qty.</b>	<b>6996.0/1</b>	<b>6804.0/1</b>	<b>15539.2/1</b>	<b>15540.2/1</b>
Weight	15 g	15 g	15 g	15 g
<b>General information</b>	Insulation IEC 664/VDE 0110, rated voltage 250 V, pollution degree 3, overvoltage category III, flammability class UL 94 V-0			
DIN-VDE specifications	Insulation IEC 664/VDE 0110, rated voltage 250 V, pollution degree 3, overvoltage category III, flammability class UL 94 V-0			
Test voltage coil/contact	5 kV	5 kV	5 kV	5 kV
Pinning	3.5mm	3.5mm	3.5mm	3.5mm
Operating temperature	-40 to +85°C	-40 to +85°C	-40 to +85°C	-40 to +85°C
Important Notes	-	-	-	-
<b>Input data</b>				
Input voltage	12 V DC	24 V DC	60 V DC	110 V DC
Rated power consumption	0.40 W	0.40 W	0.42 W	0.42 W
<b>Output data</b>				
Contacts	1 CO contact	1 CO contact	1 CO contact	1 CO contact
Switching voltage/Max. switching voltage	250 V AC/440 V AC	250 V AC/440 V AC	250 V AC/440 V AC	250 V AC/440 V AC
Max continuous current/inrush current	12 A/25 A	12 A/25 A	12 A/25 A	12 A/25 A
Typical response time/release time	7 ms/3 ms	7 ms/3 ms	7 ms/3 ms	7 ms/3 ms
Contact material	AgNi 90/10	AgNi 90/10	AgNi 90/10	AgNi 90/10
Electrical service life	1.2 x 10 <sup>3</sup>	1.2 x 10 <sup>3</sup>	1.2 x 10 <sup>3</sup>	1.2 x 10 <sup>3</sup>
at contact load	4 A, 250 V AC	4 A, 250 V AC	4 A, 250 V AC	4 A, 250 V AC
Mechanical life span	> 30 x 10 <sup>6</sup>	> 30 x 10 <sup>6</sup>	> 30 x 10 <sup>6</sup>	> 30 x 10 <sup>6</sup>

### Insert module

Type	PRS LED 24 V DC	PRS LED 24 V DC	PRS LED 110 V DC	PRS LED 110 V DC
<b>Cat. no./Qty.</b>	<b>15141.2/1</b>	<b>15141.2/1</b>	<b>15422.2/1</b>	<b>15422.2/1</b>
protected against polarity reversal in parallel to coil	Status display with free-wheel diode 12 to 24 V DC	Status display with free-wheel diode 12 to 24 V DC	Status display with free-wheel diode 60 to 110 V DC	Status display with free-wheel diode 60 to 110 V DC

### Socket base

Type	PRS 1	PRS 1	PRS 1	PRS 1
<b>Cat. no./Qty.</b>	<b>15135.2/1</b>	<b>15135.2/1</b>	<b>15135.2/1</b>	<b>15135.2/1</b>
<b>General</b>				
Mounting foot for DIN rails	TS 35	TS 35	TS 35	TS 35
Plug-in modules for	3.5 mm pinning	3.5 mm pinning	3.5 mm pinning	3.5 mm pinning
Connection type	Screw connection	Screw connection	Screw connection	Screw connection
<b>Technical data</b>				
Rated current	12 A	12 A	12 A	12 A
Rated voltage	300 V	300 V	300 V	300 V
Dielectric strength	4000 Veff	4000 Veff	4000 Veff	4000 Veff
Insulation group (VDE 0110 b)	C/250 V	C/250 V	C/250 V	C/250 V
Ambient temperature	-25 to +80°C	-25 to +80°C	-25 to +80°C	-25 to +80°C
Protection degree, enclosure	IP 20	IP 20	IP 20	IP 20
Flammability class UL 94	V-0	V-0	V-0	V-0
Touch protection, acc. to	VBG 4	VBG 4	VBG 4	VBG 4
Connection cross-section	2 x 2.5 mm <sup>2</sup>	2 x 2.5 mm <sup>2</sup>	2 x 2.5 mm <sup>2</sup>	2 x 2.5 mm <sup>2</sup>
With ferrules	2 x 1.5 mm <sup>2</sup>	2 x 1.5 mm <sup>2</sup>	2 x 1.5 mm <sup>2</sup>	2 x 1.5 mm <sup>2</sup>
Screw torque	max. 0.8 Nm	max. 0.8 Nm	max. 0.8 Nm	max. 0.8 Nm
Approvals	UL/CSA	UL/CSA	UL/CSA	UL/CSA

### Holding clamp

Type	PRS C 1/2	PRS C 1/2	PRS C 1/2	PRS C 1/2
<b>Cat. no./Qty.</b>	<b>15138.2/1</b>	<b>15138.2/1</b>	<b>15138.2/1</b>	<b>15138.2/1</b>

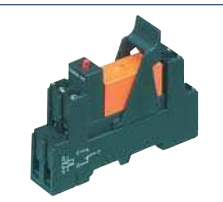
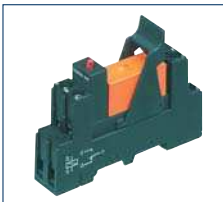
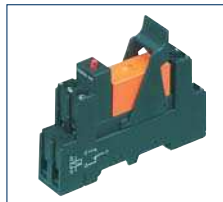
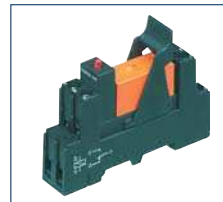
PRSU 1 L/24 V DC	PRSU 1/24 V AC	PRSU 1/115 V AC	PRSU 1/230 V AC		
					
<b>PRSU 1 L/24 V DC 15419.2/1</b>	<b>PRSU 1/24 V AC 15164.2/1</b>	<b>PRSU 1/115 V AC 15418.2/1</b>	<b>PRSU 1/230 V AC 15170.2/1</b>		
76 x 15.7 x 71 mm 60 g	76 x 15.7 x 71 mm 55 g	76 x 15.7 x 71 mm 55 g	76 x 15.7 x 71 mm 55 g		

PRS 1 L/24 V DC 6940.0/1	PRS 1/24 V AC 6480.2/1	PRS 1/115 V AC 15228.2/1	PRS 1/230 V AC 6481.2/1		
15 g	15 g	15 g	15 g		

Insulation IEC 664/VDE 0110, rated voltage 250 V, pollution degree 3, overvoltage category III, flammability class UL 94 V-0					
4 kV	5 kV	5 kV	5 kV		
5 mm	3.5 mm	3.5 mm	3.5 mm		
-20 to +50°C	-40 to +70°C	-40 to +70°C	-40 to +70°C		
Inductive loads	-	-	-		
24 V DC	24 V AC	115 V AC	230 V AC		
0.50 W	0.75 VA	0.75 VA	0.75 VA		
1 CO contact	1 CO contact	1 CO contact	1 CO contact		
250 V AC	250 V AC/440 V AC	250 V AC/440 V AC	250 V AC/440 V AC		
16 A/80 A (20 ms)	12 A/25 A	12 A/25 A	12 A/25 A		
10 ms/10 ms	7 ms/3 ms	7 ms/3 ms	7 ms/3 ms		
Ag Sn 02	AgNi 90/10	AgNi 90/10	AgNi 90/10		
1 x 10 <sup>5</sup>	1.2 x 10 <sup>3</sup>	1.2 x 10 <sup>3</sup>	1.2 x 10 <sup>3</sup>		
16 A, 250 V AC	4 A, 250 V AC	4 A, 250 V AC	4 A, 250 V AC		
> 30 x 10 <sup>6</sup>	> 30 x 10 <sup>6</sup>	> 30 x 10 <sup>6</sup>	> 30 x 10 <sup>6</sup>		

PRS LED 24 V DC 15141.2/1	PRS LED 24 V UC 15175.2/1	PRS LED 230 V AC 15142.2/1	PRS LED 230 V AC 15142.2/1		
Status display with free-wheel diode 12 to 24 V DC	Status display 12 to 48 V AC/DC	Status display 110 to 230 V/AC	Status display 110 to 230 V/AC		

PRS 2 15136.2/1	PRS 1 15135.2/1	PRS 1 15135.2/1	PRS 1 15135.2/1		
TS 35	TS 35	TS 35	TS 35		
5 mm pinning	3.5 mm pinning	3.5 mm pinning	3.5 mm pinning		
Screw connection	Screw connection	Screw connection	Screw connection		
10 A	12 A	12 A	12 A		
300 V	300 V	300 V	300 V		
4000 Veff	4000 Veff	4000 Veff	4000 Veff		
C/250 V	C/250 V	C/250 V	C/250 V		
-25 to +80°C	-25 to +80°C	-25 to +80°C	-25 to +80°C		
IP 20	IP 20	IP 20	IP 20		
V-0	V-0	V-0	V-0		
VBG 4	VBG 4	VBG 4	VBG 4		
2 x 2.5 mm <sup>2</sup>	2 x 2.5 mm <sup>2</sup>	2 x 2.5 mm <sup>2</sup>	2 x 2.5 mm <sup>2</sup>		
2 x 1.5 mm <sup>2</sup>	2 x 1.5 mm <sup>2</sup>	2 x 1.5 mm <sup>2</sup>	2 x 1.5 mm <sup>2</sup>		
max. 0.8 Nm	max. 0.8 Nm	max. 0.8 Nm	max. 0.8 Nm		
UL/CSA	UL/CSA	UL/CSA	UL/CSA		

PRS C 1/2 15138.2/1	PRS C 1/2 15138.2/1	PRS C 1/2 15138.2/1	PRS C 1/2 15138.2/1		
------------------------	------------------------	------------------------	------------------------	--	--

## Relay with 2 CO PRS 2

Complete screw-connection components	PRSU 2/12 V DC	PRSU 2/24 V DC	PRSU 2/48 V DC	PRSU 2/60 V DC
consisting of:				
· Relay				
· Insert module				
· Socket base				
· Holding clamp				
<b>Type</b>	<b>PRSU 2/12 V DC</b>	<b>PRSU 2/24 V DC</b>	<b>PRSU 2/48 V DC</b>	<b>PRSU 2/60 V DC</b>
<b>Cat. no./Qty.</b>	<b>15165.2/1</b>	<b>15171.2/1</b>	<b>15411.2/1</b>	<b>15412.2/1</b>
Size (L x W x H) with TS 35 x 7.5	76 x 15.7 x 71 mm	76 x 15.7 x 71 mm	76 x 15.7 x 71 mm	76 x 15.7 x 71 mm
Weight	60 g	60 g	60 g	60 g

### Individual components

#### Relay 2 W, encapsulated design

Type	PRS 2/12 V DC	PRS 2/24 V DC	PRS 2/48 V DC	PRS 2/60 V DC
<b>Cat. no./Qty.</b>	<b>6482.2/1</b>	<b>6483.2/1</b>	<b>15334.2/1</b>	<b>15335.2/1</b>
Weight	15 g	15 g	15 g	15 g
<b>General information</b>	Insulation IEC 664/VDE 0110, rated voltage 250 V, pollution degree 3, overvoltage category III, flammability class UL 94 V-0			
DIN-VDE specifications	Insulation IEC 664/VDE 0110, rated voltage 250 V, pollution degree 3, overvoltage category III, flammability class UL 94 V-0			
Test voltage coil/contact	5 kV	5 kV	5 kV	5 kV
Pinning	5 mm	5 mm	5 mm	5 mm
Operating temperature	-40 to +70°C	-40 to +70°C	-40 to +70°C	-40 to +70°C
<b>Input data</b>				
Input voltage	12 V DC	24 V DC	48 V DC	60 V DC
Rated power consumption	0.40 W	0.40 W	0.40 W	0.40 W
<b>Output data</b>				
Contacts	2 CO contact	2 CO contact	2 CO contact	2 CO contact
Switching voltage/Max. switching voltage	250 V AC/440 V AC	250 V AC/440 V AC	250 V AC/440 V AC	250 V AC/440 V AC
Max continuous current/inrush current	8 A/15 A	8 A/15 A	12 A/25 A	8 A/15 A
Typical response time/release time	7 ms/2 ms	7 ms/2 ms	7 ms/2 ms	7 ms/2 ms
Contact material	AgNi 90/10	AgNi 90/10	AgNi 90/10	AgNi 90/10
Electrical service life	1.5 x 10 <sup>5</sup>	1.5 x 10 <sup>5</sup>	1.5 x 10 <sup>5</sup>	1.5 x 10 <sup>5</sup>
at contact load	4 A, 230 V AC	4 A, 230 V AC	4 A, 230 V AC	4 A, 230 V AC
Mechanical life span	> 30 x 10 <sup>6</sup>	> 30 x 10 <sup>6</sup>	> 30 x 10 <sup>6</sup>	> 30 x 10 <sup>6</sup>

### Insert module



Type	PRS LED 24 V DC	PRS LED 24 V DC	PRS LED 24 V UC	PRS LED 110 V DC
<b>Cat. no./Qty.</b>	<b>15141.2/1</b>	<b>15141.2/1</b>	<b>15175.2/1</b>	<b>15422.2/1</b>
protected against polarity reversal in parallel to coil	Status display with free-wheel diode 12 to 24 V DC	Status display with free-wheel diode 12 to 24 V DC	Status display 12 to 48 V AC/DC	Status display with free-wheel diode 60 to 110 V DC

### Socket base

Type	PRS 2	PRS 2	PRS 2	PRS 2
<b>Cat. no./Qty.</b>	<b>15136.2/1</b>	<b>15136.2/1</b>	<b>15136.2/1</b>	<b>15136.2/1</b>
<b>General</b>				
Mounting foot for DIN rails	TS 35	TS 35	TS 35	TS 35
Plug-in modules for	5 mm pinning	5 mm pinning	5 mm pinning	5 mm pinning
Connection type	Screw connection	Screw connection	Screw connection	Screw connection
<b>Technical data</b>				
Rated current	10 A	10 A	10 A	10 A
Rated voltage	300 V	300 V	300 V	300 V
Dielectric strength	4000 Veff	4000 Veff	4000 Veff	4000 Veff
Insulation group (VDE 0110 b)	C/250 V	C/250 V	C/250 V	C/250 V
Ambient temperature	-25 to +80°C	-25 to +80°C	-25 to +80°C	-25 to +80°C
Protection degree, enclosure	IP 20	IP 20	IP 20	IP 20
Flammability class UL 94	V-0	V-0	V-0	V-0
Touch protection, acc. to	VBG 4	VBG 4	VBG 4	VBG 4
Connection cross-section	2 x 2.5 mm <sup>2</sup>	2 x 2.5 mm <sup>2</sup>	2 x 2.5 mm <sup>2</sup>	2 x 2.5 mm <sup>2</sup>
With ferrules	2 x 1.5 mm <sup>2</sup>	2 x 1.5 mm <sup>2</sup>	2 x 1.5 mm <sup>2</sup>	2 x 1.5 mm <sup>2</sup>
Screw torque	max. 0.8 Nm	max. 0.8 Nm	max. 0.8 Nm	max. 0.8 Nm
Approvals	UL/CSA	UL/CSA	UL/CSA	UL/CSA

### Holding clamp

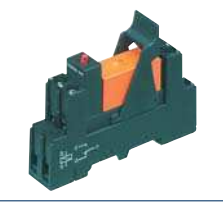
Type	PRS C 1/2	PRS C 1/2	PRS C 1/2	PRS C 1/2
<b>Cat. no./Qty.</b>	<b>15138.2/1</b>	<b>15138.2/1</b>	<b>15138.2/1</b>	<b>15138.2/1</b>

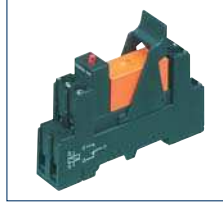
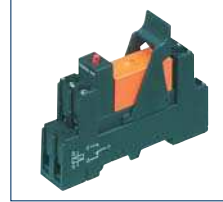
PRSU 2/110 V DC	PRSU 2/24 V AC	PRSU 2/115 V AC	PRSU 2/230 V AC		
					
<b>PRSU 2/110 V DC 15722.2/1</b>	<b>PRSU 2/24 V AC 15166.2/1</b>	<b>PRSU 2/115 V AC 15413.2/1</b>	<b>PRSU 2/230 V AC 15172.2/1</b>		
76 x 15.7 x 71 mm 60 g	76 x 15.7 x 71 mm 60 g	76 x 15.7 x 71 mm 60 g	76 x 15.7 x 71 mm 60 g		

PRS 2/110 V DC 15541.2/1	PRS 2/24 V AC 6484.2 /1	PRS 2/115 V AC 15229.2/1	PRS 2/230 V AC 6485.2/1		
15 g	15 g	15 g	15 g		

Insulation IEC 664/VDE 0110, rated voltage 250 V, pollution degree 3, overvoltage category III, flammability class UL 94 V-0

5 kV	5 kV	5 kV	5 kV		
5 mm	5 mm	5 mm	5 mm		
-40 to +70°C	-40 to +70°C	-40 to +70°C	-40 to +70°C		
110 V DC 0.40 W	24 V AC 0.75 VA	115 V AC 0.75 VA	230 V AC 0.75 VA		
2 CO contact 250 V AC/440 V AC 8 A/15 A 7 ms/2 ms AgNi 90/10 1.5 x 10 <sup>5</sup> 4 A, 230 V AC > 30 x 10 <sup>6</sup>	2 CO contact 250 V AC/440 V AC 8 A/15 A 7 ms/2 ms AgNi 90/10 1.5 x 10 <sup>5</sup> 4 A, 230 V AC > 5 x 10 <sup>6</sup>	2 CO contact 250 V AC/440 V AC 8 A/15 A 7 ms/2 ms AgNi 90/10 1.5 x 10 <sup>5</sup> 4 A, 230 V AC > 5 x 10 <sup>6</sup>	2 CO contact 250 V AC/440 V AC 8 A/15 A 7 ms/2 ms AgNi 90/10 1.5 x 10 <sup>5</sup> 4 A, 230 V AC > 5 x 10 <sup>6</sup>		

PRS LED 110 V DC 15422.2 /1	PRS LED 24 V UC 15175.2/1	PRS LED 230 V AC 15142.2/1	PRS LED 230 V AC 15142.2/1		
Status display with free-wheel diode 60 to 110 V DC	Status display 12 to 48 V AC/DC	Status display 110 to 230 V AC/DC	Status display 110 to 230 V AC/DC		

PRS 2 15136.2/1	PRS 2 15136.2/1	PRS 2 15136.2/1	PRS 2 15136.2/1		
TS 35	TS 35	TS 35	TS 35		
5 mm pinning	5 mm pinning	5 mm pinning	5 mm pinning		
Screw connection	Screw connection	Screw connection	Screw connection		
10 A	10 A	10 A	10 A		
300 V	300 V	300 V	300 V		
4000 Veff	4000 Veff	4000 Veff	4000 Veff		
C/250 V	C/250 V	C/250 V	C/250 V		
-25 to +80°C	-25 to +80°C	-25 to +80°C	-25 to +80°C		
IP 20	IP 20	IP 20	IP 20		
V-0	V-0	V-0	V-0		
VBG 4	VBG 4	VBG 4	VBG 4		
2 x 2.5 mm <sup>2</sup>	2 x 2.5 mm <sup>2</sup>	2 x 2.5 mm <sup>2</sup>	2 x 2.5 mm <sup>2</sup>		
2 x 1.5 mm <sup>2</sup>	2 x 1.5 mm <sup>2</sup>	2 x 1.5 mm <sup>2</sup>	2 x 1.5 mm <sup>2</sup>		
max. 0.8 Nm	max. 0.8 Nm	max. 0.8 Nm	max. 0.8 Nm		
UL/CSA	UL/CSA	UL/CSA	UL/CSA		

PRS C 1/2 15138.2/1	PRS C 1/2 15138.2/1	PRS C 1/2 15138.2/1	PRS C 1/2 15138.2/1		
------------------------	------------------------	------------------------	------------------------	--	--

## Relay 2 CO contact, PRS 2 G

### Complete screw-connection components

consisting of:

- Relay
- Insert module
- Socket base
- Holding clamp

#### PRS 2 G/12 V DC



#### PRS 2 G/24 V DC



#### PRS 2 G/48 V DC



#### PRS 2 G/60 V DC



Type	PRS 2 G/12 V DC	PRS 2 G/24 V DC	PRS 2 G/48 V DC	PRS 2 G/60 V DC
Cat. no./Qty.	15414.2/1	15233.2/1	15415.2/1	15416.2/1
Size (L x W x H) with TS 35	76 x 15.7 x 71 mm	76 x 15.7 x 71 mm	76 x 15.7 x 71 mm	76 x 15.7 x 71 mm
Weight	60 g	60 g	60 g	60 g

### Individual components

#### Relay 2 W, encapsulated design

Type	PRS 2/12 V DC	PRS 2/24 V DC	PRS 2/48 V DC	PRS 2/60 V DC
Cat. no./Qty.	6482.2/1	6483.2/1	15334.2/1	15335.2/1
Weight	15 g	15 g	15 g	15 g
<b>General information</b>	Insulation IEC 664/VDE 0110, rated voltage 250 V, pollution degree 3, overvoltage category III, flammability class UL 94 V-0			
DIN-VDE specifications	Insulation IEC 664/VDE 0110, rated voltage 250 V, pollution degree 3, overvoltage category III, flammability class UL 94 V-0			
Test voltage coil/contact	5 kV	5 kV	5 kV	5 kV
Pinning	5 mm	5 mm	5 mm	5 mm
Operating temperature	-40 to +70°C	-40 to +70°C	-40 to +70°C	-40 to +70°C
<b>Input data</b>				
Input voltage	12 V DC	24 V DC	48 V DC	60 V DC
Rated power consumption	0.40 W	0.40 W	0.40 W	0.40 W
<b>Output data</b>				
Contacts	2 CO contact	2 CO contact	2 CO contact	2 CO contact
Switching voltage/Max. switching voltage	250 V AC/440 V AC	250 V AC/440 V AC	250 V AC/440 V AC	250 V AC/440 V AC
Max continuous current/inrush current	8 A/15 A	8 A/15 A	8 A/15 A	8 A/15 A
Typical response time/release time	7 ms/2 ms	7 ms/2 ms	7 ms/2 ms	7 ms/2 ms
Contact material	AgNi 90/10	AgNi 90/10	AgNi 90/10	AgNi 90/10
Electrical service life	1.5 x 10 <sup>5</sup>	1.5 x 10 <sup>5</sup>	1.5 x 10 <sup>5</sup>	1.5 x 10 <sup>5</sup>
at contact load	4 A, 230 V AC	4 A, 230 V AC	4 A, 230 V AC	4 A, 230 V AC
Mechanical life span	> 30 x 10 <sup>6</sup>	> 30 x 10 <sup>6</sup>	> 30 x 10 <sup>6</sup>	> 30 x 10 <sup>6</sup>

### Insert module





Type	PRS LED 24 V DC	PRS LED 24 V DC	PRS LED 24 V UC	PRS LED 110 V DC
Cat. no./Qty.	15141.2/1	15141.2/1	15175.2/1	15422.2/1
protected against polarity reversal in parallel to coil	Status display with free-wheel diode 12 to 24 V DC	Status display with free-wheel diode 12 to 24 V DC	Status display 12 to 48 V AC/DC	Status display with free-wheel diode 60 to 110 V DC

### Socket base

Type	PRS 2 G	PRS 2 G	PRS 2 G	PRS 2 G
Cat. no./Qty.	15320.2/1	15320.2/1	15320.2/1	15320.2/1
<b>General</b>				
Mounting foot for DIN rails	TS 35	TS 35	TS 35	TS 35
Plug-in modules for	5 mm pinning	5 mm pinning	5 mm pinning	5 mm pinning
Connection type	Screw connection	Screw connection	Screw connection	Screw connection
<b>Technical data</b>				
Rated current	10 A	10 A	10 A	10 A
Rated voltage	300 V	300 V	300 V	300 V
Dielectric strength	4000 Veff	4000 Veff	4000 Veff	4000 Veff
Insulation group (VDE 0110 b)	C/250 V	C/250 V	C/250 V	C/250 V
Ambient temperature	-25 to +80°C	-25 to +80°C	-25 to +80°C	-25 to +80°C
Protection degree, enclosure	IP 20	IP 20	IP 20	IP 20
Flammability class UL 94	V-0	V-0	V-0	V-0
Touch protection, acc. to	VBG 4	VBG 4	VBG 4	VBG 4
Connection cross-section	2 x 2.5 mm <sup>2</sup>	2 x 2.5 mm <sup>2</sup>	2 x 2.5 mm <sup>2</sup>	2 x 2.5 mm <sup>2</sup>
With ferrules	2 x 1.5 mm <sup>2</sup>	2 x 1.5 mm <sup>2</sup>	2 x 1.5 mm <sup>2</sup>	2 x 1.5 mm <sup>2</sup>
Screw torque	max. 0.8 Nm	max. 0.8 Nm	max. 0.8 Nm	max. 0.8 Nm
Approvals	UL/CSA	UL/CSA	UL/CSA	UL/CSA

### Holding clamp

Type	PRS C 1/2	PRS C 1/2	PRS C 1/2	PRS C 1/2
Cat. no./Qty.	15138.2/1	15138.2/1	15138.2/1	15138.2/1

<b>PRSU 2 G/110 V DC</b>	<b>PRSU 2 G/24 V AC</b>	<b>PRSU 2 G/115 V AC</b>	<b>PRSU 2 G/230 V AC</b>		
					
<b>PRSU 2 G/110 V DC 15723.2/1</b>	<b>PRSU 2 G/24 V AC 15385.2/1</b>	<b>PRSU 2 G/115 V AC 15417.2/1</b>	<b>PRSU 2 G/230 V AC 15236.2/1</b>		
76 x 15.7 x 71 mm 60 g	76 x 15.7 x 71 mm 60 g	76 x 15.7 x 71 mm 60 g	76 x 15.7 x 71 mm 60 g		

<b>PRS 2/110 V DC 15541.2/1</b>	<b>PRS 2/24 V AC 6484.2/1</b>	<b>PRS 2/115 V AC 15229.2/1</b>	<b>PRS 2/230 V AC 6485.2/1</b>		
15 g	15 g	15 g	15 g		

Insulation IEC 664/VDE 0110, rated voltage 250 V, pollution degree 3, overvoltage category III, flammability class UL 94 V-0

5 kV	5 kV	5 kV	5 kV		
5 mm	5 mm	5 mm	5 mm		
-40 to +70°C	-40 to +70°C	-40 to +70°C	-40 to +70°C		
110 V DC 0.40 W	24 V DC 0.75 VA	115 V DC 0.75 VA	230 V AC 0.75 VA		
2 CO contact 250 V AC/440 V AC 8 A/15 A 7 ms/2 ms AgNi 90/10 1.5 x 10 <sup>5</sup> 4 A, 230 V AC > 30 x 10 <sup>6</sup>	2 CO contact 250 V AC/440 V AC 8 A/15 A 7 ms/2 ms AgNi 90/10 1.5 x 10 <sup>5</sup> 4 A, 230 V AC > 5 x 10 <sup>6</sup>	2 CO contact 250 V AC/440 V AC 8 A/15 A 7 ms/2 ms AgNi 90/10 1.5 x 10 <sup>5</sup> 4 A, 230 V AC > 5 x 10 <sup>6</sup>	2 CO contact 250 V AC/440 V AC 8 A/15 A 7 ms/2 ms AgNi 90/10 1.5 x 10 <sup>5</sup> 4 A, 230 V AC > 5 x 10 <sup>6</sup>		

<b>PRS LED 110 V DC 15422.2/1</b>	<b>PRS LED 24 V UC 15175.2/1</b>	<b>PRS LED 230 V AC 15142.2/1</b>	<b>PRS LED 230 V AC 15142.2/1</b>		
Status display with free-wheel diode 60 to 110 V DC	Status display 12 to 48 V AC/DC	Status display 110 to 230 V AC	Status display 110 to 230 V AC		

<b>PRS 2 G 15320.2/1</b>	<b>PRS 2 G 15320.2/1</b>	<b>PRS 2 G 15320.2/1</b>	<b>PRS 2 G 15320.2/1</b>		
TS 35	TS 35	TS 35	TS 35		
5 mm pinning	5 mm pinning	5 mm pinning	5 mm pinning		
Screw connection	Screw connection	Screw connection	Screw connection		
10 A	10 A	10 A	10 A		
300 V	300 V	300 V	300 V		
4000 Veff	4000 Veff	4000 Veff	4000 Veff		
C/250 V	C/250 V	C/250 V	C/250 V		
-25 to +80°C	-25 to +80°C	-25 to +80°C	-25 to +80°C		
IP 20	IP 20	IP 20	IP 20		
V-0	V-0	V-0	V-0		
VBG 4	VBG 4	VBG 4	VBG 4		
2 x 2.5 mm <sup>2</sup>	2 x 2.5 mm <sup>2</sup>	2 x 2.5 mm <sup>2</sup>	2 x 2.5 mm <sup>2</sup>		
2 x 1.5 mm <sup>2</sup>	2 x 1.5 mm <sup>2</sup>	2 x 1.5 mm <sup>2</sup>	2 x 1.5 mm <sup>2</sup>		
max. 0.8 Nm	max. 0.8 Nm	max. 0.8 Nm	max. 0.8 Nm		
UL/CSA	UL/CSA	UL/CSA	UL/CSA		

<b>PRS C 1/2 15138.2/1</b>	<b>PRS C 1/2 15138.2/1</b>	<b>PRS C 1/2 15138.2/1</b>	<b>PRS C 1/2 15138.2/1</b>		
--------------------------------	--------------------------------	--------------------------------	--------------------------------	--	--

## Relay with 4 CO PRS 4

Complete screw-connection components	PRSU 4/12 V DC	PRSU 4/24 V DC	PRSU 4/48 V DC	PRSU 4/60 V DC
consisting of:				
· Relay				
· Insert module				
· Socket base				
· Holding clamp				
<b>Type</b>	<b>PRSU 4/12 V DC</b>	<b>PRSU 4/24 V DC</b>	<b>PRSU 4/48 V DC</b>	<b>PRSU 4/60 V DC</b>
<b>Cat. no./Qty.</b>	<b>15167.2/1</b>	<b>15173.2/1</b>	<b>15724.2/1</b>	<b>15725.2/1</b>
Size (L x W x H) with TS 35 x 7.5	76 x 27.1 x 85 mm	76 x 27.1 x 85 mm	76 x 27.1 x 85 mm	76 x 27.1 x 85 mm
Weight	95 g	95 g	95 g	95 g

### Individual components

#### Relay 4 W, open design, with switch

Type	PRS 4/12 V DC	PRS 4/24 V DC	PRS 4/48 V DC	PRS 4/60 V DC
<b>Cat. no./Qty.</b>	<b>6486.2/1</b>	<b>6487.2/1</b>	<b>15461.2/1</b>	<b>15336.2/1</b>
Weight	30 g	30 g	30 g	30 g
<b>General information</b>	Insulation IEC 664/VDE 0110, rated voltage 250 V, pollution degree 3, overvoltage category III			
DIN-VDE specifications	Insulation IEC 664/VDE 0110, rated voltage 250 V, pollution degree 3, overvoltage category III			
Test voltage coil/contact	2.5 kV	2.5 kV	2.5 kV	2.5 kV
Operating temperature	-40 to +70°C	-40 to +70°C	-40 to +70°C	-40 to +70°C
<b>Input data</b>				
Input voltage	12 V DC	24 V DC	48 V DC	60 V DC
Rated power consumption	0.75 W	0.75 W	0.75 W	0.75 W
<b>Output data</b>				
Contacts	4 CO contact	4 CO contact	4 CO contact	4 CO contact
Switching voltage/Max. switching voltage	250 V AC/250 V AC	250 V AC/250 V AC	250 V AC/250 V AC	250 V AC/250 V AC
Max continuous current/inrush current	6 A/12 A	6 A/12 A	6 A/12 A	6 A/12 A
Typical response time/release time	15 ms/10 ms	15 ms/10 ms	15 ms/10 ms	15 ms/10 ms
Contact material	AgNi 90/10	AgNi 90/10	AgNi 90/10	AgNi 90/10
Electrical service life	1.5 x 10 <sup>5</sup>	1.5 x 10 <sup>5</sup>	1.5 x 10 <sup>5</sup>	1.5 x 10 <sup>5</sup>
at contact load	6 A, 250 V AC	6 A, 250 V AC	6 A, 250 V AC	6 A, 250 V AC
Mechanical life span	> 30 x 10 <sup>6</sup>	> 30 x 10 <sup>6</sup>	> 30 x 10 <sup>6</sup>	> 30 x 10 <sup>6</sup>

Insert module	PRS LED 24 V DC	PRS LED 24 V DC	PRS LED 24 V UC	PRS LED 110 V DC
<b>Type</b>	<b>PRS LED 24 V DC</b>	<b>PRS LED 24 V DC</b>	<b>PRS LED 24 V UC</b>	<b>PRS LED 110 V DC</b>
<b>Cat. no./Qty.</b>	<b>15141.2/1</b>	<b>15141.2/1</b>	<b>15175.2/1</b>	<b>15422.2/1</b>
protected against polarity reversal in parallel to coil	Status display with free-wheel diode	Status display with free-wheel diode	Status display	Status display with free-wheel diode
	12 to 24 V DC	12 to 24 V DC	12 to 48 V AC/DC	60 to 110 V DC

Socket base	PRS 4	PRS 4	PRS 4	PRS 4
<b>Type</b>	<b>PRS 4</b>	<b>PRS 4</b>	<b>PRS 4</b>	<b>PRS 4</b>
<b>Cat. no./Qty.</b>	<b>15137.2/1</b>	<b>15137.2/1</b>	<b>15137.2/1</b>	<b>15137.2/1</b>
<b>General</b>				
Mounting foot for DIN rails	TS 35	TS 35	TS 35	TS 35
Plug-in modules for	2.8mm fast-on	2.8 mm fast-on	2.8mm fast-on	2.8mm fast-on
Connection type	Screw connection	Screw connection	Screw connection	Screw connection
<b>Technical data</b>				
Rated current	10 A	10 A	10 A	10 A
Rated voltage	300 V	300 V	300 V	300 V
Dielectric strength	2400 Veff	2400 Veff	2400 Veff	2400 Veff
Insulation group (VDE 0110 b)	C/250 V	C/250 V	C/250 V	C/250 V
Ambient temperature	-25 to +80°C	-25 to +80°C	-25 to +80°C	-25 to +80°C
Protection degree, enclosure	IP 20	IP 20	IP 20	IP 20
Flammability class UL 94	V-0	V-0	V-0	V-0
Touch protection, acc. to	VBG 4	VBG 4	VBG 4	VBG 4
Connection cross-section	2 x 2.5 mm <sup>2</sup>	2 x 2.5 mm <sup>2</sup>	2 x 2.5 mm <sup>2</sup>	2 x 2.5 mm <sup>2</sup>
With ferrules	2 x 1.5 mm <sup>2</sup>	2 x 1.5 mm <sup>2</sup>	2 x 1.5 mm <sup>2</sup>	2 x 1.5 mm <sup>2</sup>
Screw torque	max. 0.8 Nm	max. 0.8 Nm	max. 0.8 Nm	max. 0.8 Nm
Approvals	UL/CSA	UL/CSA	UL/CSA	UL/CSA

Holding clamp	PRS C 4	PRS C 4	PRS C 4	PRS C 4
<b>Type</b>	<b>PRS C 4</b>	<b>PRS C 4</b>	<b>PRS C 4</b>	<b>PRS C 4</b>
<b>Cat. no./Qty.</b>	<b>15140.2/1</b>	<b>15140.2/1</b>	<b>15140.2/1</b>	<b>15140.2/1</b>

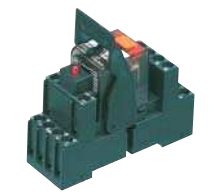
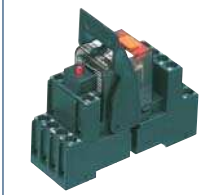
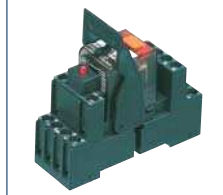
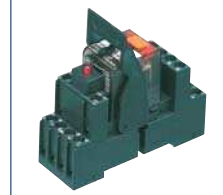
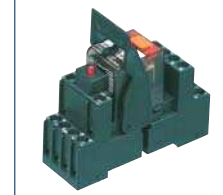
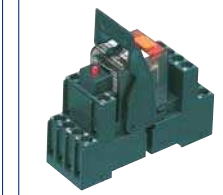
<b>PRSU 4/110 V DC</b>	<b>PRSU 4/220 V DC</b>	<b>PRSU 4/12 V AC</b>	<b>PRSU 4/24 V AC</b>	<b>PRSU 4/115 V AC</b>	<b>PRSU 4/230 V AC</b>
					
<b>PRSU 4/110 V DC 15726.2/1</b>	<b>PRSU 4/220 V DC 15727.2/1</b>	<b>PRSU 4/12 V AC 15392.2/1</b>	<b>PRSU 4/24 V AC 15168.2/1</b>	<b>PRSU 4/115 V AC 15728.2/1</b>	<b>PRSU 4/230 V AC 15174.2/1</b>
76 x 27.1 x 85 mm 95 g	76 x 27.1 x 85 mm 95 g	76 x 27.1 x 85 mm 95 g	76 x 27.1 x 85 mm 95 g	76 x 27.1 x 85 mm 95 g	76 x 27.1 x 85 mm 95 g

<b>PRS 4/110 V DC 15422.2/1</b>	<b>PRS 4/220 V DC 15368.2/1</b>	<b>PRS 4/12 V AC 15393.2/1</b>	<b>PRS 4/24 V AC 6488.2/1</b>	<b>PRS 4/115 V AC 15257.2/1</b>	<b>PRS 4/230 V AC 6489.2/1</b>
30 g	30 g	30 g	30 g	30 g	30 g

Insulation IEC 664/VDE 0110, rated voltage 250 V, pollution degree 3, overvoltage category III

2.5 kV -40 to +70°C	2.5 kV -40 to +70°C	2.5 kV -40 to +70°C	2.5 kV -40 to +70°C	2.5 kV -40 to +70°C	2.5 kV -40 to +70°C
110 V DC 0.75 W	220 V DC 0.75 W	12 V AC 1.0 VA	24 V AC 1.0 VA	115 V AC 1.0 VA	230 V AC 1.0 VA
4 CO contact 250 V/250 V AC 6 A/12 A 15 ms/10 ms AgNi 90/10 1.5 x 10 <sup>5</sup> 6 A, 250 V A > 30 x 10 <sup>6</sup>	4 CO contact 250 V/250 V AC 6 A/12 A 15 ms/10 ms AgNi 90/10 1.5 x 10 <sup>5</sup> 6 A, 250 V AC > 30 x 10 <sup>6</sup>	4 CO contact 250 V/250 V AC 6 A/12 A 15 ms/10 ms AgNi 90/10 1.5 x 10 <sup>5</sup> 6 A, 250 V AC > 20 x 10 <sup>6</sup>	4 CO contact 250 V/250 V AC 6 A/12 A 15 ms/10 ms AgNi 90/10 1.5 x 10 <sup>5</sup> 6 A, 250 V AC > 20 x 10 <sup>6</sup>	4 CO contact 250 V AC/250 V AC 6 A/12 A 15 ms/10 ms AgNi 90/10 1.5 x 10 <sup>5</sup> 6 A, 250 V AC > 20 x 10 <sup>6</sup>	4 CO contact 250 V AC/250 V AC 6 A/12 A 15 ms/10 ms AgNi 90/10 1.5 x 10 <sup>5</sup> 6 A, 250 V AC > 20 x 10 <sup>6</sup>

<b>PRS LED 110 V DC 15422.2/1</b>	<b>PRS LED 230 V AC 15142.2/1</b>	<b>PRS LED 24 V UC 15175.2/1</b>	<b>PRS LED 24 V UC 15175.2/1</b>	<b>PRS LED 230 V AC 15142.2/1</b>	<b>PRS LED 230 V AC 15142.2/1</b>
Status display with free-wheel diode 60 to 110 V DC	Status display 110 to 230 V DC	Status display 12 to 48 V AC/DC	Status display 12 to 48 V AC/DC	Status display 110 to 230 V AC/DC	Status display 110 to 230 V AC

<b>PRS 4 15137.2/1</b>	<b>PRS 4 15137.2/1</b>	<b>PRS 4 15137.2/1</b>	<b>PRS 4 15137.2/1</b>	<b>PRS 4 15137.2/1</b>	<b>PRS 4 15137.2/1</b>
TS 35 2.8mm fast-on Screw connection	TS 35 2.8mm fast-on Screw connection	TS 35 2.8mm fast-on Screw connection	TS 35 2.8mm fast-on Screw connection	TS 35 2.8mm fast-on Screw connection	TS 35 2.8mm fast-on Screw connection
10 A 300 V 2400 Veff C/250 V -25 to +80°C IP 20 V-0 VBG 4 2 x 2.5mm <sup>2</sup> 2 x 1.5mm <sup>2</sup> max. 0.8 Nm UL/CSA	10 A 300 V 2400 Veff C/250 V -25 to +80°C IP 20 V-0 VBG 4 2 x 2.5mm <sup>2</sup> 2 x 1.5mm <sup>2</sup> max. 0.8 Nm UL/CSA	10 A 300 V 2400 Veff C/250 V -25 to +80°C IP 20 V-0 VBG 4 2 x 2.5mm <sup>2</sup> 2 x 1.5mm <sup>2</sup> max. 0.8 Nm UL/CSA	10 A 300 V 2400 Veff C/250 V -25 to +80°C IP 20 V-0 VBG 4 2 x 2.5mm <sup>2</sup> 2 x 1.5mm <sup>2</sup> max. 0.8 Nm UL/CSA	10 A 300 V 2400 Veff C/250 V -25 to +80°C IP 20 V-0 VBG 4 2 x 2.5mm <sup>2</sup> 2 x 1.5mm <sup>2</sup> max. 0.8 Nm UL/CSA	10 A 300 V 2400 Veff C/250 V -25 to +80°C IP 20 V-0 VBG 4 2 x 2.5mm <sup>2</sup> 2 x 1.5mm <sup>2</sup> max. 0.8 Nm UL/CSA

<b>PRS C 4 15140.2/1</b>	<b>PRS C 4 15140.2/1</b>	<b>PRS C 4 15140.2/1</b>	<b>PRS C 4 15140.2/1</b>	<b>PRS C 4 15140.2/1</b>	<b>PRS C 4 15140.2/1</b>
------------------------------	------------------------------	------------------------------	------------------------------	------------------------------	------------------------------

## Relay 4 CO contact, PRS 4 G

### Complete screw-connection components

- consisting of:
- Relay
  - Insert module
  - Socket base
  - Holding clamp

#### PRS 4 G/12 V DC



#### PRS 4 G/24 V DC



#### PRS 4 G/48 V DC

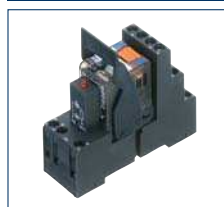

#### PRS 4 G/60 V DC



Type	PRS 4 G/12 V DC	PRS 4 G/24 V DC	PRS 4 G/48 V DC	PRS 4 G/60 V DC
Cat. no./Qty.	15421.2/1	15332.2/1	15729.2/1	15730.2/1
Size (L x W x H) with TS 35 x 7.5	76 x 27.1 x 87 mm	76 x 27.1 x 87 mm	76 x 27.1 x 87 mm	76 x 27.1 x 87 mm
Weight	95 g	95 g	95 g	95 g

### Individual components

#### Relay 4 W, open design, with switch

Type	PRS 4/12 V DC	PRS 4/24 V DC	PRS 4/48 V DC	PRS 4/60 V DC
Cat. no./Qty.	6486.2/1	6487.2/1	15461.2/1	15336.2/1
Weight	30 g	30 g	30 g	30 g
<b>General information</b>	Insulation IEC 664/VDE 0110, rated voltage 250 V, pollution degree 3, overvoltage category III			
DIN-VDE specifications	Insulation IEC 664/VDE 0110, rated voltage 250 V, pollution degree 3, overvoltage category III			
Test voltage coil/contact	2.5 kV	2.5 kV	2.5 kV	2.5 kV
Operating temperature	-40 to +70°C	-40 to +70°C	-40 to +70°C	-40 to +70°C
<b>Input data</b>				
Input voltage	12 V DC	24 V DC	48 V DC	60 V DC
Rated power consumption	0.75 W	0.75 W	0.75 W	0.75 W
<b>Output data</b>				
Contacts	4 CO contact	4 CO contact	4 CO contact	4 CO contact
Switching voltage/Max. switching voltage	250 V AC/250 V AC	250 V AC/250 V AC	250 V AC/250 V AC	250 V AC/250 V AC
Max continuous current/inrush current	6 A/12 A	6 A/12 A	6 A/12 A	6 A/12 A
Typical response time/release time	15 ms/10 ms	15 ms/10 ms	15 ms/10 ms	15 ms/10 ms
Contact material	AgNi 90/10	AgNi 90/10	AgNi 90/10	AgNi 90/10
Electrical service life at contact load	1.5 x 10 <sup>5</sup>	1.5 x 10 <sup>5</sup>	1.5 x 10 <sup>5</sup>	1.5 x 10 <sup>5</sup>
Mechanical life span	> 30 x 10 <sup>6</sup>	> 30 x 10 <sup>6</sup>	> 30 x 10 <sup>6</sup>	> 30 x 10 <sup>6</sup>

### Insert module





Type	PRS LED 24 V DC	PRS LED 24 V DC	PRS LED 24 V UC	PRS LED 110 V DC
Cat. no./Qty.	15141.2/1	15141.2/1	15175.2/1	15422.2/1
protected against polarity reversal in parallel to coil	Status display with free-wheel diode	Status display with free-wheel diode	Status display	Status display with free-wheel diode
	12 to 24 V DC	12 to 24 V DC	12 to 48 V AC/DC	60 to 110 V DC

### Socket base

Type	PRS 4 G	PRS 4 G	PRS 4 G	PRS 4 G
Cat. no./Qty.	15324.2/1	15324.2/1	15324.2/1	15324.2/1
<b>General</b>				
Mounting foot for DIN rails	TS 35	TS 35	TS 35	TS 35
Plug-in modules for	2.8mm fast-on	2.8mm fast-on	2.8mm fast-on	2.8mm fast-on
Connection type	Screw connection	Screw connection	Screw connection	Screw connection
<b>Technical data</b>				
Rated current	10 A	10 A	10 A	10 A
Rated voltage	300 V	300 V	300 V	300 V
Dielectric strength	2400 Veff	2400 Veff	2400 Veff	2400 Veff
Insulation group (VDE 0110 b)	C/250 V	C/250 V	C/250 V	C/250 V
Ambient temperature	-25 to +80°C	-25 to +80°C	-25 to +80°C	-25 to +80°C
Protection degree, enclosure	IP 20	IP 20	IP 20	IP 20
Flammability class UL 94	V-0	V-0	V-0	V-0
Touch protection, acc. to	VBG 4	VBG 4	VBG 4	VBG 4
Connection cross-section	2 x 2.5 mm <sup>2</sup>	2 x 2.5 mm <sup>2</sup>	2 x 2.5 mm <sup>2</sup>	2 x 2.5 mm <sup>2</sup>
With ferrules	2 x 1.5 mm <sup>2</sup>	2 x 1.5 mm <sup>2</sup>	2 x 1.5 mm <sup>2</sup>	2 x 1.5 mm <sup>2</sup>
Screw torque	max. 0.8 Nm	max. 0.8 Nm	max. 0.8 Nm	max. 0.8 Nm
Approvals	UL/CSA	UL/CSA	UL/CSA	UL/CSA

### Holding clamp

Type	PRS C 4	PRS C 4	PRS C 4	PRS C 4
Cat. no./Qty.	15140.2/1	15140.2/1	15140.2/1	15140.2/1

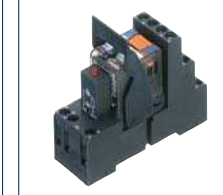
<b>PRSU 4 G/110 V DC</b>	<b>PRSU 4 G/220 V DC</b>	<b>PRSU 4 G/12 V AC</b>	<b>PRSU 4 G/24 V AC</b>	<b>PRSU 4 G/115 V AC</b>	<b>PRSU 4 G/230 V AC</b>
					
<b>PRSU 4 G/110 V DC 15731.2/1</b>	<b>PRSU 4 G/220 V DC 15732.2/1</b>	<b>PRSU 4 G/12 V AC 15420.2/1</b>	<b>PRSU 4 G/24 V AC 15371.2/1</b>	<b>PRSU 4 G/115 V AC 15733.2/1</b>	<b>PRSU 4 G/230 V AC 15372.2/1</b>
76 x 27.1 x 87 mm 95 g	76 x 27.1 x 87 mm 95 g	76 x 27.1 x 87 mm 95 g	76 x 27.1 x 87 mm 95 g	76 x 27.1 x 87 mm 95 g	76 x 27.1 x 87 mm 95 g

<b>PRS 4/110 V DC 15442.2/1</b>	<b>PRS 4/220 V DC 15368.2/1</b>	<b>PRS 4/12 V AC 15393.2/1</b>	<b>PRS 4/24 V AC 6488.2/1</b>	<b>PRS 4/115 V AC 15257.2/1</b>	<b>PRS 4/230 V AC 6489.2/1</b>
30 g	30 g	30 g	30 g	30 g	30 g

Insulation IEC 664/VDE 0110, rated voltage 250 V, pollution degree 3, overvoltage category III					
2.5 kV -40 to +70°C	2.5 kV -40 to +70°C	2.5 kV -40 to +70°C	2.5 kV -40 to +70°C	2.5 kV -40 to +70°C	2.5 kV -40 to +70°C
110 V DC 0.75 W	220 V DC 0.75 W	12 V AC 1.0 VA	24 V AC 1.0 VA	115 V AC 1.0 VA	230 V AC 1.0 VA
4 CO contact 250 V AC/250 V AC 6 A/12 A 15 ms/10 ms AgNi 90/10 1.5 x 10 <sup>5</sup> 6 A, 250 V AC > 30 x 10 <sup>6</sup>	4 CO contact 250 V AC/250 V AC 6 A/12 A 15 ms/10 ms AgNi 90/10 1.5 x 10 <sup>5</sup> 6 A, 250 V AC > 30 x 10 <sup>6</sup>	4 CO contact 250 V AC/250 V AC 6 A/12 A 15 ms/10 ms AgNi 90/10 1.5 x 10 <sup>5</sup> 6 A, 250 V AC > 20 x 10 <sup>6</sup>	4 CO contact 250 V AC/250 V AC 6 A/12 A 15 ms/10 ms AgNi 90/10 1.5 x 10 <sup>5</sup> 6 A, 250 V AC > 20 x 10 <sup>6</sup>	4 CO contact 250 V AC/250 V AC 6 A/12 A 15 ms/10 ms AgNi 90/10 1.5 x 10 <sup>5</sup> 6 A, 250 V AC > 20 x 10 <sup>6</sup>	4 CO contact 250 V AC/250 V AC 6 A/12 A 15 ms/10 ms AgNi 90/10 1.5 x 10 <sup>5</sup> 6 A, 250 V AC > 20 x 10 <sup>6</sup>

<b>PRS LED 110 V DC 15422.2/1</b>	<b>PRS LED 230 V AC 15142.2/1</b>	<b>PRS LED 24 V UC 15175.2/1</b>	<b>PRS LED 24 V UC 15175.2/1</b>	<b>PRS LED 230 V AC 15142.2/1</b>	<b>PRS LED 230 V AC 15142.2/1</b>
Status display with free-wheel diode 60 to 110 V DC	Status display 110 to 230 V AC	Status display 12 to 48 V AC/DC	Status display 12 to 48 V AC/DC	Status display 110 to 230 V AC	Status display 110 to 230 V AC

<b>PRS 4 G 15324.2/1</b>	<b>PRS 4 G 15324.2/1</b>	<b>PRS 4 G 15324.2/1</b>	<b>PRS 4 G 15324.2/1</b>	<b>PRS 4 G 15324.2/1</b>	<b>PRS 4 G 15324.2/1</b>
TS 35 2.8mm fast-on Screw connection	TS 35 2.8mm fast-on Screw connection	TS 35 2.8mm fast-on Screw connection	TS 35 2.8mm fast-on Screw connection	TS 35 2.8mm fast-on Screw connection	TS 35 2.8mm fast-on Screw connection
10 A 300 V 2400 Veff C/250 V -25 to +80°C IP 20 V-0 VBG 4 2 x 2.5 mm <sup>2</sup> 2 x 1.5 mm <sup>2</sup> max. 0.8 Nm UL/CSA	10 A 300 V 2400 Veff C/250 V -25 to +80°C IP 20 V-0 VBG 4 2 x 2.5 mm <sup>2</sup> 2 x 1.5 mm <sup>2</sup> max. 0.8 Nm UL/CSA	10 A 300 V 2400 Veff C/250 V -25 to +80°C IP 20 V-0 VBG 4 2 x 2.5 mm <sup>2</sup> 2 x 1.5 mm <sup>2</sup> max. 0.8 Nm UL/CSA	10 A 300 V 2400 Veff C/250 V -25 to +80°C IP 20 V-0 VBG 4 2 x 2.5 mm <sup>2</sup> 2 x 1.5 mm <sup>2</sup> max. 0.8 Nm UL/CSA	10 A 300 V 2400 Veff C/250 V -25 to +80°C IP 20 V-0 VBG 4 2 x 2.5 mm <sup>2</sup> 2 x 1.5 mm <sup>2</sup> max. 0.8 Nm UL/CSA	10 A 300 V 2400 Veff C/250 V -25 to +80°C IP 20 V-0 VBG 4 2 x 2.5 mm <sup>2</sup> 2 x 1.5 mm <sup>2</sup> max. 0.8 Nm UL/CSA

<b>PRS C 4 15140.2/1</b>	<b>PRS C 4 15140.2/1</b>	<b>PRS C 4 15140.2/1</b>	<b>PRS C 4 15140.2/1</b>	<b>PRS C 4 15140.2/1</b>	<b>PRS C 4 15140.2/1</b>
------------------------------	------------------------------	------------------------------	------------------------------	------------------------------	------------------------------

## Relay 4 CO PRS 4 eco

### Complete screw or tension-spring connection unit

consisting of:

- Relay
- Socket base

	PRSU 4/24V DC eco	PRSU 4/24V AC eco	PRSU 4/230V AC eco	PRSU 4G/24V DC eco
				
<b>Type</b>	<b>PRSU 4/24V DC eco</b>	<b>PRSU 4/24V AC eco</b>	<b>PRSU 4/230V AC eco</b>	<b>PRSU 4G/24V DC eco</b>
<b>Cat. no./Qty.</b>	<b>15619.2 / 1</b>	<b>15620.2 / 1</b>	<b>15621.2 / 1</b>	<b>15622.2 / 1</b>
Size (L x W x H) with TS 35 x 7.5	76 x 27.1 x 68 mm	76 x 27.1 x 68 mm	76 x 27.1 x 68 mm	78 x 27.1 x 70 mm
Weight	98g	98g	98g	100g

### Individual components

#### Relay 4W, open design, with switch and status display

	PRS 4/24V DC eco	PRS 4/24V AC eco	PRS 4/230V AC eco	PRS 4/24V DC eco
<b>Type</b>	<b>PRS 4/24V DC eco</b>	<b>PRS 4/24V AC eco</b>	<b>PRS 4/230V AC eco</b>	<b>PRS 4/24V DC eco</b>
<b>Cat. no./Qty.</b>	<b>15591.2 / 1</b>	<b>15592.2 / 1</b>	<b>15593.2 / 1</b>	<b>15591.2 / 1</b>
Weight	35g	35g	35g	35g

### Common data

DIN-VDE specifications	Insulation IEC 664/VDE 0110, Rated voltage 250V, contamination degree 2, overvoltage category III,			
Test voltage coil/contact	2.5 KV	2.5 KV	2.5 KV	2.5 KV
Operating temperature	-25 °C to +70°C	-25 to +55°C	-25 to +55°C	-25 °C to +70°C
Lockable test button	yes	yes	yes	yes
Indicators	red LED	red LED	red LED	red LED
Mechanical indicator	yes	yes	yes	yes
Free-wheel diode	yes	no	no	yes
<b>Input data</b>				
Input voltage	24 V DC	24V AC	230V AC	24 V DC
Rated power consumption	0.9 W	1.6 VA	1.6 VA	0.9 W
Frequency	-	50/60 Hz	50/60 Hz	-
<b>Output specifications</b>				
Contacts	4 CO contact	4 CO contact	4 CO contact	4 CO contact
Max. switching voltage AC / DC	250 V /250 V	250 V /250 V	250 V /250 V	250 V /250 V
Min. switching voltage	5 V	5 V	5 V	5 V
Max. continuous current	6 A, 250 V AC	6 A, 250 V AC	6 A, 250 V AC	6 A, 250 V AC
	DC 1	6 A / 24 V DC	6 A / 24 V DC	6 A / 24 V DC
Max inrush current	12 A	12 A	12 A	12 A
Contact load	AC 1	1500VA	1500VA	1500VA
Min. contact load	0.3W	0.3W	0.3W	0.3W
Contact resistance	≤ 100 mΩ	≤ 100 mΩ	≤ 100 mΩ	≤ 100 mΩ
Max. switching frequency at operating load	1200 Cycles per hour	1200 Cycles per hour	1200 Cycles per hour	1200 Cycles per hour
Max. switching frequency without load	18000 Cycles per hour	18000 Cycles per hour	18000 Cycles per hour	18000 Cycles per hour
Typical response time/release time	13 ms / 3 ms	13 ms / 3 ms	13 ms / 3 ms	13 ms / 3 ms
Contact material	AgNi	AgNi	AgNi	AgNi
Electrical service life	AC 1	≥ 1 x 10 <sup>5</sup>	≥ 1 x 10 <sup>5</sup>	≥ 1 x 10 <sup>5</sup>
Mechanical service life	≥ 2 x 10 <sup>7</sup>	≥ 2 x 10 <sup>7</sup>	≥ 2 x 10 <sup>7</sup>	≥ 2 x 10 <sup>7</sup>

### Socket base

	PRS 4	PRS 4	PRS 4	PRS 4 G
<b>Type</b>	<b>PRS 4</b>	<b>PRS 4</b>	<b>PRS 4</b>	<b>PRS 4 G</b>
<b>Cat. no./Qty.</b>	<b>15137.2 / 1</b>	<b>15137.2 / 1</b>	<b>15137.2 / 1</b>	<b>15324.2 / 1</b>
Overview				
Mounting foot for DIN rails	TS 35	TS 35	TS 35	TS 35
Plug-in base for	2.8mm fast-on	2.8mm fast-on	2.8mm fast-on	2.8mm fast-on
Connection type	Screw connection	Screw connection	Screw connection	Screw connection
<b>Technical data</b>				
Rated current	10 A	10 A	10 A	10 A
Rated voltage	300 V	300 V	300 V	300 V
Dielectric strength	2400 Veff	2400 Veff	2400 Veff	2400 Veff
Insulation group (VDE 0110b)	C/250 V	C/250 V	C/250 V	C/250 V
Ambient temperature	-25 °C to +80°C	-25 °C to +80°C	-25 °C to +80°C	-25 °C to +80°C
Protection degree, enclosure	IP 20	IP 20	IP 20	IP 20
Flammability class UL 94	V-0	V-0	V-0	V-0
Touch protection, acc. to	VBG 4	VBG 4	VBG 4	VBG 4
Connection cross-section	2 x 2.5 mm <sup>2</sup>	2 x 2.5 mm <sup>2</sup>	2 x 2.5 mm <sup>2</sup>	2 x 2.5 mm <sup>2</sup>
With ferrules	2 x 1.5 mm <sup>2</sup>	2 x 1.5 mm <sup>2</sup>	2 x 1.5 mm <sup>2</sup>	2 x 1.5 mm <sup>2</sup>
Screw torque	max. 0.8 Nm	max. 0.8 Nm	max. 0.8 Nm	max. 0.8 Nm
Stripping length	7 mm	7 mm	7 mm	7 mm
Approvals	UL/CSA	UL/CSA	UL/CSA	UL/CSA

### Accessory: Holding clamp (optional)

	PRS C4 eco	PRS C4 eco	PRS C4 eco	PRS C4 eco
<b>Type</b>	<b>PRS C4 eco</b>	<b>PRS C4 eco</b>	<b>PRS C4 eco</b>	<b>PRS C4 eco</b>
<b>Cat. no./Qty.</b>	<b>15628.2 / 1</b>	<b>15628.2 / 1</b>	<b>15628.2 / 1</b>	<b>15628.2 / 1</b>

<b>PRSU 4G/24V AC eco</b>	<b>PRSU 4G/230V AC eco</b>	<b>PRSU 4Z/24V DC eco</b>	<b>PRSU 4Z/24V AC eco</b>	<b>PRSU 4Z/230V AC eco</b>	
					
<b>PRSU 4G/24V AC eco</b> <b>15623.2 / 1</b> 78 x 27.1 x 70 mm 100g	<b>PRSU 4G/230V AC eco</b> <b>15624.2 / 1</b> 78 x 27.1 x 70 mm 100g	<b>PRSU 4Z/24V DC eco</b> <b>15625.2 / 1</b> 98 x 31 x 69.2 mm 109g	<b>PRSU 4Z/24V AC eco</b> <b>15626.2 / 1</b> 98 x 31 x 69.2 mm 109g	<b>PRSU 4Z/230V AC eco</b> <b>15627.2 / 1</b> 98 x 31 x 69.2 mm 109g	

<b>PRS 4/24V AC eco</b> <b>15592.2 / 1</b> 35g	<b>PRS 4/230V AC eco</b> <b>15593.2 / 1</b> 35g	<b>PRS 4/24V DC eco</b> <b>15591.2 / 1</b> 35g	<b>PRS 4/24V AC eco</b> <b>15592.2 / 1</b> 35g	<b>PRS 4/230V AC eco</b> <b>15593.2 / 1</b> 35g	
--	---	--	--	---	--

Insulation IEC 664/VDE 0110, Rated voltage 250V, contamination degree 2, overvoltage category III,					
2.5 KV	2.5 KV	2.5 KV	2.5 KV	2.5 KV	
-25 to +55°C	-25 to +55°C	-25 °C to +70°C	-25 to +55°C	-25 to +55°C	
yes	yes	yes	yes	yes	
red LED	red LED	red LED	red LED	red LED	
yes	yes	yes	yes	yes	
no	no	yes	no	no	
24V AC	230V AC	12V DC	24V AC	230V AC	
1.6 VA	1.6 VA	0.9 W	1.6 VA	1.6 VA	
50/60 Hz	50/60 Hz	-	50/60 Hz	50/60 Hz	
4 CO contact	4 CO contact	4 CO contact	4 CO contact	4 CO contact	
250 V /250 V	250 V /250 V	250 V /250 V	250 V /250 V	250 V /250 V	
5 V	5 V	5 V	5 V	5 V	
6 A, 250 V AC	6 A, 250 V AC	6 A, 250 V AC	6 A, 250 V AC	6 A, 250 V AC	
6 A / 24 V DC	6 A / 24 V DC	6 A / 24 V DC	6 A / 24 V DC	6 A / 24 V DC	
12 A	12 A	12 A	12 A	12 A	
1500VA	1500VA	1500VA	1500VA	1500VA	
0.3W	0.3W	0.3W	0.3W	0.3W	
≤ 100 mΩ	≤ 100 mΩ	≤ 100 mΩ	≤ 100 mΩ	≤ 100 mΩ	
1200 Cycles per hour	1200 Cycles per hour	1200 Cycles per hour	1200 Cycles per hour	1200 Cycles per hour	
18000 Cycles per hour	18000 Cycles per hour	18000 Cycles per hour	18000 Cycles per hour	18000 Cycles per hour	
13 ms / 3 ms	13 ms / 3 ms	13 ms / 3 ms	13 ms / 3 ms	13 ms / 3 ms	
AgNi	AgNi	AgNi	AgNi	AgNi	
≥ 1 x 10 <sup>5</sup>	≥ 1 x 10 <sup>5</sup>	≥ 1 x 10 <sup>5</sup>	≥ 1 x 10 <sup>5</sup>	≥ 1 x 10 <sup>5</sup>	
≥ 2 x 10 <sup>7</sup>	≥ 2 x 10 <sup>7</sup>	≥ 2 x 10 <sup>7</sup>	≥ 2 x 10 <sup>7</sup>	≥ 2 x 10 <sup>7</sup>	

<b>PRS 4 G</b> <b>15324.2 / 1</b>	<b>PRS 4 G</b> <b>15324.2 / 1</b>	<b>PRS 4 Z</b> <b>15431.2 / 1</b>	<b>PRS 4 Z</b> <b>15431.2 / 1</b>	<b>PRS 4 Z</b> <b>15431.2 / 1</b>	
TS 35	TS 35	TS 35	TS 35	TS 35	
2.8mm fast-on	2.8mm fast-on	2.8mm fast-on	2.8mm fast-on	2.8mm fast-on	
Screw connection	Screw connection	Tension-spring connection	Tension-spring connection	Tension-spring connection	
10 A	10 A	12 A	12 A	12 A	
300 V	300 V	300 V	300 V	300 V	
2400 Veff	2400 Veff	> 2500 Veff	> 2500 Veff	> 2500 Veff	
C/250 V	C/250 V	C/250 V	C/250 V	C/250 V	
-25 °C to +80°C	-25 °C to +80°C	-25 °C to +70°C	-25 °C to +70°C	-25 °C to +70°C	
IP 20	IP 20	IP 20	IP 20	IP 20	
V-0	V-0	V-0	V-0	V-0	
VBG 4	VBG 4	VBG 4	VBG 4	VBG 4	
2 x 2.5 mm <sup>2</sup>	2 x 2.5 mm <sup>2</sup>	2 x 0.2 - 1.5 mm <sup>2</sup>	2 x 0.2 - 1.5 mm <sup>2</sup>	2 x 0.2 - 1.5 mm <sup>2</sup>	
2 x 1.5 mm <sup>2</sup>	2 x 1.5 mm <sup>2</sup>	2 x 0.2 - 0.75 mm <sup>2</sup>	2 x 0.2 - 0.75 mm <sup>2</sup>	2 x 0.2 - 0.75 mm <sup>2</sup>	
max. 0.8 Nm	max. 0.8 Nm	-	-	-	
7 mm	7 mm	7 mm	7 mm	7 mm	
UL/CSA	UL/CSA	UL/CSA	UL/CSA	UL/CSA	

<b>PRS C4 eco</b> <b>15628.2 / 1</b>	<b>PRS C4 eco</b> <b>15628.2 / 1</b>	<b>PRS C4 eco</b> <b>15628.2 / 1</b>	<b>PRS C4 eco</b> <b>15628.2 / 1</b>	<b>PRS C4 eco</b> <b>15628.2 / 1</b>	
---	---	---	---	---	--

## Plug relay system PRS

### Tension-spring connection

The **PRS Z** relay bases extend the **PRS** plug-relay system with their wide-spread tension-spring connection mechanism. Each of the base's conductor connections is doubled in order to allow for a simple double potential pick-off (test point). The well-known advantages of the **PRS** relay system also apply to this base. The entire line of accessories with which you are already familiar are compatible and can be used with the bases. So you can make use of the same illuminated displays and holding clamps that are used with the screw connection mechanism. Dependable functioning is always certain because of the combination with the proven **PRS**-system relays.

### 1. Overview

**a Pluggable relays**  
Pluggable relays are also available with AgSNO and gold contacts, to fit with the many functions of your individual requirements!



**e Mounts on standard TS 35 rail**  
**CONTA-CLIP** relay bases can be flexibly mounted on standard TS 35 mounting rails according to EN 50035 and EN 50022.

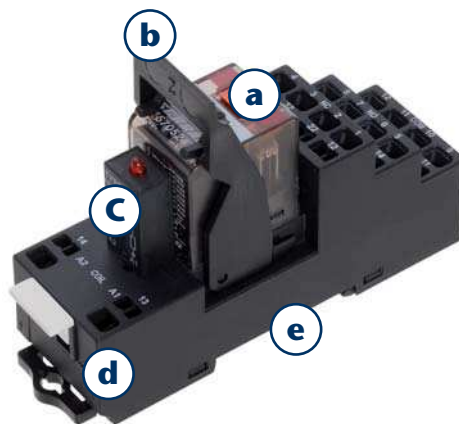

**b Using the mount/dismount lever**  
The mounting and dismounting mechanism forms a reliable connection by latching the relay with the socket base. The fitted relay can be removed, easily and without force, from the socket base by using the dismount function of the lever!

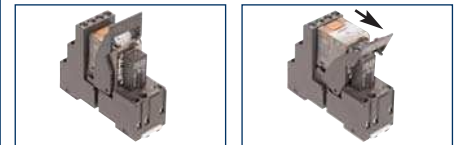

#### AQI/PRS external cross-connector

**d** The AQI/PRS external cross-connection system enables a time-saving distribution of potentials. With this system, you can save time when coupling multiple relay components.

**c Pluggable LED and protective modules**  
Pluggable modules allow easy insertion into the base, with reverse-connect protection. The module circuitry is effective in parallel to the coil of the deployed relay.



### 2. Features

#### 1. Relay

- **PLUG RELAY SYSTEM** (relays with 1, 2, or 4 COs)
- Load-independent switching
- Direct control via the PLC outputs
- High interference immunity
- Electrical isolation of control and load circuits
- Minimal contact resistance, and high insulation resistance
- PRS XT relay features switch/button for HAND/AUTOMATIC switching and an integrated LED to show the status of the switch
- PRS 4 relay features switch/button for HAND/AUTOMATIC switching
- PRS 4 eco relay features switch/button for HAND/AUTOMATIC switching, and an integrated LED for signalling the switching status

Technical data for the available relays can be found on the following product pages.



# Plug relay system PRS

## Tension-spring connection

### II. Socket base

- Mount on TS 35
- Very flexible and modular construction of individual relay bases
- User-friendly, because the relays can be easily replaced
- High-quality connection terminals
- Doubled connections
- Pluggable LED display with additional protective circuitry
- Holding clamp made of high-quality plastic

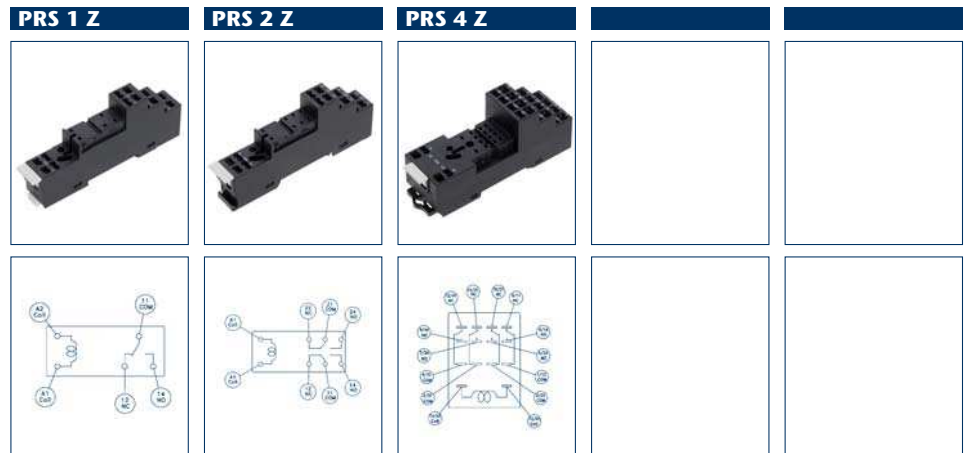

Type	PRS 1 Z	PRS 2 Z	PRS 4 Z		
<b>Cat. no./Qty.</b>	<b>15780.2/1</b>	<b>15789.2/1</b>	<b>15431.2/1</b>		
Size (L x W x H) with TS 35	98 x 16.3 x 47.5 mm	98 x 16.3 x 47.5 mm	98 x 31 x 47.5 mm		
Size with holding clamp (L x W x H) with TS 35	98 x 16.3 x 69.2 mm	98 x 16.3 x 69.2 mm	98 x 31 x 69.2 mm		
Weight	42 g	44 g	74 g		
<b>General</b>					
Mounting foot for DIN rails	TS 35	TS 35	TS 35		
Plug-in modules for	3.5 mm pinning	5 mm pinning	2.8 mm fast-on		
Connection type	Tension-spring	Tension-spring	Tension-spring		
<b>Technical data</b>					
Rated current	12 A	10 A	12 A		
Rated voltage	300 V	300 V	300 V		
Dielectric strength coil/contact	> 2500 Veff	> 2500 Veff	> 2500 Veff		
Insulation group (VDE 0110 b)	C/250 V	C/250 V	C/250 V		
Ambient temperature	-25 to +70°C	-25 to +70°C	-25 to +70°C		
Protection degree, enclosure	IP 20	IP 20	IP 20		
Flammability class UL 94	V-0	V-0	V-0		
Touch protection, acc. to	VBG 4	VBG 4	VBG 4		
Connection cross-section	2 x 0.2 - 1.5 mm <sup>2</sup>	2 x 0.2 - 1.5 mm <sup>2</sup>	2 x 0.2 - 1.5 mm <sup>2</sup>		
With ferrule	2 x 0.2 - 0.75 mm <sup>2</sup>	2 x 0.2 - 0.75 mm <sup>2</sup>	2 x 0.2 - 0.75 mm <sup>2</sup>		
Insulation stripping length	7 mm	7 mm	7 mm		
Approvals	UL/CSA	UL/CSA	UL/CSA		

### III. Insert modules

- Plugs simply into the base, reverse-connect protection
- Circuitry parallel to coil

Cat. no./Qty.	Type	Voltage range	
<b>15141.2/1</b>	PRS LED(RD) 24V DC	12 to 24 V DC	Status display with free-wheel diode
<b>15142.2/1</b>	PRS LED(RD) 230V AC	110 to 230 V AC	Status display
<b>15175.2/1</b>	PRS LED(RD) 24V UC	12 to 48 V AC/DC	Status display
<b>15422.2/1</b>	PRS LED(RD)/110V DC	60 to 110 V DC	Status display with free-wheel diode
<b>15810.2/1</b>	PRS LED(RD) 230V UC Var.	24 V AC/DC	Status display with varistor
<b>16070.2/1</b>	PRS LED(GN) 24V UC Var.	230 V AC/DC	Status display with varistor
<b>15808.2/1</b>	PRS RC 24V AC	24 V AC	Plug-in module with RC element
<b>15809.2/1</b>	PRS RC 240V AC	240 V AC	Plug-in module with RC element

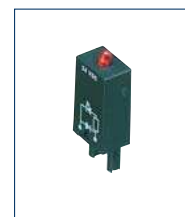



### IV. Holding clamp

The mount/dismount clamp forms a reliable connection by latching the relay with the socket base. The fitted relay can be removed, easily and without force, from the socket base by using the dismount function of the lever.

Cat. no./Qty.	Type	Weight
<b>15138.2/1</b>	PRS C 1/C 2	2 g
<b>15140.2/1</b>	PRS C 4	4 g
<b>15628.2/1</b>	PRS C 4 eco	4 g
<b>16016.2/1</b>	PRSXT C1/2	4 g



## Relay 1-CO PRS 1 XT

<b>Complete tension-spring connection units</b> consisting of: · Relay · Socket base · Holding clamp	<b>PRSUXT 1Z/24V DC</b> 	<b>PRSUXT 1Z/24V AC</b> 	<b>PRSUXT 1Z/230V AC</b> 	
<b>Type</b> <b>Cat. no./Qty.</b> Size (L x W x H) with TS 35 x 7.5 Weight	<b>PRSUXT 1Z/24V DC</b> <b>16092.2 / 1</b> 98 x 16.3 x 69.2 mm 60g	<b>PRSUXT 1Z/24V AC</b> <b>16093.2 / 1</b> 98 x 16.3 x 69.2 mm 60g	<b>PRSUXT 1Z/230V AC</b> <b>16094.2 / 1</b> 98 x 16.3 x 69.2 mm 60g	

### Individual components Relay 1W, open design, with switch and status display

<b>Type</b> <b>Cat. no./Qty.</b> Dimensions (L x W x H) Weight	<b>PRSXT 1/24V DC</b> <b>16083.2 / 1</b> 29 x 13 x 30.55 mm 16g	<b>PRSXT 1/24V AC</b> <b>16084.2 / 1</b> 29 x 13 x 30.55 mm 16g	<b>PRSXT 1/230V AC</b> <b>16085.2 / 1</b> 29 x 13 x 30.55 mm 16g	
<b>Common data</b> DIN-VDE specifications Test voltage coil/contact Operating temperature Lockable test button Indicators Mechanical indicator Free-wheel diode	Insulation IEC 664/VDE 0110, Rated voltage 250 V, contamination degree 3, Overvoltage category III, Flammability class UL 94 V-0			
<b>Input data</b> Input voltage Rated power consumption Frequency	24 V DC 0.4W -	24V AC 0.76VA 50/60 Hz	230V AC 0.74VA 50/60 Hz	
<b>Output specifications</b> Contacts Switching voltage/Max. switching voltage Max. continuous current Max. inrush current 4s / 30 ms Max. contact load Min. suggested contact load Voltage drop Max. switching frequency at operating load Max. switching frequency without load Typical response time/release time Contact material Electrical service life Mechanical service life	1 CO contact 240 V AC/400 V AC 16 A / 240 V AC 30 A /300 A 4000 VA 12V at 10mA 30mV at 100mA/6VDC 360 Cycles per hour 36000 Cycles per hour 8 ms/6 ms AgNi 90/10 50 x 10 <sup>3</sup> 10 x 10 <sup>6</sup>	1 CO contact 240 V AC/400 V AC 16 A, 240 V AC 30 A /300 A 4000 VA 12V at 10mA 30mV at 100mA/6VDC 360 Cycles per hour 36000 Cycles per hour 8 ms/6 ms AgNi 90/10 50 x 10 <sup>3</sup> 5 x 10 <sup>6</sup>	1 CO contact 240 V AC/400 V AC 16 A, 240 V AC 30 A /300 A 4000 VA 12V at 10mA 30mV at 100mA/6VDC 360 Cycles per hour 36000 Cycles per hour 8 ms/6 ms AgNi 90/10 50 x 10 <sup>3</sup> 5 x 10 <sup>6</sup>	



### Socket base

<b>Type</b> <b>Cat. no./Qty.</b> <b>Overview</b> Mounting foot for DIN rails Plug-in base for Connection type	<b>PRS 2 Z</b> <b>15789.2 / 1</b> TS 35 5mm pinning Tension-spring connection	<b>PRS 2 Z</b> <b>15789.2 / 1</b> TS 35 5mm pinning Tension-spring connection	<b>PRS 2 Z</b> <b>15789.2 / 1</b> TS 35 5mm pinning Tension-spring connection	
<b>Technical data</b> Rated current Rated voltage Dielectric strength Insulation group (VDE 0110b) Ambient temperature Protection degree, enclosure Flammability class UL 94 Touch protection, acc. to Connection cross-section With ferrules Stripping length Approvals	10A 300 V > 2500 Veff C/250 V -25 °C to +70°C IP 20 V-0 VBG 4 2 x 0.2 - 1.5 mm <sup>2</sup> 2 x 0.2 - 0.75 mm <sup>2</sup> 7 mm UL/CSA	10A 300 V > 2500 Veff C/250 V -25 °C to +70°C IP 20 V-0 VBG 4 2 x 0.2 - 1.5 mm <sup>2</sup> 2 x 0.2 - 0.75 mm <sup>2</sup> 7 mm UL/CSA	10A 300 V > 2500 Veff C/250 V -25 °C to +70°C IP 20 V-0 VBG 4 2 x 0.2 - 1.5 mm <sup>2</sup> 2 x 0.2 - 0.75 mm <sup>2</sup> 7 mm UL/CSA	

### Holding clamp

<b>Type</b> <b>Cat. no./Qty.</b>	<b>PRSXT C1/2</b> <b>16016.2 / 20</b>	<b>PRSXT C1/2</b> <b>16016.2 / 20</b>	<b>PRSXT C1/2</b> <b>16016.2 / 20</b>	
-------------------------------------	--	--	--	--

## Relay 2-CO PRS 2 XT

Complete tension-spring connection units consisting of:	PRSUXT 2Z/24V DC	PRSUXT 2Z/24V AC	PRSUXT 2Z/230V AC	
<ul style="list-style-type: none"> <li>Relay</li> <li>Socket base</li> <li>Holding clamp</li> </ul>				

Type	PRSUXT 2Z/24V DC	PRSUXT 2Z/24V AC	PRSUXT 2Z/230V AC	
<b>Cat. no./Qty.</b>	<b>16023.2 / 1</b>	<b>16024.2 / 1</b>	<b>16025.2 / 1</b>	
Size (L x W x H) with TS 35 x 7.5	98 x 16.3 x 69.2 mm	98 x 16.3 x 69.2 mm	98 x 16.3 x 69.2 mm	
Weight	60g	60g	60g	

### Individual components

#### Relay 2W, open design, with switch and status display

Type	PRSXT 2/24V DC	PRSXT 2/24V AC	PRSXT 2/230V AC	
<b>Cat. no./Qty.</b>	<b>16013.2 / 1</b>	<b>16014.2 / 1</b>	<b>16015.2 / 1</b>	
Dimensions (L x W x H)	29 x 13 x 30.55 mm	29 x 13 x 30.55 mm	29 x 13 x 30.55 mm	
Weight	16g	16g	16g	

Common data	Insulation IEC 664/VDE 0110, Rated voltage 250 V, contamination degree 3, Overvoltage category III, Flammability class UL 94 V-0			
DIN-VDE specifications	Insulation IEC 664/VDE 0110, Rated voltage 250 V, contamination degree 3, Overvoltage category III, Flammability class UL 94 V-0			
Test voltage coil/contact	2.5 kV	2.5 kV	2.5 kV	
Operating temperature	-40 to +70°C	-40 to +70°C	-40 to +70°C	
Lockable test button	yes	yes	yes	
Indicators	red LED	red LED	red LED	
Mechanical indicator	yes	yes	yes	
Free-wheel diode	yes	no	no	
Input data				
Input voltage	24 V DC	24V AC	230V AC	
Rated power consumption	0.4W	0.76VA	0.74VA	
Frequency	-	50/60 Hz	50/60 Hz	
Output specifications				
Contacts	2 CO contact	2 CO contact	2 CO contact	
Switching voltage/Max. switching voltage	240 V AC/400 V AC	240 V AC/400 V AC	240 V AC/400 V AC	
Max. continuous current	8 A, 240 V AC	8 A, 240 V AC	8 A, 240 V AC	
Max. inrush current 4s / 30 ms	15 A /300 A	15 A /300 A	15 A /300 A	
Max. contact load	2000 VA	2000 VA	2000 VA	
Min. suggested contact load	12V at 10mA	12V at 10mA	12V at 10mA	
Voltage drop	30mV at 100mA/6VDC	30mV at 100mA/6VDC	30mV at 100mA/6VDC	
Max. switching frequency at operating load	360 Cycles per hour	360 Cycles per hour	360 Cycles per hour	
Max. switching frequency without load	36000 Cycles per hour	36000 Cycles per hour	36000 Cycles per hour	
Typical response time/release time	10 ms/5 ms	10 ms/5 ms	10 ms/5 ms	
Contact material	AgNi 90/10	AgNi 90/10	AgNi 90/10	
Electrical service life	50 x 10 <sup>3</sup>	50 x 10 <sup>3</sup>	50 x 10 <sup>3</sup>	
Mechanical service life	10 x 10 <sup>6</sup>	5 x 10 <sup>6</sup>	5 x 10 <sup>6</sup>	

### Socket base

Type	PRS 2 Z	PRS 2 Z	PRS 2 G	
<b>Cat. no./Qty.</b>	<b>15789.2 / 1</b>	<b>15789.2 / 1</b>	<b>15320.2 / 1</b>	
Overview				
Mounting foot for DIN rails	TS 35	TS 35	TS 35	
Plug-in base for	5mm pinning	5mm pinning	5mm pinning	
Tension-spring connection	Tension-spring connection	Tension-spring connection	Tension-spring connection	
Technical data				
Rated current	10A	10A	10A	
Rated voltage	300 V	300 V	300 V	
Dielectric strength	> 2500 Veff	> 2500 Veff	> 2500 Veff	
Insulation group (VDE 0110b)	C/250 V	C/250 V	C/250 V	
Ambient temperature	-25 °C to +70°C	-25 °C to +70°C	-25 °C to +70°C	
Protection degree, enclosure	IP 20	IP 20	IP 20	
Flammability class UL 94	V-0	V-0	V-0	
Touch protection, acc. to	VBG 4	VBG 4	VBG 4	
Connection cross-section	2 x 0.2 - 1.5 mm <sup>2</sup>	2 x 0.2 - 1.5 mm <sup>2</sup>	2 x 0.2 - 1.5 mm <sup>2</sup>	
With ferrules	2 x 0.2 - 0.75 mm <sup>2</sup>	2 x 0.2 - 0.75 mm <sup>2</sup>	2 x 0.2 - 0.75 mm <sup>2</sup>	
Stripping length	7 mm	7 mm	7 mm	
Approvals	UL/CSA	UL/CSA	UL/CSA	

### Holding clamp

Type	PRSXT C1/2	PRSXT C1/2	PRSXT C1/2	
<b>Cat. no./Qty.</b>	<b>16016.2 / 20</b>	<b>16016.2 / 20</b>	<b>16016.2 / 20</b>	

## Relay 1 CO contact, PRS 1 Z

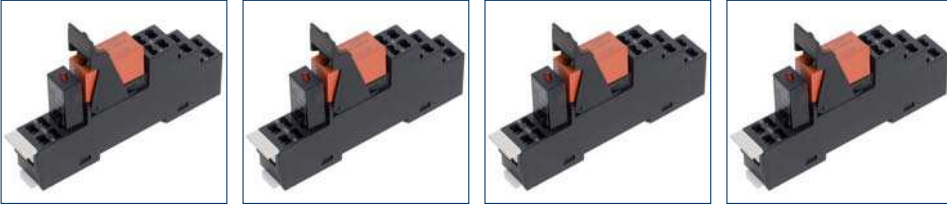
Complete tension-spring connection components	PRSU 1Z/12 V DC	PRSU 1Z/24 V DC	PRSU 1Z/60 V DC	PRSU 1Z/110 V DC
consisting of:				
· Relay				
· Insert module				
· Socket base				
· Holding clamp				
<b>Type</b>	<b>PRSU 1Z/12 V DC</b>	<b>PRSU 1Z/24 V DC</b>	<b>PRSU 1Z/60 V DC</b>	<b>PRSU 1Z/110 V DC</b>
<b>Cat. no./Qty.</b>	<b>15781.2/1</b>	<b>15782.2/1</b>	<b>15783.2/1</b>	<b>15784.2/1</b>
Size (L x W x H) with TS 35	98 x 16.3 x 69.2 mm	98 x 16.3 x 69.2 mm	98 x 16.3 x 69.2 mm	98 x 16.3 x 69.2 mm
Weight	59 g	59 g	59 g	59 g

### Individual components

#### Relay 1 CO, encapsulated design

Type	PRS 1/12 V DC	PRS 1/24 V DC	PRS 1/60 V DC	PRS 1/110 V DC
<b>Cat. no./Qty.</b>	<b>6996.0/1</b>	<b>6804.0/1</b>	<b>15539.2/1</b>	<b>15540.2/1</b>
Weight	15 g	15 g	15 g	15 g
<b>General information</b>	Insulation IEC 664/VDE 0110, rated voltage 250 V, pollution degree 3, overvoltage category III, flammability class UL 94 V-0			
DIN-VDE specifications				
Test voltage coil/contact	5 kV	5 kV	5 kV	5 kV
Pinning	3.5 mm	3.5 mm	3.5 mm	3.5 mm
Operating temperature	-40 to +85°C	-40 to +85°C	-40 to +85°C	-40 to +85°C
Important notes	-	-	-	-
<b>Input data</b>				
Input voltage	12 V DC	24 V DC	60 V DC	110 V DC
Rated power consumption	0.40 W	0.40 W	0.42 W	0.42 W
<b>Output data</b>				
Contacts	1 CO contacts	1 CO contacts	1 CO contacts	1 CO contacts
Switching voltage/Max. switching voltage	240 V AC/400 V AC	240 V AC/400 V AC	240 V AC/400 V AC	240 V AC/400 V AC
Max continuous current/inrush current	12 A/25 A	12 A/25 A	12 A/25 A	12 A/25 A
Typical response time/release time	7 ms/3 ms	7 ms/3 ms	7 ms/3 ms	7 ms/3 ms
Contact material	AgNi 90/10	AgNi 90/10	AgNi 90/10	AgNi 90/10
Electrical service life	1.2 x 10 <sup>3</sup>	1.2 x 10 <sup>3</sup>	1.2 x 10 <sup>3</sup>	1.2 x 10 <sup>3</sup>
At contact load	4 A, 230 V AC	4 A, 230 V AC	4 A, 230 V AC	4 A, 230 V AC
Mechanical life span	> 30 x 10 <sup>6</sup>	> 30 x 10 <sup>6</sup>	> 30 x 10 <sup>6</sup>	> 30 x 10 <sup>6</sup>

### Insert module





Type	PRS LED 24 V DC	PRS LED 24 V DC	PRS LED 110 V DC	PRS LED 110 V DC
<b>Cat. no./Qty.</b>	<b>15141.2/1</b>	<b>15141.2/1</b>	<b>15422.2/1</b>	<b>15422.2/1</b>
Protected against polarity reversal	Status display with free-wheel diode	Status display with free-wheel diode	Status display with free-wheel diode	Status display with free-wheel diode
In parallel to coil	12 to 24 V DC	12 to 24 V DC	60 to 110 V DC	60 to 110 V DC

### Socket base

Type	PRS 1 Z	PRS 1 Z	PRS 1 Z	PRS 1 Z
<b>Cat. no./Qty.</b>	<b>15780.2/1</b>	<b>15780.2/1</b>	<b>15780.2/1</b>	<b>15780.2/1</b>
<b>General</b>				
Mounting foot for DIN rails	TS 35	TS 35	TS 35	TS 35
Plug-in base for	3.5 mm pinning	3.5 mm pinning	3.5 mm pinning	3.5 mm pinning
Connection type	Tension-spring connection	Tension-spring connection	Tension-spring connection	Tension-spring connection
<b>Technical data</b>				
Rated current	12 A	12 A	12 A	12 A
Rated voltage	300 V	300 V	300 V	300 V
Dielectric strength	> 2500 Veff	> 2500 Veff	> 2500 Veff	> 2500 Veff
Insulation group (VDE 0110 b)	C/250 V	C/250 V	C/250 V	C/250 V
Ambient temperature	-25 to +70°C	-25 to +70°C	-25 to +70°C	-25 to +70°C
Protection degree, enclosure	IP 20	IP 20	IP 20	IP 20
Flammability class UL 94	V-0	V-0	V-0	V-0
Touch protection, acc. to	VBG 4	VBG 4	VBG 4	VBG 4
Connection cross-section	2 x 0.2 - 1.5 mm <sup>2</sup>	2 x 0.2 - 1.5 mm <sup>2</sup>	2 x 0.2 - 1.5 mm <sup>2</sup>	2 x 0.2 - 1.5 mm <sup>2</sup>
With ferrule	2 x 0.2 - 0.75 mm <sup>2</sup>	2 x 0.2 - 0.75 mm <sup>2</sup>	2 x 0.2 - 0.75 mm <sup>2</sup>	2 x 0.2 - 0.75 mm <sup>2</sup>
Insulation stripping length	7 mm	7 mm	7 mm	7 mm
Approvals	UL/CSA	UL/CSA	UL/CSA	UL/CSA

### Holding clamp

Type	PRS C 1/2	PRS C 1/2	PRS C 1/2	PRS C 1/2
<b>Cat. no./Qty.</b>	<b>15138.2/1</b>	<b>15138.2/1</b>	<b>15138.2/1</b>	<b>15138.2/1</b>

PRSU 1LZ/24 V DC	PRSU 1Z/24 V AC	PRSU 1Z/115 V AC	PRSU 1Z/230 V AC		
					
<b>PRSU 1LZ/24 V DC</b> <b>15788.2/1</b>	<b>PRSU 1Z/24 V AC</b> <b>15785.2/1</b>	<b>PRSU 1Z/115 V AC</b> <b>15786.2/1</b>	<b>PRSU 1Z/230 V AC</b> <b>15787.2/1</b>		
98 x 16.3 x 69.2 mm	98 x 16.3 x 69.2 mm	98 x 16.3 x 69.2 mm	98 x 16.3 x 69.2 mm		
59 g	59 g	59 g	59 g		

**Individual components**  
**Relay 1 CO, encapsulated design**

PR 1L/24 V DC	PR 1/24 V AC	PR 1/115 V AC	PR 1/230 V AC		
<b>6940.0/1</b>	<b>6480.2/1</b>	<b>15228.2/1</b>	<b>6481.2/1</b>		
15 g	15 g	15 g	15 g		
Insulation IEC 664/VDE 0110, rated voltage 250 V, pollution degree 3, overvoltage category III, flammability class UL 94 V-0					
4 kV	5 kV	5 kV	5 kV		
5 mm	3.5 mm	3.5 mm	3.5 mm		
-20 to +50°C	-40 to +85°C	-40 to +85°C	-40 to +85°C		
Inductive loads	-	-	-		
24 V DC	24 V AC	115 V AC	230 V AC		
0.50 W	0.75 VA	0.75 VA	0.75 VA		
1 CO contacts	1 CO contacts	1 CO contacts	1 CO contacts		
240 V AC	240 V AC/400 V AC	240 V AC/400 V AC	240 V AC/400 V AC		
16 A/80 A (20 ms)	12 A/25 A	12 A/25 A	12 A/25 A		
10 ms/10 ms	7 ms/3 ms	7 ms/3 ms	7 ms/3 ms		
AgSn O2	AgNi 90/10	AgNi 90/10	AgNi 90/10		
1 x 10 <sup>5</sup>	1.2 x 10 <sup>3</sup>	1.2 x 10 <sup>3</sup>	1.2 x 10 <sup>3</sup>		
16 A, 230 V AC	4 A, 230 V AC	4 A, 230 V AC	4 A, 230 V AC		
> 30 x 10 <sup>5</sup>	> 10 x 10 <sup>6</sup>	> 10 x 10 <sup>6</sup>	> 10 x 10 <sup>6</sup>		

**Insert module**

PRS LED 24 V DC	PRS LED 24 V UC	PRS LED 230 V AG	PRS LED 230 V AG		
<b>15141.2/1</b>	<b>15175.2/1</b>	<b>15142.2/1</b>	<b>15142.2/1</b>		
Status display with free-wheel diode	Status display	Status display	Status display		
12 to 24 V DC	12 to 48 V AC/DC	110 to 230 V AC	110 to 230 V AC		





**Socket base**

PR 2 Z	PR 1 Z	PR 1 Z	PR 1 Z		
<b>15789.2/1</b>	<b>15780.2/1</b>	<b>15780.2/1</b>	<b>15780.2/1</b>		
TS 35	TS 35	TS 35	TS 35		
5 mm pinning	3.5 mm pinning	3.5 mm pinning	3.5 mm pinning		
Tension-spring connection	Tension-spring connection	Tension-spring connection	Tension-spring connection		
10 A	12 A	12 A	12 A		
300 V	300 V	300 V	300 V		
> 2500 Veff	> 2500 Veff	> 2500 Veff	> 2500 Veff		
C/250 V	C/250 V	C/250 V	C/250 V		
-25 to +70°C	-25 to +70°C	-25 to +70°C	-25 to +70°C		
IP 20	IP 20	IP 20	IP 20		
V-0	V-0	V-0	V-0		
VBG 4	VBG 4	VBG 4	VBG 4		
2 x 0.2 - 1.5 mm <sup>2</sup>	2 x 0.2 - 1.5 mm <sup>2</sup>	2 x 0.2 - 1.5 mm <sup>2</sup>	2 x 0.2 - 1.5 mm <sup>2</sup>		
2 x 0.2 - 0.75 mm <sup>2</sup>	2 x 0.2 - 0.75 mm <sup>2</sup>	2 x 0.2 - 0.75 mm <sup>2</sup>	2 x 0.2 - 0.75 mm <sup>2</sup>		
7 mm	7 mm	7 mm	7 mm		
UL/CSA	UL/CSA	UL/CSA	UL/CSA		

**Holding clamp**

PR C 1/2	PR C 1/2	PR C 1/2	PR C 1/2		
<b>15138.2/1</b>	<b>15138.2/1</b>	<b>15138.2/1</b>	<b>15138.2/1</b>		

## Relay 2 CO contacts, PRS 2 Z





Complete tension-spring connection components	PRSU 2Z/12 V DC	PRSU 2Z/24 V DC	PRSU 2Z/48 V DC	PRSU 2Z/60 V DC
consisting of:	   			
· Relay				
· Insert module				
· Socket base				
· Holding clamp				
<b>Type</b>	<b>PRSU 2Z/12 V DC</b>	<b>PRSU 2Z/24 V DC</b>	<b>PRSU 2Z/48 V DC</b>	<b>PRSU 2Z/60 V DC</b>
<b>Cat. no./Qty.</b>	<b>15790.2/1</b>	<b>15791.2/1</b>	<b>15792.2/1</b>	<b>15793.2/1</b>
Size (L x W x H) with TS 35	98 x 16.3 x 69.2 mm	98 x 16.3 x 69.2 mm	98 x 16.3 x 69.2 mm	98 x 16.3 x 69.2 mm
Weight	61 g	61 g	61 g	61 g

Individual components				
Relay 2 CO, encapsulated design				
Type	PRS 2/12 V DC	PRS 2/24 V DC	PRS 2/48 V DC	PRS 2/60 V DC
<b>Cat. no./Qty.</b>	<b>6482.2/1</b>	<b>6483.2/1</b>	<b>15334.2/1</b>	<b>15335.2/1</b>
Weight	15 g	15 g	15 g	15 g
<b>General information</b>	Insulation IEC 664/VDE 0110, rated voltage 250 V, pollution degree 3, overvoltage category III, flammability class UL 94 V-0			
DIN-VDE specifications				
Test voltage coil/contact	5 kV	5 kV	5 kV	5 kV
Pinning	5 mm	5 mm	5 mm	5 mm
Operating temperature	-40 to +70°C	-40 to +70°C	-40 to +70°C	-40 to +70°C
<b>Input data</b>				
Input voltage	12 V DC	24 V DC	48 V DC	60 V DC
Rated power consumption	0.40 W	0.40 W	0.40 W	0.40 W
<b>Output data</b>				
Contacts	2 CO contacts	2 CO contacts	2 CO contacts	2 CO contacts
Switching voltage/Max. switching voltage	240 V AC/400 V AC	240 V AC/400 V AC	240 V AC/400 V AC	240 V AC/400 V AC
Max continuous current/inrush current	8 A/15 A	8 A/15 A	8 A/15 A	8 A/15 A
Typical response time/release time	7 ms/2 ms	7 ms/2 ms	7 ms/2 ms	7 ms/2 ms
Contact material	AgNi 90/10	AgNi 90/10	AgNi 90/10	AgNi 90/10
Electrical service life	1.5 x 10 <sup>5</sup>	1.5 x 10 <sup>5</sup>	1.5 x 10 <sup>5</sup>	1.5 x 10 <sup>5</sup>
At contact load	4 A, 230 V AC	4 A, 230 V AC	4 A, 230 V AC	4 A, 230 V AC
Mechanical life span	>30 x 10 <sup>6</sup>	>30 x 10 <sup>6</sup>	>30 x 10 <sup>6</sup>	>30 x 10 <sup>6</sup>

Insert module				
Type	PRS LED 24 V DC	PRS LED 24 V DC	PRS LED 24 V UC	PRS LED 110 V DC
<b>Cat. no./Qty.</b>	<b>15141.2/1</b>	<b>15141.2/1</b>	<b>15175.2/1</b>	<b>15422.2/1</b>
Protected against polarity reversal	Status display with free-wheel diode	Status display with free-wheel diode	Status display	Status display with free-wheel diode
In parallel to coil	12 to 24 V DC	12 to 24 V DC	12 to 48 V AC/DC	60 to 110 V DC

Socket base				
Type	PRS 2 Z	PRS 2 Z	PRS 2 Z	PRS 2 Z
<b>Cat. no./Qty.</b>	<b>15789.2/1</b>	<b>15789.2/1</b>	<b>15789.2/1</b>	<b>15789.2/1</b>
<b>General</b>				
Mounting foot for DIN rails	TS 35	TS 35	TS 35	TS 35
Plug-in base for	5 mm pinning	5 mm pinning	5 mm pinning	5 mm pinning
Connection type	Tension-spring connection	Tension-spring connection	Tension-spring connection	Tension-spring connection
<b>Technical data</b>				
Rated current	10 A	10 A	10 A	10 A
Rated voltage	300 V	300 V	300 V	300 V
Dielectric strength	> 2500 Veff	> 2500 Veff	> 2500 Veff	> 2500 Veff
Insulation group (VDE 0110 b)	C/250 V	C/250 V	C/250 V	C/250 V
Ambient temperature	-25 to +70°C	-25 to +70°C	-25 to +70°C	-25 to +70°C
Protection degree, enclosure	IP 20	IP 20	IP 20	IP 20
Flammability class UL 94	V-0	V-0	V-0	V-0
Touch protection, acc. to	VBG 4	VBG 4	VBG 4	VBG 4
Connection cross-section	2 x 0.2 - 1.5 mm <sup>2</sup>	2 x 0.2 - 1.5 mm <sup>2</sup>	2 x 0.2 - 1.5 mm <sup>2</sup>	2 x 0.2 - 1.5 mm <sup>2</sup>
With ferrule	2 x 0.2 - 0.75 mm <sup>2</sup>	2 x 0.2 - 0.75 mm <sup>2</sup>	2 x 0.2 - 0.75 mm <sup>2</sup>	2 x 0.2 - 0.75 mm <sup>2</sup>
Insulation stripping length	7 mm	7 mm	7 mm	7 mm
Approvals	UL/CSA	UL/CSA	UL/CSA	UL/CSA

Holding clamp				
Type	PRS C 1/2	PRS C 1/2	PRS C 1/2	PRS C 1/2
<b>Cat. no./Qty.</b>	<b>15138.2/1</b>	<b>15138.2/1</b>	<b>15138.2/1</b>	<b>15138.2/1</b>

PRSU 2Z/110 V DC	PRSU 2Z/24 V AC	PRSU 2Z/48 V AC	PRSU 2Z/115 V AC	PRSU 2Z/230 V AC	
					
<b>PRSU 2Z/110 V DC</b> <b>15794.2/1</b>	<b>PRSU 2Z/24 V AC</b> <b>15795.2/1</b>	<b>PRSU 2Z/48 V AC</b> <b>15950.2/1</b>	<b>PRSU 2Z/115 V AC</b> <b>15796.2/1</b>	<b>PRSU 2Z/230 V AC</b> <b>15797.2/1</b>	
98 x 16.3 x 69.2 mm 61 g	98 x 16.3 x 69.2 mm 61 g	98 x 16.3 x 69.2 mm 61 g	98 x 16.3 x 69.2 mm 61 g	98 x 16.3 x 69.2 mm 61 g	

### Individual components

#### Relay 2 CO, encapsulated design

PRS 2/110 V DC	PRS 2/24 V AC	PRS 2/48 V AC	PRS 2/115 V AC	PRS 2/230 V AC	
<b>15541.2/1</b>	<b>6484.2/1</b>	<b>15947.2/1</b>	<b>15229.2/1</b>	<b>6485.2/1</b>	
15 g	15 g	15 g	15 g	15 g	
Insulation IEC 664/VDE 0110, rated voltage 250 V, pollution degree 3, overvoltage category III, flammability class UL 94 V-0					
5 kV	5 kV	5 kV	5 kV	5 kV	
5 mm	5 mm	5 mm	5 mm	5 mm	
-40 to +70°C	-40 to +70°C	-40 to +70°C	-40 to +70°C	-40 to +70°C	
110 V DC	24 V AC	48 V AC	115 V AC	230 V AC	
0.40 W	0.75 VA	0.75 VA	0.75 VA	0.75 VA	
2 CO contacts	2 CO contacts	2 CO contacts	2 CO contacts	2 CO contacts	
240 V AC/400 V AC	240 V AC/400 V AC	240 V AC/400 V AC	240 V AC/400 V AC	240 V AC/400 V AC	
8 A/15 A	8 A/15 A	8 A/15 A	8 A/15 A	8 A/15 A	
7 ms/2 ms	7 ms/2 ms	7 ms/2 ms	7 ms/2 ms	7 ms/2 ms	
AgNi 90/10	AgNi 90/10	AgNi 90/10	AgNi 90/10	AgNi 90/10	
1.5 x 10 <sup>5</sup>	1.5 x 10 <sup>5</sup>	1.5 x 10 <sup>5</sup>	1.5 x 10 <sup>5</sup>	1.5 x 10 <sup>5</sup>	
4 A, 230 V AC	4 A, 230 V AC	4 A, 230 V AC	4 A, 230 V AC	4 A, 230 V AC	
>30 x 10 <sup>6</sup>	>5 x 10 <sup>6</sup>	>5 x 10 <sup>6</sup>	> 5 x 10 <sup>6</sup>	> 5 x 10 <sup>6</sup>	

### Insert module

PRS LED 110 V DC	PRS LED 24 V AC	PRS LED 24 V AC	PRS LED 230 V AC	PRS LED 230 V AC	
<b>15422.2/1</b>	<b>15175.2/1</b>	<b>15175.2/1</b>	<b>15142.2/1</b>	<b>15142.2/1</b>	
Status display with free-wheel diode	Status display	Status display	Status display	Status display	
60 to 110 V DC	12 to 48 V AC/DC	12 to 48 V AC/DC	110 to 230 V AC	110 to 230 V AC	

### Socket base

PRS 2 Z	PRS 2 Z	PRS 2 Z	PRS 2 Z	PRS 2 Z	
<b>15789.2/1</b>	<b>15789.2/1</b>	<b>15789.2/1</b>	<b>15789.2/1</b>	<b>15789.2/1</b>	
TS 35	TS 35	TS 35	TS 35	TS 35	
5 mm pinning	5 mm pinning	5 mm pinning	5 mm pinning	5 mm pinning	
Tension-spring connection	Tension-spring connection	Tension-spring connection	Tension-spring connection	Tension-spring connection	
10 A	10 A	10 A	10 A	10 A	
300 V	300 V	300 V	300 V	300 V	
> 2500 Veff	> 2500 Veff	> 2500 Veff	> 2500 Veff	> 2500 Veff	
C/250 V	C/250 V	C/250 V	C/250 V	C/250 V	
-25 to +70°C	-25 to +70°C	-25 to +70°C	-25 to +70°C	-25 to +70°C	
IP 20	IP 20	IP 20	IP 20	IP 20	
V-0	V-0	V-0	V-0	V-0	
VBG 4	VBG 4	VBG 4	VBG 4	VBG 4	
2 x 0.2-1.5 mm <sup>2</sup>	2 x 0.2-1.5 mm <sup>2</sup>	2 x 0.2-1.5 mm <sup>2</sup>	2 x 0.2-1.5 mm <sup>2</sup>	2 x 0.2-1.5 mm <sup>2</sup>	
2 x 0.2-0.75 mm <sup>2</sup>	2 x 0.2-0.75 mm <sup>2</sup>	2 x 0.2-0.75 mm <sup>2</sup>	2 x 0.2-0.75 mm <sup>2</sup>	2 x 0.2-0.75 mm <sup>2</sup>	
7 mm	7 mm	7 mm	7 mm	7 mm	
UL/CSA	UL/CSA	UL/CSA	UL/CSA	UL/CSA	

### Holding clamp

PRS C 1/2	PRS C 1/2	PRS C 1/2	PRS C 1/2	PRS C 1/2	
<b>15138.2/1</b>	<b>15138.2/1</b>	<b>15138.2/1</b>	<b>15138.2/1</b>	<b>15138.2/1</b>	

## Relay 4 CO contacts, PRS 4 Z







Complete tension-spring connection components		PRSU 4Z/12 V DC	PRSU 4Z/24 V DC	PRSU 4Z/48 V DC	PRSU 4Z/60 V DC
consisting of:					
· Relay					
· Insert module					
· Socket base					
· Holding clamp					
<b>Type</b>		<b>PRSU 4Z/12 V DC</b>	<b>PRSU 4Z/24 V DC</b>	<b>PRSU 4Z/48 V DC</b>	<b>PRSU 4Z/60 V DC</b>
<b>Cat. no./Qty.</b>		<b>15798.2/1</b>	<b>15799.2/1</b>	<b>15800.2/1</b>	<b>15801.2/1</b>
Size (L x W x H) with TS 35		98 x 31 x 69.2 mm	98 x 31 x 69.2 mm	98 x 31 x 69.2 mm	98 x 31 x 69.2 mm
Weight		109 g	109 g	109 g	109 g

Individual components					
Relay 4 CO, encapsulated design					
Type	PRS 4/12 V DC	PRS 4/24 V DC	PRS 4/48 V DC	PRS 4/60 V DC	
<b>Cat. no./Qty.</b>	<b>6486.2/1</b>	<b>6487.2/1</b>	<b>15461.2/1</b>	<b>15336.2/1</b>	
Weight	30 g	30 g	30 g	30 g	
<b>General information</b>	Insulation IEC 664/VDE 0110, rated voltage 250 V, pollution degree 3, overvoltage category III, flammability class UL 94 V-0				
DIN-VDE specifications					
Test voltage coil/contact	2.5 kV	2.5 kV	2.5 kV	2.5 kV	
Operating temperature	-40 to +70°C	-40 to +70°C	-40 to +70°C	-40 to +70°C	
<b>Input data</b>					
Input voltage	12 V DC	24 V DC	48 V DC	60 V DC	
Rated power consumption	0.75 W	0.75 W	0.75 W	0.75 W	
<b>Output data</b>					
Contacts	4 CO contacts	4 CO contacts	4 CO contacts	4 CO contacts	
Switching voltage/Max. switching voltage	240 V AC/240 V AC	240 V AC/240 V AC	240 V AC/240 V AC	240 V AC/240 V AC	
Max continuous current/inrush current	6 A/12 A	6 A/12 A	6 A/12 A	6 A/12 A	
Typical response time/release time	15 ms/10 ms	15 ms/10 ms	15 ms/10 ms	15 ms/10 ms	
Contact material	AgNi 90/10	AgNi 90/10	AgNi 90/10	AgNi 90/10	
Electrical service life	1.5 x 10 <sup>5</sup>	1.5 x 10 <sup>5</sup>	1.5 x 10 <sup>5</sup>	1.5 x 10 <sup>5</sup>	
At contact load	6 A, 240 V AC	6 A, 240 V AC	6 A, 240 V AC	6 A, 240 V AC	
Mechanical life span	>30 x 10 <sup>6</sup>	>30 x 10 <sup>6</sup>	>30 x 10 <sup>6</sup>	>30 x 10 <sup>6</sup>	

Insert module					
Type	PRS LED 24 V DC	PRS LED 24 V DC	PRS LED 24 V UC	PRS LED 110 V DC	
<b>Cat. no./Qty.</b>	<b>15141.2/1</b>	<b>15141.2/1</b>	<b>15175.2/1</b>	<b>15422.2/1</b>	
Protected against polarity reversal	Status display with free-wheel diode	Status display with free-wheel diode	Status display	Status display with free-wheel diode	
In parallel to coil	12 to 24 V DC	12 to 24 V DC	12 to 48 V AC/DC	60 to 110 V DC	

Socket base					
Type	PRS 4 Z	PRS 4 Z	PRS 4 Z	PRS 4 Z	
<b>Cat. no./Qty.</b>	<b>15431.2/1</b>	<b>15431.2/1</b>	<b>15431.2/1</b>	<b>15431.2/1</b>	
<b>General</b>					
Mounting foot for DIN rails	TS 35	TS 35	TS 35	TS 35	
Plug-in base for	2.8 mm fast-on	2.8 mm fast-on	2.8 mm fast-on	2.8 mm fast-on	
Connection type	Tension-spring connection	Tension-spring connection	Tension-spring connection	Tension-spring connection	
<b>Technical data</b>					
Rated current	12 A	12 A	12 A	12 A	
Rated voltage	300 V	300 V	300 V	300 V	
Dielectric strength	> 2500 Veff	> 2500 Veff	> 2500 Veff	> 2500 Veff	
Insulation group (VDE 0110 b)	C/250 V	C/250 V	C/250 V	C/250 V	
Ambient temperature	-25 to +70°C	-25 to +70°C	-25 to +70°C	-25 to +70°C	
Protection degree, enclosure	IP 20	IP 20	IP 20	IP 20	
Flammability class UL 94	V-0	V-0	V-0	V-0	
Touch protection, acc. to	VBG 4	VBG 4	VBG 4	VBG 4	
Connection cross-section	2 x 0.2 - 1.5 mm <sup>2</sup>	2 x 0.2 - 1.5 mm <sup>2</sup>	2 x 0.2 - 1.5 mm <sup>2</sup>	2 x 0.2 - 1.5 mm <sup>2</sup>	
With ferrule	2 x 0.2 - 0.75 mm <sup>2</sup>	2 x 0.2 - 0.75 mm <sup>2</sup>	2 x 0.2 - 0.75 mm <sup>2</sup>	2 x 0.2 - 0.75 mm <sup>2</sup>	
Insulation stripping length	7 mm	7 mm	7 mm	7 mm	
Approvals	UL/CSA	UL/CSA	UL/CSA	UL/CSA	

Holding clamp					
Type	PRS C 4	PRS C 4	PRS C 4	PRS C 4	
<b>Cat. no./Qty.</b>	<b>15140.2/1</b>	<b>15140.2/1</b>	<b>15140.2/1</b>	<b>15140.2/1</b>	

PRSU 4Z/110 V DC	PRSU 4Z/220 V DC	PRSU 4Z/12 V AC	PRSU 4Z/24 V AC	PRSU 4Z/115 V AC	PRSU 4Z/230 V AC
					
<b>PRSU 4Z/110 V DC</b> <b>15802.2/1</b>	<b>PRSU 4Z/220 V DC</b> <b>15803.2/1</b>	<b>PRSU 4Z/12 V AC</b> <b>15804.2/1</b>	<b>PRSU 4Z/24 V AC</b> <b>15805.2/1</b>	<b>PRSU 4Z/115 V AC</b> <b>15806.2/1</b>	<b>PRSU 4Z/230 V AC</b> <b>15807.2/1</b>
98 x 31 x 69.2 mm	98 x 31 x 69.2 mm	98 x 31 x 69.2 mm	98 x 31 x 69.2 mm	98 x 31 x 69.2 mm	98 x 31 x 69.2 mm
109 g	109 g	109 g	109 g	109 g	109 g

### Individual components

#### Relay 4 CO, encapsulated design

PRS 4/110 V DC	PRS 4/220 V DC	PRS 4/12 V AC	PRS 4/24 V UC	PRS 4/115 V AC	PRS 4/230 V AC
<b>15542.2/1</b>	<b>15368.2/1</b>	<b>15393.2/1</b>	<b>6488.2/1</b>	<b>15257.2/1</b>	<b>6489.2/1</b>
30 g	30 g	30 g	30 g	30 g	30 g
Insulation IEC 664/VDE 0110, rated voltage 250 V, pollution degree 3, overvoltage category III, flammability class UL 94 V-0					
2.5 kV	2.5 kV	2.5 kV	2.5 kV	2.5 kV	2.5 kV
-40 to +70°C	-40 to +70°C	-40 to +70°C	-40 to +70°C	-40 to +70°C	-40 to +70°C
110 V DC	220 V DC	12 V AC	24 V AC	115 V AC	230 V AC
0.75 W	0.75 W	1.0 VA	1.0 VA	1.0 VA	1.0 VA
4 CO contacts	4 CO contacts	4 CO contacts	4 CO contacts	4 CO contacts	4 CO contacts
240 V AC/240 V AC	240 V AC/240 V AC	240 V AC/240 V AC	240 V AC/240 V AC	240 V AC/240 V AC	240 V AC/240 V AC
6 A/12 A	6 A/12 A	6 A/12 A	6 A/12 A	6 A/12 A	6 A/12 A
15 ms/10 ms	15 ms/10 ms	15 ms/10 ms	15 ms/10 ms	15 ms/10 ms	15 ms/10 ms
AgNi 90/10	AgNi 90/10	AgNi 90/10	AgNi 90/10	AgNi 90/10	AgNi 90/10
1.5 x 10 <sup>5</sup>	1.5 x 10 <sup>5</sup>	1.5 x 10 <sup>5</sup>	1.5 x 10 <sup>5</sup>	1.5 x 10 <sup>5</sup>	1.5 x 10 <sup>5</sup>
6 A, 240 V AC	6 A, 240 V AC	6 A, 240 V AC	6 A, 240 V AC	6 A, 240 V AC	6 A, 240 V AC
>30 x 10 <sup>6</sup>	>30 x 10 <sup>6</sup>	>20 x 10 <sup>6</sup>	>20 x 10 <sup>6</sup>	>20 x 10 <sup>6</sup>	>20 x 10 <sup>6</sup>

### Insert module

PRS LED 110 V DC	PRS LED 230 V AC	PRS LED 24 V UC	PRS LED 24 V UC	PRS LED 230 V AC	PRS LED 230 V AC
<b>15422.2/1</b>	<b>15142.2/1</b>	<b>15175.2/1</b>	<b>15175.2/1</b>	<b>15142.2/1</b>	<b>15142.2/1</b>
Status display with free-wheel diode	Status display	Status display	Status display	Status display	Status display
60 to 110 V DC	110 to 230 V AC	12 to 48 V AC/DC	12 to 48 V AC/DC	110 to 230 V AC	110 to 230 V AC

### Socket base

PRS 4 Z	PRS 4 Z	PRS 4 Z	PRS 4 Z	PRS 4 Z	PRS 4 Z
<b>15431.2/1</b>	<b>15431.2/1</b>	<b>15431.2/1</b>	<b>15431.2/1</b>	<b>15431.2/1</b>	<b>15431.2/1</b>
TS 35	TS 35	TS 35	TS 35	TS 35	TS 35
2.8 mm fast-on	2.8 mm fast-on	2.8 mm fast-on	2.8 mm fast-on	2.8 mm fast-on	2.8 mm fast-on
Tension-spring connection	Tension-spring connection	Tension-spring connection	Tension-spring connection	Tension-spring connection	Tension-spring connection
12 A	12 A	12 A	12 A	12 A	12 A
300 V	300 V	300 V	300 V	300 V	300 V
> 2500 Veff	> 2500 Veff	> 2500 Veff	> 2500 Veff	> 2500 Veff	> 2500 Veff
C/250 V	C/250 V	C/250 V	C/250 V	C/250 V	C/250 V
-25 to +70°C	-25 to +70°C	-25 to +70°C	-25 to +70°C	-25 to +70°C	-25 to +70°C
IP 20	IP 20	IP 20	IP 20	IP 20	IP 20
V-0	V-0	V-0	V-0	V-0	V-0
VBG 4	VBG 4	VBG 4	VBG 4	VBG 4	VBG 4
2 x 0.2-1.5 mm <sup>2</sup>	2 x 0.2-1.5 mm <sup>2</sup>	2 x 0.2-1.5 mm <sup>2</sup>	2 x 0.2-1.5 mm <sup>2</sup>	2 x 0.2-1.5 mm <sup>2</sup>	2 x 0.2-1.5 mm <sup>2</sup>
2 x 0.2-0.75 mm <sup>2</sup>	2 x 0.2-0.75 mm <sup>2</sup>	2 x 0.2-0.75 mm <sup>2</sup>	2 x 0.2-0.75 mm <sup>2</sup>	2 x 0.2-0.75 mm <sup>2</sup>	2 x 0.2-0.75 mm <sup>2</sup>
7 mm	7 mm	7 mm	7 mm	7 mm	7 mm
UL/CSA	UL/CSA	UL/CSA	UL/CSA	UL/CSA	UL/CSA

### Holding clamp

PRS C 4	PRS C 4	PRS C 4	PRS C 4	PRS C 4	PRS C 4
<b>15140.2/1</b>	<b>15140.2/1</b>	<b>15140.2/1</b>	<b>15140.2/1</b>	<b>15140.2/1</b>	<b>15140.2/1</b>

## Auto-Off-On Relay RM/HA/24 VUC

- Mount on TS 35
- Installation design, width 11.2 mm
- IP 20 protection
- Screw connections protected against accidental contact, according to VBG 4
- Switch for HAND/OFF/AUTOMATIC operation
- LED for indicating the switching status
- Basic insulation, according to VDE 0435/EN 61810-1

### RM/HA/24 VUC



### Dimensions

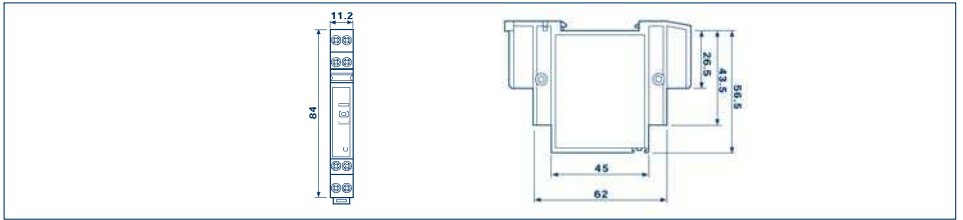

<b>Type</b>	<b>RM/HA/24 VUC</b>	
<b>Cat. no./Qty.</b>	<b>15561.2/1</b>	
Size (L x W x H) with TS 35 x 7.5	84 x 11.2 x 64 mm	
Weight	45 g	
<b>General information</b>		
<b>Insulation properties</b>	DIN EN 50178; DIN VDE 0110, pollution degree 2, overvoltage category III	
DIN-VDE specifications	4 kV	
Dielectric strength of coil/contacts (1.2/50 μs)	3,000 V AC	
Dielectric strength between mains voltage and contacts	1000 V AC	
with open contact	-10 to +50°C	
Operating temperature	IP 20	
Relay protection type	7 mm	
Relay stripping length	solid core	
Max. connection cross-section for screw-clamp	mm <sup>2</sup>	stranded
	1 x 6/2 x 2.5	1 x 4/2 x 1.5
	AWG	1 x 10/2 x 14
		1 x 12/2 x 16
Torque	0.5 Nm	
Ambient heat dissipation without contact current	0.4 W	
with continuous current	1.8 W	
<b>Coil input data</b>		
Rated voltage (UN)	24 V AC/DC	
Power rating AC/DC	0.6 VA (50 Hz) / 0.4 W	
Operating range	19.2 V to 26.4 V AC/DC	
<b>Contacts output data</b>		
Number of contacts	1 CO contact	
Max continuous current/max inrush current	10 A/15 A	
Rated voltage/max. switching voltage	250/400 V AC	
Max. power rating AC 1	2500 VA	
Max. power rating AC 15 (230 V AC)	500 VA	
1-phase motor load, AC 3 - operation (230 V AC)	0.44 kW	
Max. switching current DC 1: 30/110/220 V	10 A/0.3 A/0.12 A	
Min. switching load	300 mW (5 V/5 mA)	
Contact material	AgSnO 2	
Mechanical life span	10 x 10 <sup>6</sup> switching cycles	
Electrical life span AC 1	100 x 10 <sup>3</sup> switching cycles	
<b>Contact data</b>		
Permissible contact load of glow lamps (230 V)	1000 W	
Fluorescent lamps, compensated (230 V)	350 W	
Fluorescent lamps, uncompensated (230 V)	500 W	
Halogen lamps (230 V)	1000 W	

# Auto-Off-On Relay RM/HA/24 VUC

## Circuit diagram

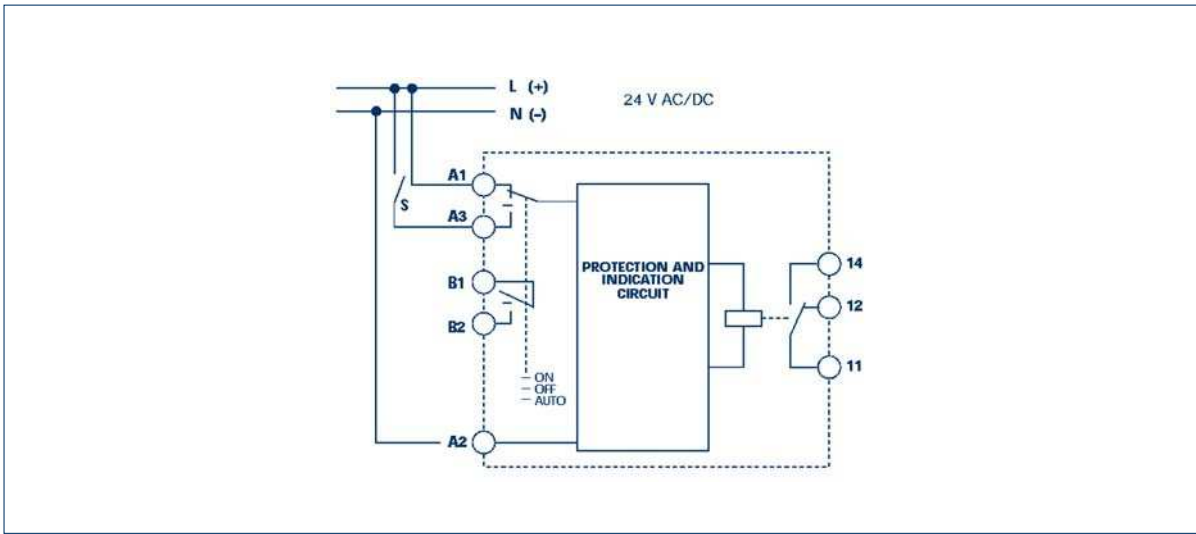

## Table of functions

Changeover contact	Controller output (S)	Output relay	LED	B 1 - B 2 check-back contact
AUTO	Closed	ON	ON	Closed
AUTO	Open	OFF	OFF	Closed
ON	-	ON	ON	Open
OFF	-	OFF	OFF	Open

## Functional principle

When the changeover contact is in the AUTO position, the check-back contact B1-B2 is closed.  
The LED is lit when the NO of the internal relay is closed.

- AUTO = The output signal originating from the controller will be forwarded
- OFF = The actuator for restricting the control variable is turned off
- ON = The actuator for restricting the control variable is turned on independent from the controller

## Opto-couplers | Solid-State

The unambiguous and secure separation of potentials in the different data and control signals - this is important for the trouble-free functioning of equipment and production facilities. The opto-coupler is to an increasing degree responsible for the coupling between sensor and controls, or controls and actuators.

The opto-coupler offers several other advantages over mechanical relay couplers, in addition to the electrical isolation of input and output circuits. This includes a high switching frequency, a high repetition accuracy, a long life span, and resistance to shock.

**CONTA-CLIP** offers opto-couplers in a variety of voltages and power ranges. In order to suit industrial applications, these modules and components are provided with the appropriate protective input circuitry.

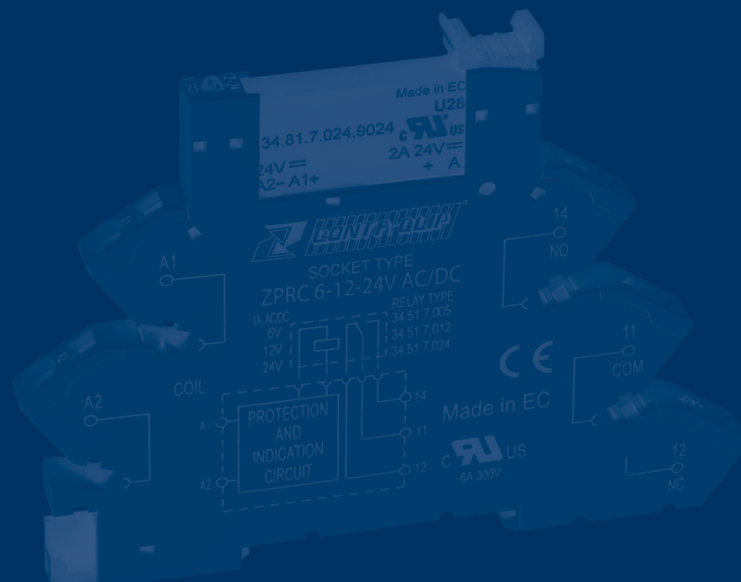



### Solid-state compact PSC

The **PSC** solid-state compact distinguishes itself by its compact shape in the terminal block design. Thanks to their thin form (6.2 mm) and a switchable continuous current of 2 amps, these solid-state modules can be integrated into a mounted-rail control design where space is tight. And owing to their features of secure electrical isolation of circuits and the multiplication of contacts, these modules are well-suited for use in automation engineering. The solid-state components offer a total of 8 varieties, including screw and tension-spring, and are available with input voltages from 24 to 60 VDC and 240 VAC. With the AQI cross-connection system, mutual potentials can be carried out over the coil or contact sides. Excellent equipment identification is possible since the socket base has a labelling surface for the standard PMC BSTR 6/30 marking system. **CONTA-CLIP** also offers a customer-specific labelling service, in addition to the standard marking.



### Solid state relay modules CMS-SSR

The **CMS-SSR** two-way solid state relay module has universal AC / DC inputs and outputs that mean every possible combinations is achievable. The voltage drop to the outputs is extremely low, even at maximum operating load. Resulting in minimal heating in the local environment. Both channels of the module are identical and have a yellow LED to indicate the switch status.

# Solid-state compact PSC

## Solid-state terminals

### 1. Overview

**a Labelling | Marking**  
The socket bases have a labelling surface which is optimally suited for our **PMC Pocket-Maxicard** standard marking systems. In addition to our large variety of standard labels, **CONTA-CLIP** can also provide "just-in-time" individual labelling for you.



**b Using the mount/dismount lever**  
The mounting and dismounting mechanism forms a reliable connection by latching the relay with the socket base. The fitted relay can be removed, easily and without force, from the socket base by using the dismount function of the lever!



**c Pluggable solid-state modules**  
Solid-state modules are also available with various input and output voltages to fit your individual requirements!



#### Converting switching relays to solid-state modules

Relay terminals can be later converted to solid-state terminal, in cases of high expected electrical life spans and in order to avoid the influence of contact-material migration (with DC).

Socket base	Input	Output	Solid-state relays
ZPRC 6-12-24V DC	24V DC	2A 24V DC	PSC 1/24V/DC-24V/2A/DC
ZPRC 60V DC	60V DC	2A 24V DC	PSC 1/60V/DC-24V/2A/DC
ZPRC 230V AC	230V AC	2A 24V DC	PSC 1/60V/DC-24V/2A/DC
ZPRC LW 230V AC	230V AC	2A 24V DC	PSC 1/60V/DC-24V/2A/DC
ZPRC 6-12-24V DC	24V DC	2A 230V AC	PSC 1/24V/DC-240V/2A/AC
ZPRC 60V DC	60V DC	2A 230V AC	PSC 1/60V/DC-240V/2A/AC
ZPRC 230V AC	230V AC	2A 230V AC	PSC 1/60V/DC-240V/2A/AC
ZPRC LW 230V AC	230V AC	2A 230V AC	PSC 1/60V/DC-240V/2A/AC
PRC 6-12-24V DC	24V DC	2A 24V DC	PSC 1/24V/DC-24V/2A/DC
PRC 60V DC	60V DC	2A 24V DC	PSC 1/60V/DC-24V/2A/DC
PRC 230V AC	230V AC	2A 24V DC	PSC 1/60V/DC-24V/2A/DC
PRC LW 230V AC	230V AC	2A 24V DC	PSC 1/60V/DC-24V/2A/DC
PRC 6-12-24V DC	24V DC	2A 230V AC	PSC 1/24V/DC-240V/2A/AC
PRC 60V DC	60V DC	2A 230V AC	PSC 1/60V/DC-240V/2A/AC
PRC 230V AC	230V AC	2A 230V AC	PSC 1/60V/DC-240V/2A/AC
PRC LW 230V AC	230V AC	2A 230V AC	PSC 1/60V/DC-240V/2A/AC

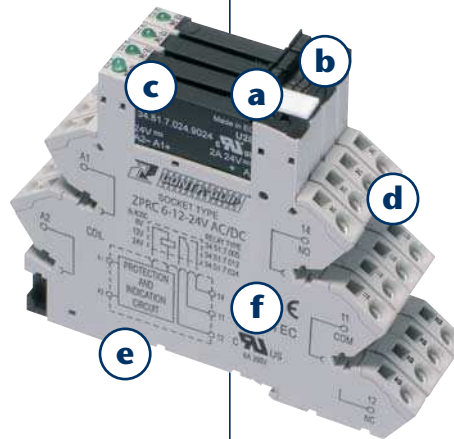

**d Pluggable external cross-connections**  
The AQI/PRC pluggable cross-connection system enables a time-saving distribution of potentials. The AQI/PRC is constructed so that it is protected against accidental touch. It is available as a 20-pole unit, in either yellow, blue or black. The cross-connector can be shortened to fewer poles in order to fit the required interface. Insulation plating can be used to insulate the ends.



**e Mounts on standard TS 35 rail**  
**CONTA-CLIP** relay terminals can be flexibly mounted on standard TS 35 mounting rails, according to EN 50035 and EN 50022.

**f Connection types**  
All of our relay terminals are optionally available with screw or tension-spring connection systems.

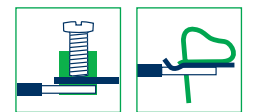

### 2. Approvals (Details upon request.)



# Solid-state compact PSC

## Solid-state terminals

### 3. Features

#### I. Solid-state module

- 5 mm width, very thin solid-state module, semi-conductor relay
- For DC or AC loads, without contact-material erosion
- For high numbers of switching cycles

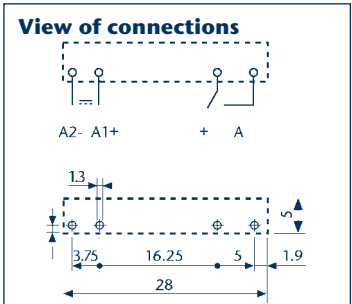
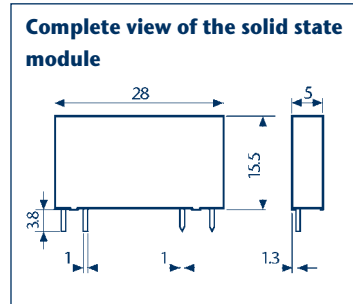

#### II. Socket base

- Mount on TS 35
- Very flexible and modular construction of individual solid-state module base
- User-friendly, because the solid-state modules can be easily replaced
- High-quality connecting terminals (tension-spring or screw connection system)
- Integrated EMC input circuitry, and LED
- High-quality innovative mount/dismount lever
- All versions are optionally available with screw or tension-spring connection system

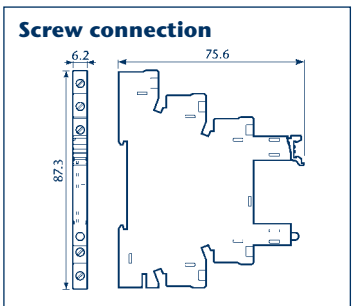
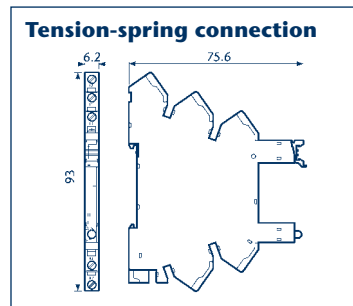

### 4. Specifications

#### Opto-coupler, semi-conductor relay, SSR

##### Additional data

Ambient heat dissipation	without output current W	0.2... 0.5 at ZPRCU LW 1/240 V DC and PRCU LW 1/240 V DC
	at rated output current W	0.4... 0.9 at ZPRCU LW 1/240 V DC and PRCU LW 1/240 V DC

### 5. Input specification

#### DC version

Rated voltage	Input code	Operating range		Drop-out voltage	Rated current	Power rating
$U_N$ V		$U_{min}$ V	$U_{max}$ V	U V	I mA	P W
24	–	16.8	30	10	10.5	–
230... 240 AC	–	184	264	72	5.6 (*)	0.5 (*)

\* Rated current and power at  $U_N = 240$  V.

### 6. Output specification

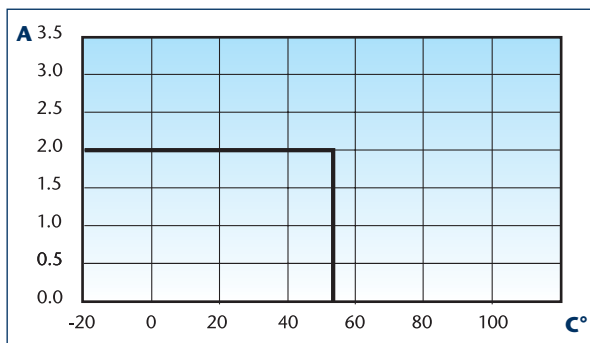

Continuous current, dependent on the ambient temperature. SSR with 2 A, DC or AC

## Solid-state compact PSC

### Solid-state terminals, screw-connection

- consisting of:
  - A basic terminal and a pluggable solid state module
  - Mount on TS 35

### Circuit diagram

- Internal EMC coil circuitry and LED display

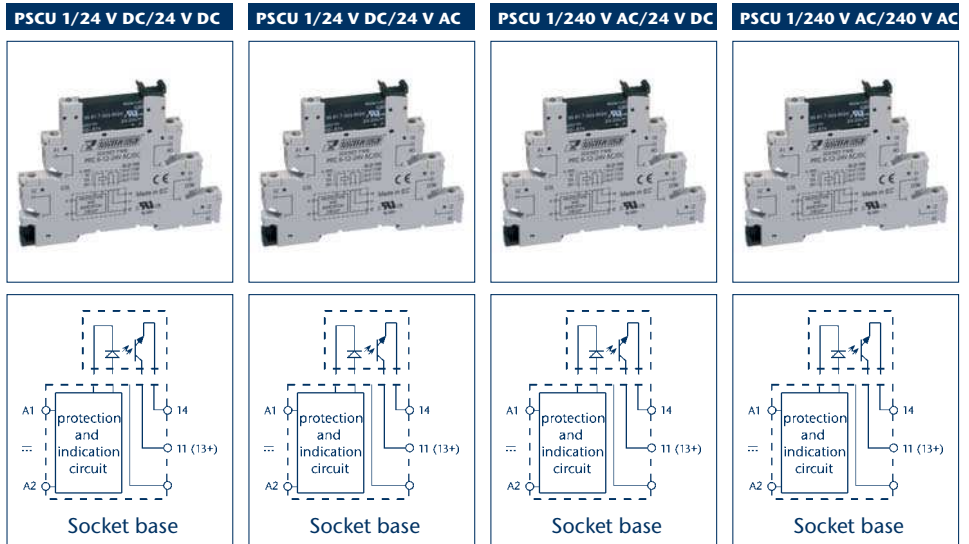

Type	PSCU 1/24 V DC/24 V DC	PSCU 1/24 V DC/240 V AC	PSCU 1/240 V AC/24 V DC	PSCU 1/240 V AC/240 V AC
<b>Cat. no./Qty.</b> Type/Colour grey (RAL 7032)	<b>15530.2/10</b>	<b>15529.2/10</b>	<b>15532.2/10</b>	<b>15531.2/10</b>
Size (L x W x H) with TS 35 x 7.5	87.3 x 6.2 x 79.9 mm	87.3 x 6.2 x 79.9 mm	87.3 x 6.2 x 79.9 mm	87.3 x 6.2 x 79.9 mm
Weight	36 g	36 g	36 g	36 g
Rated operating voltage	24 V DC	24 V DC	230 V AC	230 V AC
<b>General information</b>				
Response time/Release time	0.1/0.4 ms	12/12 ms	0.1/0.4 ms	12/12 ms
Dielectric strength of control/load circuit	2,500 V	2,500 V	2,500 V	2,500 V
Ambient temperature	-20 to +55 °C	-20 to +55 °C	-20 to +55 °C	-20 to +55 °C
Relay protection type	RT III	RT III	RT III	RT III
<b>Ratings for socket base</b>				
Ambient temperature	-20 to +55 °C	-20 to +55 °C	-20 to +55 °C	-20 to +55 °C
Insulation stripping length	10 mm	10 mm	10 mm	10 mm
Max. connection cross-section, solid   flexible	1 x 2.5   1 x 2.5 mm <sup>2</sup> 1 x 14   1 x 14 mm <sup>2</sup>	1 x 2.5   1 x 2.5 mm <sup>2</sup> 1 x 14   1 x 14 mm <sup>2</sup>	1 x 2.5   1 x 2.5 mm <sup>2</sup> 1 x 14   1 x 14 mm <sup>2</sup>	1 x 2.5   1 x 2.5 mm <sup>2</sup> 1 x 14   1 x 14 mm <sup>2</sup>
<b>Input circuit</b>				
Rated voltage	24 V DC	24 V DC	230 V DC	230 V DC
Power rating	0.2 W	0.2 W	0.9 W	0.9 W
Operating range	16 to 30 V DC	16 to 30 V DC	184 to 264 V DC	184 to 264 V DC
Control current	10.5 mA DC	10.5 mA DC	5.6 mA DC	5.6 mA DC
Drop-out voltage	10 AC/DC	10 AC/DC	20 AC/DC	20 AC/DC
Input resistance	3,200 Ω	3,200 Ω	21,300 Ω	21,300 Ω
<b>Ratings for solid-state module</b> combined with socket base				
<b>Output circuit</b>				
Output	1 NO contact	1 NO contact	1 NO contact	1 NO contact
Max. continuous current Max. inrush current (10ms)	2/20 A	2/40 A	2/20 A	2/40 A
Rated voltage   Max. reverse voltage	(24/33) V AC DC	(240/275) V AC	(24/33) V AC DC	(240/275) V AC
Switching load-voltage range	1.5 to 24 V DC	12 to 240 V AC	1.5 to 24 V DC	12 to 240 V AC
Min. switching current	1 mA	22 mA	1 mA	22 mA
Max. residual current at 55 °C	0.001 mA	1.5 mA	0.001 mA	1.5 mA
Max. voltage drop at 20 °C and rated current	0.12 V	1.6 V	0.12 V	1.6 V
<b>Individual components, socket base</b>				
Type/Colour grey (RAL 7032)	<b>PRC 6-12-24 V DC</b>	<b>PRC 6-12-24 V DC</b>	<b>PRC 220 ... 240 V AC/DC</b>	<b>PRC 220 ... 240 V AC/DC</b>
<b>Cat. no./Qty.</b>	<b>15490.2/10</b>	<b>15490.2/10</b>	<b>15489.2/10</b>	<b>15489.2/10</b>
<b>Individual components, solid-state module</b>				
Type/colour	<b>PSC 1/24 V DC-240 V/2 A/DC</b>	<b>PSC 1/24 V DC-240 V/2 A/AC</b>	<b>PSC 1/60 V DC-24 V/2 A/DC</b>	<b>PSC 1/60 V/DC-240 V/2 A/AC</b>
<b>Cat. no./Qty.</b>	<b>15505.2/10</b>	<b>15504.2/10</b>	<b>15507.2/10</b>	<b>15506.2/10</b>
<b>Accessories</b> AQI/PRC external insulated cross-connector	<b>AQI/PRC/20</b>	<b>AQI/PRC/20</b>	<b>AQI/PRC/20</b>	<b>AQI/PRC/20</b>
<b>Cat. no./Qty.</b> yellow	<b>15545.8/1</b>	<b>15545.8/1</b>	<b>15545.8/1</b>	<b>15545.8/1</b>
<b>Cat. no./Qty.</b> blue	<b>15545.5/1</b>	<b>15545.5/1</b>	<b>15545.5/1</b>	<b>15545.5/1</b>
<b>Cat. no./Qty.</b> black	<b>15545.4/1</b>	<b>15545.4/1</b>	<b>15545.4/1</b>	<b>15545.4/1</b>
<b>TW/PRC partition</b>	<b>TW/PRC</b>	<b>TW/PRC</b>	<b>TW/PRC</b>	<b>TW/PRC</b>
<b>Cat. no./Qty.</b>	<b>15546.2/1</b>	<b>15546.2/1</b>	<b>15546.2/1</b>	<b>15546.2/1</b>
<b>PMC labelling/markers</b>	<b>PMC BSTR 6/30</b>	<b>PMC BSTR 6/30</b>	<b>PMC BSTR 6/30</b>	<b>PMC BSTR 6/30</b>
<b>Cat. no./Qty.</b> , standard print, see catalog	CONTA-CONNECT	CONTA-CONNECT	CONTA-CONNECT	CONTA-CONNECT
<b>Cat. no./Qty.</b> neutral	<b>9106.7/300</b>	<b>9106.7/300</b>	<b>9106.7/300</b>	<b>9106.7/300</b>
<b>Cat. no./Qty.</b> , special print	<b>9107.7/300</b>	<b>9107.7/300</b>	<b>9107.7/300</b>	<b>9107.7/300</b>
<b>SDB screwdriver</b>	<b>SDB 0.6 x 3.5</b>	<b>SDB 0.6 x 3.5</b>	<b>SDB 0.6 x 3.5</b>	<b>SDB 0.6 x 3.5</b>
<b>Cat. no./Qty.</b>	<b>1086.0/1</b>	<b>1086.0/1</b>	<b>1086.0/1</b>	<b>1086.0/1</b>

# Solid-state compact PSC

**Solid-state terminals, tension-spring connection**    **ZPSCU 1/24 V DC/24 V DC**    **ZPSCU 1/24 V DC/240 V AC**    **ZPSCU 1/240 V AC/24 V DC**    **ZPSCU 1/240 V AC/240 V AC**

consisting of:

- A basic terminal and a pluggable solid state module
- Mount on TS 35



**Circuit diagram**

- Internal EMC coil circuitry and LED display

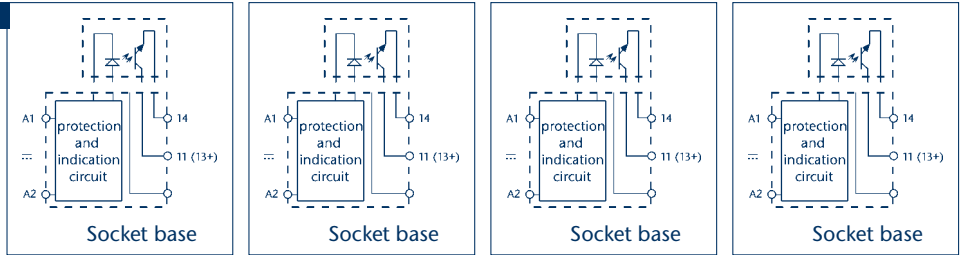

Type	ZPSCU 1/24 V DC/24 V DC	ZPSCU 1/24 V DC/240 V DC	ZPSCU 1/240 V AC/24 V DC	ZPSCU 1/240 V AC/240 V AC
<b>Cat. no./Qty.</b> Type/Colour grey (RAL 7032)	<b>15534.2/10</b>	<b>15533.2/10</b>	<b>15543.2/10</b>	<b>15535.2/10</b>
Size (L x W x H) with TS 35 x 7.5	93 x 6.2 x 79.9 mm	93 x 6.2 x 79.9 mm	93 x 6.2 x 79.9 mm	93 x 6.2 x 79.9 mm
Weight	36 g	36 g	36 g	36 g
Rated operating voltage	24 V DC	24 V DC	230 V AC	230 V AC
<b>General information</b>				
Response time/Release time	0.1/0.4 ms	12/12 ms	0.1/0.4 ms	12/12 ms
Dielectric strength of control/load circuit	2,500 V	2,500 V	2,500 V	2,500 V
Ambient temperature	-20 to +55 °C	-20 to +55 °C	-20 to +55 °C	-20 to +55 °C
Relay protection type	RT III	RT III	RT III	RT III
<b>Ratings for socket base</b>				
Ambient temperature	-20 to +55 °C	-20 to +55 °C	-20 to +55 °C	-20 to +55 °C
Insulation stripping length	10 mm	10 mm	10 mm	10 mm
Max. connection cross-section, solid   flexible	1 x 2.5/2 x 1.5   1 x 2.5/2 x 1.5	1 x 2.5/2 x 1.5   1 x 2.5/2 x 1.5	1 x 2.5/2 x 1.5   1 x 2.5/2 x 1.5	1 x 2.5/2 x 1.5   1 x 2.5/2 x 1.5
	mm <sup>2</sup>			
	AWG			
	1 x 14/2 x 16   1 x 14/2 x 16	1 x 14/2 x 16   1 x 14/2 x 16	1 x 14/2 x 16   1 x 14/2 x 16	1 x 14/2 x 16   1 x 14/2 x 16
<b>Input circuit</b>				
Rated voltage	24 V DC	24 V DC	230 V DC	230 V DC
Power rating	0.2 W	0.2 W	0.9 W	0.9 W
Operating range	16 to 30 V DC	16 to 30 V DC	184 to 264 V DC	184 to 264 V DC
Control current	10.5 mA DC	10.5 mA DC	5.6 mA DC	5.6 mA DC
Drop-out voltage	10 V DC	10 V DC	72 V DC	72 V DC
Input resistance	3200 Ω	3200 Ω	43,000 Ω	43,000 Ω
<b>Ratings for solid-state module</b> combined with socket base				
<b>Output circuit</b>				
Output	1 NO contact	1 NO contact	1 NO contact	1 NO contact
Max. continuous current Max. inrush current (10ms)	2/20 A	2/40 A	2/20 A	2/40 A
Rated voltage   Max. reverse voltage	(24/33) V AC DC	(240/275) V AC	(24/33) V AC DC	(240/275) V AC
Switching load-voltage range	1.5 to 24 V DC	12 to 240 V AC	1.5 to 24 V DC	12 to 240 V AC
Min. switching current	1 mA	22 mA	1 mA	22 mA
Max. residual current at 55°C	0.001 mA	1.5 mA	0.001 mA	1.5 mA
Max. voltage drop at 20°C and rated current	0.12 V	1.6 V	0.12 V	1.6 V

**Individual components, socket base**

Type/Colour grey (RAL 7032)	ZPRC 6-12-24 V DC	ZPRC 6-12-24 V DC	ZPRC 220 ... 240 V AC/DC	ZPRC 220 ... 240 V AC/DC
<b>Cat. no./Qty.</b>	<b>15494.2/10</b>	<b>15494.2/10</b>	<b>15493.2/10</b>	<b>15493.2/10</b>

**Individual components, solid-state module**

Type/Colour	PSC 1/24 V DC-24 V/2 A/DC	PSC 1/24 V DC-240 V/2A/AC	PSC 1/60 V/DC-24 V/2A/DC	PSC 1/60 V/DC-240 V/2A/AC
<b>Cat. no./Qty.</b>	<b>15505.2/10</b>	<b>15504.2/10</b>	<b>15507.2/10</b>	<b>15506.2/10</b>

**Accessories** AQI/PRC external insulated cross-connector

AQI/PRC/20	AQI/PRC/20	AQI/PRC/20	AQI/PRC/20
<b>Cat. no./Qty.</b> yellow	<b>15545.8/1</b>	<b>15545.8/1</b>	<b>15545.8/1</b>
<b>Cat. no./Qty.</b> blue	<b>15545.5/1</b>	<b>15545.5/1</b>	<b>15545.5/1</b>
<b>Cat. no./Qty.</b> black	<b>15545.4/1</b>	<b>15545.4/1</b>	<b>15545.4/1</b>

**TW/PRC partitions**

TW/PRC	TW/PRC	TW/PRC	TW/PRC
<b>Cat. no./Qty.</b>	<b>15546.2/1</b>	<b>15546.2/1</b>	<b>15546.2/1</b>

**PMC labelling/markers**

PMC BSTR 6/30	PMC BSTR 6/30	PMC BSTR 6/30	PMC BSTR 6/30
<b>Cat. no./Qty.</b> , standard print, see catalog	CONTA-CONNECT	CONTA-CONNECT	CONTA-CONNECT
<b>Cat. no./Qty.</b> neutral	<b>9106.7/300</b>	<b>9106.7/300</b>	<b>9106.7/300</b>
<b>Cat. no./Qty.</b> , special print	<b>9107.7/300</b>	<b>9107.7/300</b>	<b>9107.7/300</b>

**BWMA metal tool**

BWMA 1	BWMA 1	BWMA 1	BWMA 1
<b>Cat. no./Qty.</b>	<b>3808.0/1</b>	<b>3808.0/1</b>	<b>3808.0/1</b>

## Solid state relay modules CMS-SSR

- Mounts on TS35
- Compact design, width: 17.5 mm
- Electrical isolation
- Input and output screw connection
- Input AC / DC
- Output AC / DC
- AC/AC - AC/DC - DC/DC - DC/AC operation possible
- Max. output current 24 A per channel
- very small output voltage drop

### CMS-SSR24A



### Circuit diagram

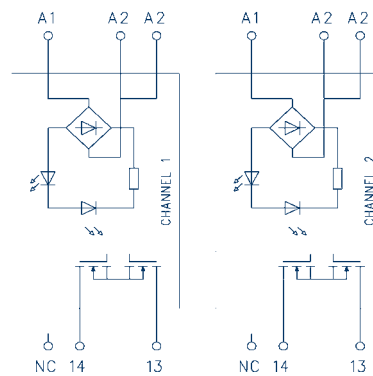

TYPE		CMS-SSR24A	
<b>Cat. no./Qty.</b>		<b>16038.2 / 1</b>	
Size (L x W x H) with TS 35 x 7.5		17.5 x 99 x 114.5 mm	
Weight		106g	
DIN-VDE specifications		DIN EN 50178:1987 ; DIN VDE 0110, contamination degree 2, overvoltage category III	
Electromagnetic properties		EMC Directive 2004/108/EC, in compliance with EN 55011 and EN 61326-1	
Operating temperature		0 to +50°C	
Storage temperature		-25 °C to +70°C	
Connection type		Screw connection	
Connection cross-section		0.2–2.5mm <sup>2</sup>	
Screw connection		AWG 22-14	
Stripping length		12mm	
Mounting position		horizontal	
Mounting interval		0 mm	
		Current on both channels < 32 A Current on both channels > 32 A	
		20 mm	
Input data			
Channels		2	
Rated voltage		24V AC / DC	
Working range DC		9 to 36 V / 10 mA	
Working range AC		10 to 26.4 V / 20 mA	
Output details per channel			
Output		1 Normally open contact	
Max. continuous current		24 A	
Voltage range DC		0 to 50 V	
Voltage range AC		0 to 30 V	
Voltage drop at max. load current		120 mV	
Leakage current 25°C		< 60 µA	
Dielectric strength of control/load circuit		2.5 kV, 50 Hz, 1 min.	
Response time		< 15 ms	
Release time		< 10 ms	
Max. switching frequency		2 Hz	
Indicator		yellow LED	



## Functional Relays

Small control tasks often arise in automation engineering applications. These new functional relays were developed in order to accomplish these tasks as simply as possible. The small size and great flexibility of these relays allows them to be used in many different applications.

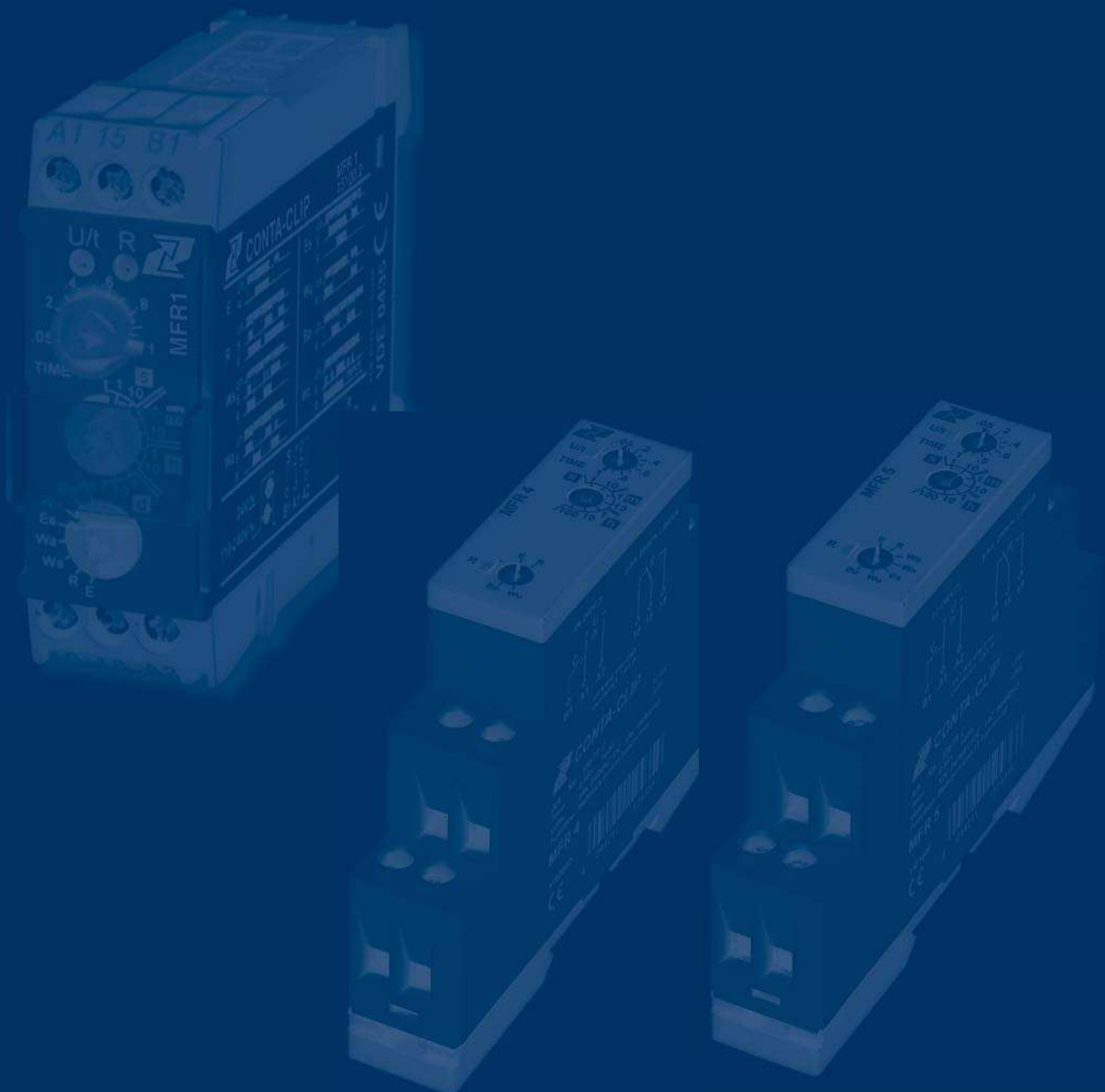

## Functional Relays



### Multi-function timing relay terminal MFR-PRC

The narrow housing of the new MFR-PRC timing relay allows them to be used in very confined spaces. With their minimal width of only 6.2 mm, they open up new possibilities in designing control schemes. Their relay-terminal design makes them very flexible and gives you enormous potential for savings. The bases are compatible with the PRC relay system and can thus be easily integrated.



### MFR 1 | MFR 4 | MFR 5 Multi-function timing relays

Instead of timing units with only one function, these units offer the affordable possibility to implement several common time functions, such as ON-delay, impulse-ON, impulse-OFF, or pulse-monitoring. They reduce storage costs, since only one unit is needed for all applications.



### Clock-pulse generator dual-time relay MFR 6

This functional component is equipped with a definable variable-time flash function. The output relay is controlled in accordance with both set times, until the supply voltage is interrupted. You can select operation - either beginning with pulse or beginning with delay.

## Functional Relays



### **TSR 1 | TSR 2 Staircase lighting time-limit switch**

Electronic step-light time-limit switches with an advance-OFF warning function are functional relays that are often used in building installations. The device can be turned on by pressing the connected push-button. It can be turned off by holding the push-button down. The set time can be increased greatly by repeatedly pressing a push-button.



### **USR 1 | USR 2 Undervoltage-monitor relays**

The undervoltage monitoring of alternating voltage in 3- or 1-phase supply systems can be accomplished with these functional components. They monitor the power supply and protect motors and other power-consuming modules from the effects of phase errors. Voltages that are too low or loss of phase can lead to system failures and as such represent an enormous potential for danger.

## Functional Relays

---



### **SDSR 1 | SDSR 2 Star-delta switching relays**

Star-delta switching is a commonly used function in motor-control engineering. These timing relays were developed in order to accomplish this task as simply as possible. They can be used in different motor types because the transit time is adjustable.



### **VMR 1 | VMR 2 | VMR 3 Voltage monitoring relays**

The voltage-monitoring relays conveniently monitor three-phase systems with and without a neutral wire. By precisely capturing characteristic values, they ensure the accessibility and reliability of a facility or machine. And in doing so, they deliver long-term added value. When operating facilities such as pumps and machines, it is critical to monitor the phase sequence, phase loss and asymmetry. Monitoring allows safe operation and prevents damage in a simple and efficient way.

## Multi-function timing relay terminal MFR-PRC

The narrow housing of the new **MFR-PRC** timing relay allows them to be used in very confined spaces. With their minimal width of only 6.2 mm, they open up new possibilities in designing control schemes. Their relay-terminal design makes them very flexible and gives you enormous potential for savings. The bases are compatible with the **PRC** relay system and can thus be easily integrated. Furthermore, they can be combined with familiar accessories such as jumpers and partitions, and they can be conveniently labelled with the **PMC BSTR** marking system from **CONTA-CLIP**.

**a Labeling | Marking**  
The socket bases have a labeling surface which is optimally suited for our **PMC Pocket-Maxicard (PMC BSTR 6/30)** standard marking systems. In addition to our large variety of standard labels, **CONTA-CLIP** can also provide "just-in-time" individual labeling for you.

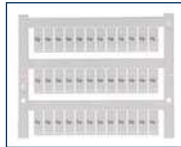

**b Using the mount/dismount lever**  
The mounting and dismounting mechanism forms a reliable connection by latching the relay with the socket base. The fitted relay can be removed, easily and without force, from the socket base by using the dismount function of the lever!

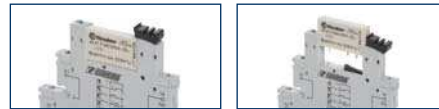

**c Pluggable relays**  
Pluggable relays are also available with AgSNO and gold contacts as well as solid-state modules with a variety of voltage inputs and outputs – to fit with the many functions of your individual requirements!



**d Pluggable external cross-connections**  
The **AQI / PRC** pluggable cross-connection system enables a time-saving distribution of potentials. The **AQI / PRC** is constructed so that it is protected against accidental touch. It is available as a 20-pole unit, in either yellow, blue or black. The cross-connector can be shortened to fewer poles in order to fit the required interface. Insulation plating can be used to insulate the ends.

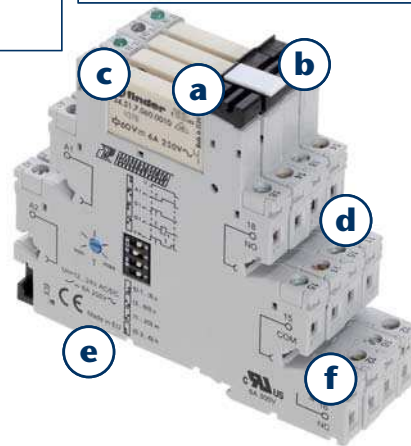

**e Mounts on standard TS 35 rail**  
**CONTA-CLIP** relay terminal can be flexibly mounted on standard TS 35 mounting rails according to EN 50035 and EN 50022.

**f Connection type**  
Screw connection system



### EMC specification

Standard	Test	Voltage
EN 61000-4-2	Electrostatic discharge	Contact discharge Air discharge
EN 61000-4-3	Radio frequency electromagnetic field (80 ÷ 1000 MHz)	10 V/m
EN 61000-4-4	Quick transients (bursts) (5-50 nS, 5 kHz) at input terminals	2 kV
EN 61000-4-5	Surge (1.2/50 µs) at input terminals	Common mode Differential mode
EN 61000-4-6	Radio frequency common mode (0.15 ÷ 80 MHz at input terminals)	10 V
EN 55022	Emissions class	Class B

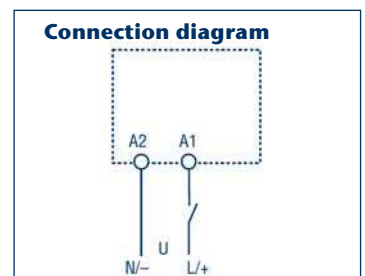
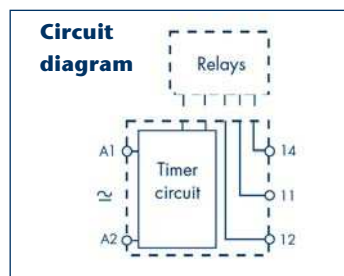
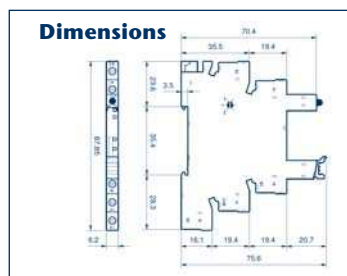

# Multi-function timing relay terminal MFR-PRC

## Time ranges

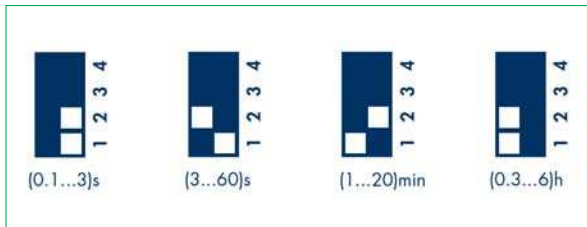

LED	U	Output contact
OFF	OFF	Open
OFF	ON	Open (time running)
ON	ON	Closed

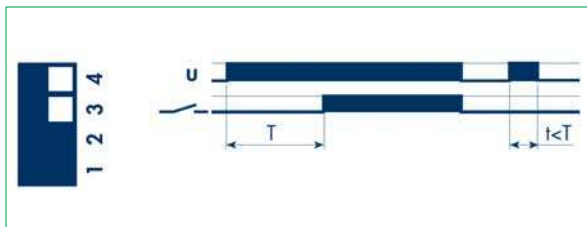

## Functions

### AI: ON delayed

Apply operating voltage to timing relay. The output contacts switch after the set time has expired. Reset takes place after the operating voltage is removed.

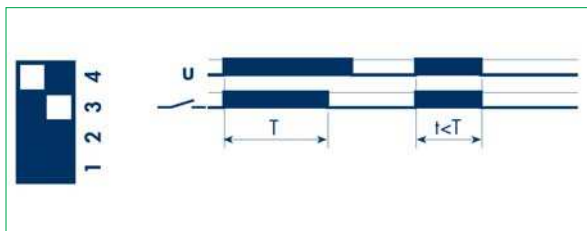

### DI: ON pulse

Apply operating voltage to timing relay. The output contacts switch immediately. After the set time, the output contacts switch back.

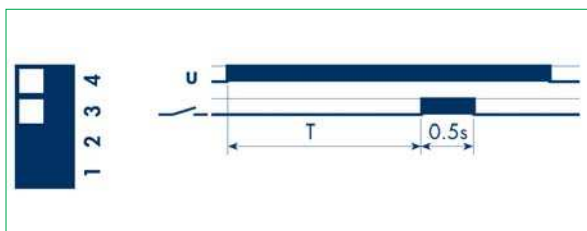

### GI: Fixed pulse (0.5 s) delayed

Apply operating voltage to timing relay. The output contacts switch after the set time has expired. Reset takes place after a fixed time of 0.5 s.

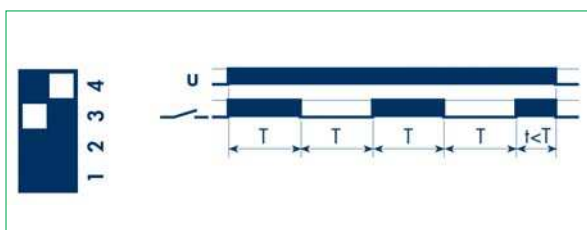

### SW: Flashing ON beginning

Apply operating voltage to timing relay. The output contacts switch on immediately and flash at a defined interval until the input voltage is turned off. The time interval is 1:1 ( time on = time off).

$U$  = supply voltage

= output contact

# Multi-function timing relay terminal MFR-PRC

Screw-connection relay terminals	MFR PRCU 1/12 V AC/DC	MFR PRCU 1/24 V AC/DC
consisting of: <ul style="list-style-type: none"> <li>Basic terminal and pluggable relay</li> <li>Mount on TS 35</li> </ul>		
<b>Type</b>	<b>MFR PRCU 1/12 V AC/DC</b>	<b>MFR PRCU 1/24 V AC/DC</b>
<b>Cat. no./Qty.</b>	<b>15952.2/1</b>	<b>15953.2/1</b>
Size (L x W x H) TS 35	93 x 6.2 x 79.9 mm	93 x 6.2 x 79.9 mm
Weight	36 g	36 g
Operating voltage	12 V AC/DC	24 V AC/DC
<b>Individual parts</b>		
<b>Socket base</b>		
<b>Type</b>	<b>MFR PRC 12-24V AC/DC</b>	<b>MFR PRC 12-24V AC/DC</b>
<b>Cat. no./Qty.</b>	<b>15951.2/10</b>	<b>15951.2/10</b>
Weight	30 g	30 g
Mounting foot for DIN rails	TS 35	TS 35
<b>Functions</b>	AI: ON delayed DI: ON pulse GI: Fixed pulse (0.5s) delayed SW: Flashing (ON beginning)	AI: ON delayed DI: ON pulse GI: Fixed pulse (0.5s) delayed SW: Flashing (ON beginning)
<b>Time delay range</b>	(0.1-3) s, (3-60) s, (1-20) min, (0.3-6) h	(0.1-3) s, (3-60) s, (1-20) min, (0.3-6) h
<b>Displays</b>	LED = Position of output relay	LED = Position of output relay
<b>Connection data</b>		
Connection type	Screw connection	Screw connection
Insulation stripping length	10 mm	10 mm
Tightening torque	0.5 Nm	0.5 Nm
Max. connection cross-section, solid   flexible	1x2.5/2x1.5   1x2.5/2x1.5 mm <sup>2</sup>	1x2.5/2x1.5   1x2.5/2x1.5 mm <sup>2</sup>
Screw connection	1x14/2x16   1x14/2x16 AWG	1x14/2x16   1x14/2x16 AWG
<b>Input data</b>		
Rated operating voltage	12 V AC/DC	24 V AC/DC
Rated output	0.5 W	0.5 W
Operating voltage range	9.6 – 26.4 V AC/DC	9.6 – 26.4 V AC/DC
Power loss		
Without contact current	0.1 W	0.1 W
With rated contact current	0.6 W	0.6 W
<b>Technical data</b>		
Time ranges	(0.1-3) s, (3-60) s, (1-20) min, (0.3-6) h	(0.1-3) s, (3-60) s, (1-20) min, (0.3-6) h
Repeat accuracy	± 1 %	± 1 %
Recovery time	≤ 50 ms	≤ 50 ms
Setting tolerance to end value	± 5 %	± 5 %
Ambient temperature	-40 to +70°C (EMR) / -40 to +55°C (SSR)	-40 to +70°C (EMR) / -40 to +55°C (SSR)
<b>Relay</b>		
<b>Type</b>	<b>PRC 1/12 V DC</b>	<b>PRC 1/24 V DC</b>
<b>Cat. no./Qty.</b>	<b>15501.2/10</b>	<b>15502.2/10</b>
Weight	6 g	6 g
<b>Ratings for plug-relay combined with socket base</b>		
<b>Contacts</b>		
Number of contacts	1 CO contacts	1 CO contacts
Max. continuous current   Max. inrush current	6/10 A	6/10 A
Rated voltage   Max. switching voltage	250/400 V AC*	250/400 V AC*
Max. power rating AC 1	1,500 VA	1,500 VA
Max. power rating AC 15 (230 V AC)	300 VA	300 VA
1-phase motor load, AC 3 operation (230 V AC)	0.185 kW	0.185 kW
Max. switching current DC 1:30/110/220 V	6/0.2/0.12 A	6/0.2/0.12 AA
Min. switching load	300 (5/5) mW (V/mA)	300 (5/5) mW (V/mA)
Standard contact material	AgNi	AgNi
<b>Coil</b>		
Rated voltage (UN)	12 V AC/DC	24 V AC/DC
Power rating AC/DC	0.2 W	0.2 W
<b>Accessories</b> external insulated cross-connector AQI/PRC	<b>AQI/PRC/20</b>	<b>AQI/PRC/8</b>
<b>Cat. no./Qty.</b> , yellow	<b>15545.8/1</b>	<b>15545.8/1</b>
<b>Cat. no./Qty.</b> , blue	<b>15545.5/1</b>	<b>15545.5/1</b>
<b>Cat. no./Qty.</b> , black	<b>15545.4/1</b>	<b>15545.4/1</b>
Partition TW/PRC	<b>TW/PRC</b>	<b>TW/PRC</b>
<b>Cat. no./Qty.</b> per pack	<b>15546.2/1</b>	<b>15546.2/1</b>
Labeling/markers PMC	<b>MC BSTR 6/30</b>	<b>MC BSTR 6/30</b>
<b>Cat. no./Qty.</b> per pack, standard print, see catalog	CONTA-CONNECT	CONTA-CONNECT
<b>Cat. no./Qty.</b> , blank	<b>9106.7/300</b>	<b>9106.7/300</b>
<b>Cat. no./Qty.</b> , special print	<b>9107.7/300</b>	<b>9107.7/300</b>
Tool / screwdriver SDB	<b>SDB 0,6 x 3,5</b>	<b>SDB 0,6 x 3,5</b>
<b>Cat. no./Qty.</b> per pack	<b>1086.0/1</b>	<b>1086.0/1</b>

\*The conditions of pollution degree 2 are fulfilled at 400 V.

# Multi-function timing relay terminal MFR-PSC

Screw-connection solid-state terminals		MFR PSCU 1/24V DC/24V DC	MFR PSCU 1/24V DC/240V DC
consisting of: <ul style="list-style-type: none"> <li>Basic terminal and pluggable solid state module</li> <li>Mount on TS 35</li> </ul>			
<b>Type</b>	<b>MFR PSCU 1/24V DC/24V DC</b>	<b>MFR PSCU 1/24V DC/240V DC</b>	
<b>Cat. no./Qty.</b>	<b>15954.2/1</b>	<b>15955.2/1</b>	
Size (L x W x H) TS 35	93 x 6.2 x 79.9 mm	93 x 6.2 x 79.9 mm	
Weight	36 g	36 g	
Rated operating voltage	24 V AC/DC	24 V AC/DC	
<b>Individual parts</b>			
<b>Socket base</b>			
<b>Type</b>	<b>MFR PRC 12-24 V AC/DC</b>	<b>MFR PRC 12-24 V AC/DC</b>	
<b>Cat. no./Qty.</b>	<b>15951.2/10</b>	<b>15951.2/10</b>	
Weight	30 g	30 g	
Mounting foot for DIN rails	TS 35	TS 35	
<b>Functions</b>			
	AI: ON delayed DI: ON pulse GI: Fixed pulse (0.5 s) delayed SW: Flashing (ON beginning)	AI: ON delayed DI: ON pulse GI: Fixed pulse (0.5 s) delayed SW: Flashing (ON beginning)	
<b>Time delay range</b>			
	(0.1-3) s, (3-60) s, (1-20) min, (0.3-6) h	(0.1-3) s, (3-60) s, (1-20) min, (0.3-6) h	
<b>Displays</b>			
	LED = Position of output relay	LED = Position of output relay	
<b>Connection data</b>			
Connection type	Screw connection	Screw connection	
Insulation stripping length	10 mm	10 mm	
Tightening torque	0.5 Nm	0.5 Nm	
Max. connection cross-section, solid   flexible	1x2.5/2x1.5   1x2.5/2x1.5 mm <sup>2</sup>	1x2.5/2x1.5   1x2.5/2x1.5 mm <sup>2</sup>	
Screw connection	1x14/2x16   1x14/2x16 AWG	1x14/2x16   1x14/2x16 AWG	
<b>Input data</b>			
Rated operating voltage	12 V AC/DC	24 V AC/DC	
Rated output	0.5 W	0.5 W	
Operating voltage range	9.6 – 26.4 V AC/DC	9.6 – 26.4 V AC/DC	
<b>Power loss</b>			
Without contact current	0.1 W	0.1 W	
With rated contact current	0.5 W	0.5 W	
<b>Technical data</b>			
Time ranges	(0.1-3) s, (3-60) s, (1-20) min, (0.3-6) h	(0.1-3) s, (3-60) s, (1-20) min, (0.3-6) h	
Repeat accuracy	± 1 %	± 1 %	
Recovery time	≤ 50 ms	≤ 50 ms	
Setting tolerance to end value	± 5 %	± 5 %	
Ambient temperature	-40 to +70°C (EMR) / -40 to +55°C (SSR)	-40 to +70°C (EMR) / -40 to +55°C (SSR)	
<b>Solid-state module</b>			
<b>Type</b>	<b>PSC 1/24V DC-24 V/2 A/AC</b>	<b>PSC 1/24V/DC-240 V/2 A/AC</b>	
<b>Cat. no./Qty.</b>	<b>15505.2/10</b>	<b>15504.2/10</b>	
Weight	6 g	6 g	
<b>Ratings for solid-state module combined with socket base</b>			
<b>Output circuit</b>			
Output	1 NO	1 NO	
Max. continuous current   Max. inrush current (10 ms)	2/20 A	2/40 A	
Rated voltage   Max. reverse voltage	(24/33) V AC DC	(240/275) V AC	
Switching load-voltage range	1.5 to 24 V DC	12 to 240 V AC	
Min. switching current	1 mA	22 mA	
Max. residual current at 55°C	0.001 mA	1.5 mA	
Max. voltage drop at 20°C and rated current	0.12 V	1.6 V	
<b>Accessories</b>			
external insulated cross-connector AQI/PRC	<b>AQI/PRC/20</b>	<b>AQI/PRC/20</b>	
<b>Cat. no./Qty.</b> , yellow	<b>15545.8/1</b>	<b>15545.8/1</b>	
<b>Cat. no./Qty.</b> , blue	<b>15545.5/1</b>	<b>15545.5/1</b>	
<b>Cat. no./Qty.</b> , black	<b>15545.4/1</b>	<b>15545.4/1</b>	
Partition TW/PRC	<b>TW/PRC</b>	<b>TW/PRC</b>	
<b>Cat. no./Qty.</b> per pack	<b>15546.2/1</b>	<b>15546.2/1</b>	
Labeling/markers PMC	<b>MC BSTR 6/30</b>	<b>MC BSTR 6/30</b>	
<b>Cat. no./Qty.</b> per pack, standard print, see catalog	CONTA-CONNECT	CONTA-CONNECT	
<b>Cat. no./Qty.</b> , blank	<b>9106.7/300</b>	<b>9106.7/300</b>	
<b>Cat. no./Qty.</b> , special print	<b>9107.7/300</b>	<b>9107.7/300</b>	
Tool / screwdriver SDB	<b>SDB 0,6 x 3,5</b>	<b>SDB 0,6 x 3,5</b>	
<b>Cat. no./Qty.</b> per pack	<b>1086.0/1</b>	<b>1086.0/1</b>	

# Multi-functional timing relays MFR

MFR 1 | MFR 4 | MFR 5

## Specifications

### Mechanical design

- Mount on TS 35
- Housing made of self-extinguishing plastic, IP40 protection
- Any mounting position possible
- Screw connections protected against accidental touch, according to VBG 4, IP20 protection

### Screw connection

- 1 x 0.5 to 2.5 mm<sup>2</sup> with/without wire-end ferrules
- 1 x 4 mm<sup>2</sup> without wire-end ferrules
- 2 x 0.5 to 1.5 mm<sup>2</sup> with/without wire-end ferrules
- 2 x 2.5 mm<sup>2</sup> flexible without wire-end ferrules
- Tightening torque max. 1 Nm

### Description of function

- The module must be disconnected from the power supply before selection of the timing function
- Please refer to data sheet or information printed on the module for a complete list of the various module functions

#### ON delay (E)

The set time  $t$  begins to run with the application of the supply voltage  $U$ . The green LED  $U/t$  flashes. After the time  $t$  has passed (the green LED  $U/t$  is lit), the output relay  $R$  goes on (yellow LED lit). This status is maintained until the supply voltage is interrupted. If the supply voltage is interrupted before the expiration of the time  $t$ , then the expired time is deleted and the time starts anew when the supply voltage is re-applied.

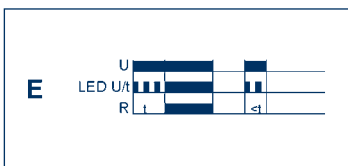

#### Impulse-ON with control contact (Ws)

The supply voltage  $U$  must constantly be applied to device (green LED  $U/t$  is lit). The output relay  $R$  activates (yellow LED lit) when the control contact  $S$  closes, and the set time  $t$  begins (green LED  $U/t$  flashes). After the time  $t$  has passed (green LED  $U/t$  is lit), the output relay deactivates (yellow LED not lit up). The control contact can be switched while the time is running. A further cycle can be started only when the currently running cycle is closed.

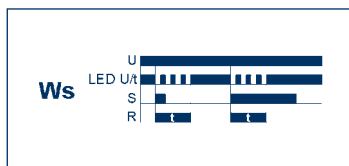

#### ON-delay with control contact (Es)

The supply voltage  $U$  must constantly be applied to device (green LED  $U/t$  is lit). The set time  $t$  begins when the control contact  $S$  is closed. The green LED  $U/t$  flashes. The output relay  $R$  activates (yellow LED is lit) after the expiration of the time  $t$  (green LED  $U/t$  is lit). This status is maintained until the control contact is opened. If the control contact is opened before the expiration of the time  $t$ , then the expired time is deleted and the time starts anew with the next cycle.

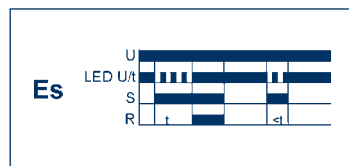

#### Flasher begin with delay (Bp)

The set time  $t$  begins to run with the application of the supply voltage  $U$ . The green LED  $U/t$  flashes. After the time  $t$  has passed, the output relay  $R$  goes on (the yellow LED lights up), and the set time  $t$  begins again. After the time  $t$  has passed, the output relay deactivates (yellow LED not lit). The output relay is controlled in a 1:1 ratio until the supply voltage is interrupted.

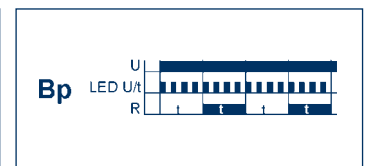

#### OFF-delay with control contact (R)

The supply voltage  $U$  must constantly be applied to device (green LED  $U/t$  is lit). The output relay  $R$  activates (yellow LED lit) when the control contact  $S$  closes. The set time  $t$  begins to run when the control contact  $S$  is opened. The green LED  $U/t$  flashes. The output relay  $R$  deactivates (yellow LED not lit) after the expiration of the time  $t$  (green LED  $U/t$  is lit). If the control contact is closed again before time  $t$  is expired, then the expired time is deleted and the time starts anew with the next cycle.

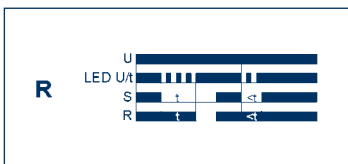

#### Impulse-OFF with control contact (Wa)

The supply voltage  $U$  must constantly be applied to device (green LED  $U/t$  is lit). The closure of control contact  $S$  has no influence on the positioning of the output relay  $R$ . When the control contact opens, the output relay activates (yellow LED is lit) and the set time  $t$  begins to run (green LED  $U/t$  flashes). The output relay  $R$  deactivates (yellow LED not lit) after the expiration of the time  $t$  (green LED  $U/t$  is lit). The control contact can be switched while the time is running. A further cycle can be started only when the currently running cycle is closed.

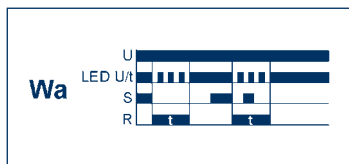

#### Impulse-ON voltage controlled (Wu)

The output relay  $R$  is activated (yellow LED lit) when the supply voltage is applied. The set time then begins to run (green LED  $U/t$  flashes). The output relay deactivates (yellow LED not lit) after the expiration of the time  $t$  (green LED  $U/t$  is lit). This status is maintained until the supply voltage is interrupted. If the supply voltage is interrupted before the time  $t$  expires, the the output relay is deactivated. The time that has already expired is deleted and when the supply voltage is re-applied the time is started anew.

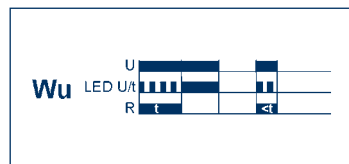

#### Pulse monitoring (Wt)

The output relay  $R$  activates (yellow LED is lit) after the supply voltage is applied (green LED  $U/t$  is lit). The set time  $t$  begins when the control contact  $S$  is closed. The green LED  $U/t$  flashes. In order to keep the output relay activated, the control contact must be opened and then closed during the set time  $t$ . If this does not occur, the output relay is deactivated, and all further pulses to the control contact are ignored. In order to re-start this function, the supply voltage must be interrupted and re-applied.

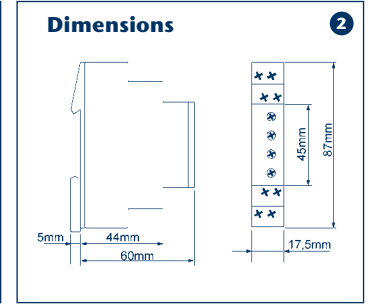
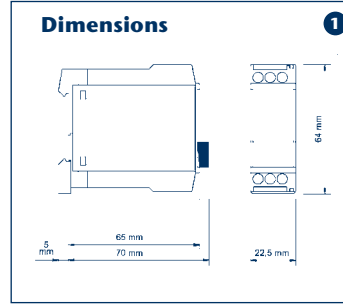
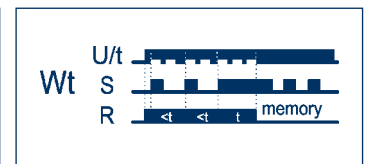

### Environmental conditions

Ambient temperature	-25 to +55°C (acc. to IEC 68-1) -25 to +40°C (UL 508)
Storage temperature	-25 to +70°C
Transport temperature	-25 to +70°C
Relative humidity	15% to 85% (acc. to IEC 721-3-3 Class 3K3)
Pollution degree	3 (acc. to IEC 664-1)
Vibration resistance	10 to 55 Hz 0.35 mm (acc. to IEC 68-2-6)
Shock resistance	15 g 11 ms (acc. to IEC 68-2-27)

	MFR 1	MFR 4	MFR 51
<b>Type</b>	<b>MFR 1</b>	<b>MFR 4</b>	<b>MFR 51</b>
<b>Cat. no./Qty.</b>	<b>15100.2/1</b>	<b>15677.2/1</b>	<b>15678.2/1</b>
Dimensions	1	2	2
Wiring diagram	1	2, 3	2, 3
Dimensions (L x W x H) TS 35 x 7.5	64 x 22.5 x 77.5 mm	87 x 17.5 x 67.5 mm	87 x 17.5 x 67.5 mm
Weight (individual packaging: module and packaging)	65 g	65 g	65 g
<b>Short description</b>	<b>Timing relay</b>	<b>Timing relay</b>	<b>Timing relay</b>
	Multi-functional	Multi-functional	Multi-functional
	8 functions	4 functions	7 functions
	8 time delay ranges	7 time delay ranges	7 time delay ranges
	1 CO contact	Wide-range input	Wide-range input
	Width 22.5 mm	1 CO contact	1 CO contact
	Industrial construction	Width 17.5 mm	Width 17.5 mm
<b>Functions</b>		Installation design	Installation design
<b>Time ranges / setting ranges</b>	E, R, Ws, Wa, Es, Wu, Bp, Wt*	E, R, Wu, Bp*	E, R, Ws, Wa, Es, Wu, Bp*
<b>Displays</b>	50 ms to 10 d	50 ms to 100 h	50 ms to 100 h
<b>Input circuit</b>	Green LED U/t ON* Green LED U/t flashes* Yellow LED R ON/OFF*	Green LED U/t ON* Green LED U/t flashes* Yellow LED R ON/OFF*	Green LED U/t ON* Green LED U/t flashes* Yellow LED R ON/OFF*
Supply voltage	24 V DC, terminals A1(+)-A2(-), switch engaged 24 V DC, terminals A1-A2, switch disengaged 110 to 240 V AC, terminals A1-A2, switch dis-engaged	24 to 240 V AC/DC, terminals A1(+)-A2(-)	12 to 240 V AC/DC terminals A1(+)-A2(-)
Tolerance	24 V DC ± 10 % 24 V AC -15% to +10% 110 to 240 VAC -15% to +10%	24 V -15 % to 240 V +10%	12 V -10% to 240 V +10%
Rated frequency	48 to 63 Hz	48 to 63 Hz	48 to 63 Hz
Rated consumption	24 V AC/DC 1.5 VA (1 W) 110 V AC 2 VA (1 W) 240 V AC 8 VA (1.3 W)	4 VA (1.5 W)	4 VA (1.5 W)
ON duration	100 %	100 %	100 %
Recovery time	250 ms	100 ms	100 ms
Residual ripple with DC	10 %	10 %	10 %
Release voltage	> 30% of the min. Supply voltage	> 30% of the min. Supply voltage	> 30% of the min. Supply voltage
Overvoltage category	III (acc. to IEC 664-1)	III (acc. to IEC 664-1)	III (acc. to IEC 664-1)
Rated impulse voltage	4 kV	4 kV	4 kV
<b>Output circuit</b>	<b>1 potential-free CO contact</b>	<b>1 potential-free CO contact</b>	<b>1 potential-free CO contact</b>
Rated voltage	250 V AC	250 V AC	250 V AC
Switching capacity of module mounted side-by-side (gap < 5 mm)	1250 VA (5 A/250 V AC)	2000 VA (8 A/250 V AC)	2000 VA (8 A/250 V AC)
Switching capacity of module not mounted side-by-side (gap < 5 mm)	2000 VA (8 A/250 V AC)	2000 VA (8 A/250 V AC)	2000 VA (8 A/250 V AC)
Fusing	8 A fast	8 A fast	8 A fast
Mechanical life span	20 x 10 <sup>5</sup> switching cycles	20 x 10 <sup>5</sup> switching cycles	20 x 10 <sup>5</sup> switching cycles
Electrical service life	2 x 10 <sup>5</sup> switching cycles at 1000 VA* Max. 60/min at 100 VA* Max. 6/min at 1000 VA* (acc. to IEC 947-5-1)	2 x 10 <sup>5</sup> switching cycles at 1000 VA* Max. 60/min at 100 VA* Max. 6/min at 1000 VA* (acc. to IEC 947-5-1)	2 x 10 <sup>5</sup> switching cycles at 1000 VA* Max. 60/min at 100 VA* Max. 6/min at 1000 VA* (acc. to IEC 947-5-1)
Switching frequency	250 VAC (acc. to IEC 664-1)	250 VAC (acc. to IEC 664-1)	250 VAC (acc. to IEC 664-1)
Rated insulation voltage	250 VAC (acc. to IEC 664-1)	250 VAC (acc. to IEC 664-1)	250 VAC (acc. to IEC 664-1)
Overvoltage category	III (acc. to IEC 664-1)	III (acc. to IEC 664-1)	III (acc. to IEC 664-1)
Rated impulse voltage	4 kV	4 kV	4 kV
Process times (without relay switching times)			
ON delay	AC 25-55 ms, DC 35-45 ms		
OFF delay	AC/DC 10-20 ms		
Stored energy time when voltage fails	Max. 10 ms		
<b>Control contact</b>			
Input	Non-floating, terminals A1-B1	Non-floating, terminals A1-B1	Non-floating, terminals A1-B1
Load capacity	Parallel load, min. 1 VA (0.5 W) Terminals A2-B1	Yes	Yes
Response threshold		Automatically adjusted to supply voltage	Automatically adjusted to supply voltage
Maximum cable length	10 m	10 m	10 m
Minimum pulse duration	AC/DC 50 ms	DC 50 ms/AC 100 ms	DC 50 ms/AC 100 ms
<b>Accuracy</b>			
Basic accuracy	± 1% (from scale reading)	± 1% (from scale reading)	± 1% (from scale reading)
Setting tolerance	≤ 5% (from scale reading)	≤ 5% (from scale reading)	≤ 5% (from scale reading)
Repeat accuracy	< 0.5% or ± 5 ms	< 0.5% or ± 5 ms	< 0.5% or ± 5 ms
Voltage influence	-	-	-
Temperature influence	≤ 0.01% /°C	≤ 0.01% /°C	≤ 0.01% /°C

**Connection diagram**

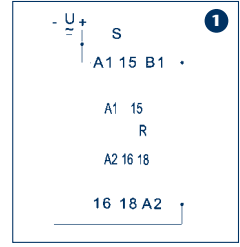

**With control contact**

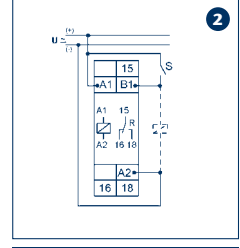

**Without control contact**

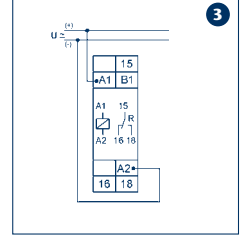

**Legend:**  
**E** ON-delay  
**R** OFF-delay\*  
**Ws** Impulse-ON\*  
**Wa** Impulse-OFF\*  
**Es** ON-delay\*  
**Wu** Impulse-ON Voltage controlled  
**Bp** Flasher begin with delay  
**Wt** Pulse monitoring  
 \*with control contact  
**Green LED U/t ON:** Supply voltage applied  
**Green LED U/t flashing:** Indicates timing period  
**Yellow LED R ON/OFF:** Position of output relay  
**Output circuit**  
 VA resistive load

\* see legend

# Clock-pulse generator dual-timing relays MFR

## MFR 6

### Specifications

#### Mechanical design

- Mount on TS 35
- Housing made of self-extinguishing plastic, IP40 protection
- Any mounting position possible
- Screw connections protected against accidental touch, according to VBG 4, IP20 protection

#### Screw connection

- 1 x 0.5 to 2.5 mm<sup>2</sup> with/without wire-end ferrules
- 1 x 4 mm<sup>2</sup> without wire-end ferrules
- 2 x 0.5 to 1.5 mm<sup>2</sup> with/without wire-end ferrules
- 2 x 2.5 mm<sup>2</sup> flexible without wire-end ferrules
- Tightening torque max. 1 Nm

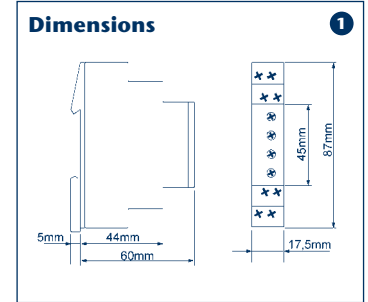

#### Environmental conditions

Ambient temperature	-25 to +55°C (acc. to IEC 68-1) -25 to +40°C (UL 508)
Storage temperature	-25 to +70°C
Transport temperature	-25 to +70°C
Relative humidity	15% to 85% (acc. to IEC 721-3-3 Class 3K3)
Pollution degree	3 (acc. to IEC 664-1)
Vibration resistance	10 to 55 Hz 0.35 mm (acc. to IEC 68-2-6)
Shock resistance	15 g 11 ms (acc. to IEC 68-2-27)

### Description of function

#### Pulsed begin with delay (Ip)

The set time t1 begins to run with the application of the supply voltage U. (The green LED U/t flashes slowly.) After the time t1 expires, the output relay R activates (yellow LED is lit), and the time t2 begins to run (green LED U/t flashes quickly). After the time t2 has expired, the output relay deactivates (yellow LED not lit). The output relay is controlled in accordance with both set times- until the supply voltage is interrupted.

#### Pulsed begin with pulse (Ii)

The output relay R is activated (yellow LED lit) when the supply voltage U is applied. The set time t1 then begins to run (green LED U/t flashes slowly). After the time t1 has expired, the output relay is deactivated (yellow LED not lit), and the set time t2 begins to run (green LED flashes quickly). After the time t2 has expired, the output relay re-activates (yellow LED is lit). The output relay is controlled in accordance with both set times- until the supply voltage is interrupted.

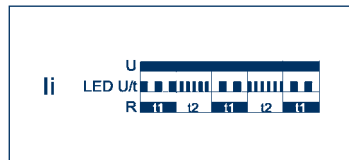
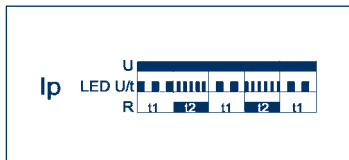

	MFR 6		
			
<b>Type</b>	<b>MFR 6</b>		
<b>Cat. no./Qty.</b>	<b>15679.2/1</b>		
Dimensions	1		
Wiring diagram	1		
Dimensions (L x W x H) TS 35 x 7.5	87 x 17.5 x 67.5 mm		
Weight (individual packaging: module and packaging)	72 g		
<b>Short description</b>	<b>Clock pulse generator</b>		
	7 time delay ranges		
	Wide-range input		
	1 CO contact		
	Width 17.5 mm		
	Installation design		
<b>Functions</b>			
	Ip Pulsed begin with delay		
	Ii Pulsed begin with pulse (with jumper A1-B1)		
<b>Time ranges / setting ranges</b>			
	50 ms to 100 h		
<b>Display</b>			
	Green LED U/t ON*		
	Green LED V/t flashes slowly*		
	Green LED V/t flashes quickly*		
	Yellow LED R ON/OFF*		
<b>Input circuit</b>			
Supply voltage	12 to 240 V AC/DC, terminals A1(+)-A2(-)		
Tolerance	12 V -10% to 240 V +10%		
Rated frequency	48 to 63 Hz		
Rated consumption	4 VA (1.5 W)		
ON duration	100 %		
Recovery time	100 ms		
Residual ripple with DC	10 %		
Release voltage	> 30 % of the min. supply voltage		
Overvoltage category	III (acc. to IEC 664-1)		
Rated impulse voltage	4 kV		
<b>Output circuit</b>			
Rated voltage	1 potential-free CO contact 250 V AC		
Switching capacity of module mounted side-by-side (gap < 5 mm)	2000 VA (8 A/250 V AC)		
Switching capacity of module not mounted side-by-side (gap < 5 mm)	2000 VA (8 A/250 V AC)		
Fusing	8 A fast		
Mechanical life span	20 x 10 <sup>6</sup> switching cycles		
Electrical service life	2 x 10 <sup>5</sup> switching cycles at 1000 VA*		
Switching frequency	Max. 60/min at 100 VA* Max. 6/min at 1000 VA* (acc. to IEC 947-5-1)		
Overvoltage category	III (acc. to IEC 664-1)		
Rated impulse voltage	4 kV		
<b>Control contact</b>			
Input	Non-floating, terminals A1-B1		
Load capacity	Yes		
Response threshold	Automatically adjusted to supply voltage		
Maximum cable length	10 m		
<b>Accuracy</b>			
Basic accuracy	± 1% (from scale reading)		
Setting tolerance	< 5 % (from scale reading)		
Repeat accuracy	< 0.5% or ± 5 ms		
Voltage influence	-		
Temperature influence	≤ 0.01% /°C		

### Connection diagram

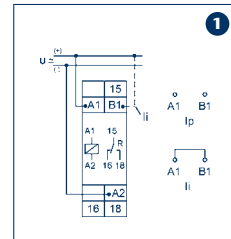

### Legend:

- Green LED U/t ON:** Supply voltage applied
- Green LED U/t flashes slowly:** Indicates timing period t1
- Green LED U/t flashes quickly:** Indicates timing period t2
- Yellow LED R ON/OFF:** Position of output relay

**Output circuit**  
VA resistive load

\* see legend

# Staircase lighting time-limit switch TSR

TSR 1 | TSR 2

## Specifications

### Mechanical design

- Mount on TS 35
- Housing made of self-extinguishing plastic, IP40 protection
- Any mounting position possible
- Screw connections protected against accidental touch, according to VBG 4, IP20 protection

### Screw connection

- 1 x 0.5 to 2.5 mm<sup>2</sup> with/without wire-end ferrules
- 1 x 4 mm<sup>2</sup> without wire-end ferrules
- 2 x 0.5 to 1.5 mm<sup>2</sup> with/without wire-end ferrules
- 2 x 2.5 mm<sup>2</sup> flexible without wire-end ferrules
- Tightening torque max. 1 Nm

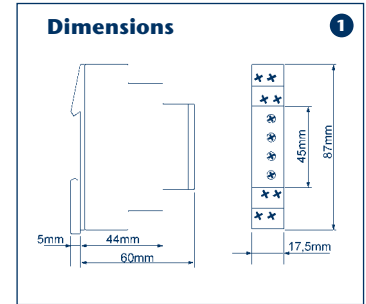

### Environmental conditions

Ambient temperature	-25 to +55°C (acc. to IEC 68-1) -25 to +40°C (UL 508)
Storage temperature	-25 to +70°C
Transport temperature	-25 to +70°C
Relative humidity	15% to 85% (acc. to IEC 721-3-3 Class 3K3)
Pollution degree	3 (acc. to IEC 664-1)
Vibration resistance	10 to 55 Hz 0.35 mm (acc. to IEC 68-2-6)
Shock resistance	15 g 11 ms (acc. to IEC 68-2-27)

## Description of function

Electronic staircase lighting time-limit switches with an advance-OFF warning function. The control input allows for a connection of push-buttons with up to a total of 100 mA glow-lamp current. It can be used in three- or four-cable circuits. The device can be re-triggered by pressing the connected push-buttons or turned off by pressing down for a longer time on the push-button (energy-saving function). Rapid multiple pressing (“pumping”) of the button extends the interval by the set time t. Depending on the design version, the following operating modes can be selected with the front control unit:

### The automatic timing function (T, TW)

After pressing the button B1, the output relay R closes (terminals L-18) and the set time t begins to run. If the button is pressed again before the time t expires, then the time begins anew (the re-start function complies with EN 60669-2-3). Quick multiple pressing of the button (pumping) adds two, three, or more intervals to extend the time up to 60 minutes. Prolonged pressing of the button (more than two seconds) then aborts the running interval, and the relay turns off (energy saving function). The TW mode the device provides a switch-off warning (complies with DIN 180-15-2) by generating short pulses (flashes) at 30, 15, and 5 seconds before switch-off.



### Operational possibilities with B1 in automatic timing

The additional control inputs C1-C2 is used in the T and TW modes to control the staircase lighting timer using a voltage from 8 - 230 V AC/DC. This input can be used to start and restart the time cycle. It can not be used for switch-off (energy saving) or for programming longer intervals (pumping).

### Impulse switch mode (P), (PN)

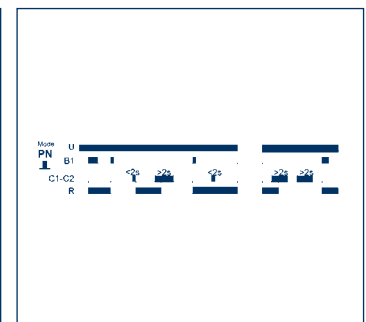
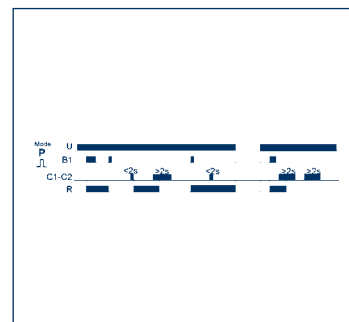
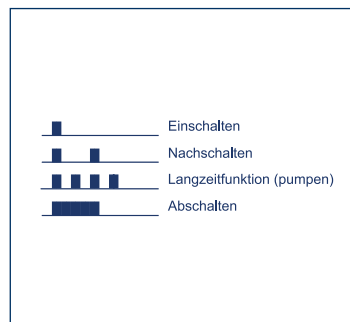
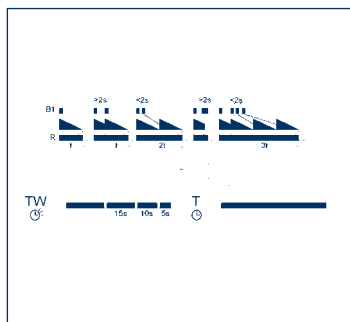
In impulse switch mode, every button press (on B1) switches (toggles) the output relay T. In the P function, the output relay R remains in the off-position when the supply voltage is applied. In the PN function, the output relay R switches to on-position immediately after the supply voltage is applied, if the relay was on before the last power stoppage. The output relay R switches to on-position (central ON), if a short (< 2 sec.) voltage impulse is applied to the additional control input C1-C2. A longer voltage impulse (> 2 sec.) turns off the output relay R (central OFF).



	TSR 1	TSR 2	
			
<b>Type</b>	<b>TSR 1</b>	<b>TSR 2</b>	
<b>Cat. no./Qty.</b>	<b>15680.2/1</b>	<b>15681.2/1</b>	
Dimensions	1	1	
Wiring diagrams	1, 2	1, 2	
Dimensions (L x W x H) TS 35 x 7.5	87 x 17.5 x 67.5 mm	87 x 17.5 x 67.5 mm	
Weight (individual packaging: module and packaging)	106 g	106 g	
<b>Short description</b>	<b>Staircase light timer, electronic</b>	<b>Staircase light timer, electronic</b>	
	Advance turn-off warning	Advance turn-off warning	
	Retrigger function, extended time function	Retrigger function, extended time function	
	Energy saving	Energy saving	
	Selectable impulse relay mode	Selectable impulse relay mode	
	Low switching noise	Low switching noise	
	High switching capacity	High switching capacity,	
	80 A inrush current peak	80 A inrush current peak	
	Automatic 3 or 4 cable recognition	Automatic 3 or 4 cable recognition	
	Glow lamp load up to 100 mA	Glow lamp load up to 100 mA	
	Width 17.5 mm	Width 17.5 mm	
	Installation design	Installation design	
<b>Functions</b>			
	Tw, P, 1, 0	TW, T, 1, 0, P, PN	
<b>Time ranges / setting ranges</b>			
	Time delay	Time delay	
	0.5 to 12 min (in function T, TW)	0.5 to 12 min (in function T, TW)	
<b>Display</b>			
	Green LED U/t ON*	Green LED U/t ON*	
	Yellow LED R ON/OFF*	Yellow LED R ON/OFF*	
<b>Input circuit</b>			
Supply voltage	Terminals L - N	Terminals L - N	
Rated voltage	230 V AC	230 V AC	
Tolerance	-15 % to +10 %	-15 % to +10 %	
Rated frequency	48 to 63 Hz	48 to 63 Hz	
Rated consumption	2 VA (1.0 W)	2 VA (1.0 W)	
ON duration	100 %	100 %	
Recovery time	500 ms	500 ms	
Stored energy time	-	-	
Residual ripple with DC	-	-	
Release voltage	> 30 %	> 30 %	
Overvoltage category	III (acc. to IEC 664-1)	III (acc. to IEC 664-1)	
Rated impulse voltage	4 kV	4 kV	
<b>Output circuit</b>			
Rated voltage	1 NO contact, terminals L - 18	1 NO contact, terminals L - 18	
	250 V AC	250 V AC	
Switching capacity of module mounted side-by-side (gap < 5 mm)	10 A continuous current	10 A continuous current	
Switching capacity of module not mounted side-by-side (gap < 5 mm)	16 A continuous current	16 A continuous current	
Inrush current peak (20 ms)	80 A	80 A	
Mechanical life span	30 x 10 <sup>6</sup> switching cycles	30 x 10 <sup>6</sup> switching cycles	
Electrical service life			
Resistive load	2 x 10 <sup>5</sup> switch. cycles at 16 A/250 V	2 x 10 <sup>5</sup> switch. cycles at 16 A/250 V	
Glow lamp load	80,000 switch. cycles at 1000 W/250 V	80,000 switch. cycles at 1000 W/250 V	
Overvoltage category	III (acc. to IEC 664-1)	III (acc. to IEC 664-1)	
Rated impulse voltage	4 kV	4 kV	
<b>Control contact</b>			
Connection	Control input B1	Control input B1	
	Non-floating, push-button B1-N (3-cable circuit), push-button B1-L (4-cable circuit)	Non-floating, push-button B1-N (3-cable circuit), push-button B1-L (4-cable circuit)	
Glow lamp load	Max. 100 mA parallel to the push-buttons	Max. 100 mA parallel to the push-buttons	
Overload protection	Yes, electronic	Yes, electronic	
<b>Additional control input</b>			
Connection	-	Control voltage on terminals C1(+)-C2	
Control voltage	-	8 to 230 V AC/DC	
Electrical isolation	-	Yes, basic insulation	
Overvoltage category	-	III (acc. to IEC 60664-1)	
Rated impulse voltage	-	4 kV	
<b>Accuracy</b>			
Basic accuracy	± 5 % (from scale reading)	± 5 % (from scale reading)	
Setting tolerance	< 15 % (from scale reading)	< 15 % (from scale reading)	
Repeat accuracy	< 2 %	< 2 %	
Voltage influence	-	-	
Temperature influence	≤ 1 %	≤ 1 %	

#### Connection diagram

#### 3-cable circuit

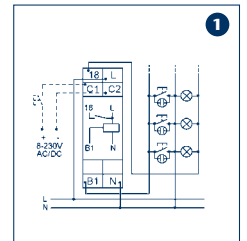

#### 4-cable circuit with attic illumination

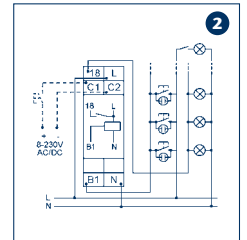

#### Legend:

- TW:** Automatic timing function with advance turn-off warning
- T:** Automatic timing function without advance turn-off warning
- 1:** Continuous lighting
- 0:** Switched off
- P:** Impulse relay without timing function
- PN:** Impulse relay
- Neutral-voltage safe**
- Green LED U/t ON:** Supply voltage applied
- Yellow LED R ON/OFF:** Position of output relay

\* see legend

# Undervoltage monitoring relays USR

USR 1 | USR 2

## Specifications

### Mechanical design

- Mount on TS 35
- Housing made of self-extinguishing plastic, IP40 protection
- Any mounting position possible
- Screw connections protected against accidental touch, according to VBG 4, IP20 protection

### Screw connection

- 1 x 0.5 to 2.5 mm<sup>2</sup> with/without wire-end ferrules
- 1 x 4 mm<sup>2</sup> without wire-end ferrules
- 2 x 0.5 to 1.5 mm<sup>2</sup> with/without wire-end ferrules
- 2 x 2.5 mm<sup>2</sup> flexible without wire-end ferrules
- Tightening torque max. 1 Nm

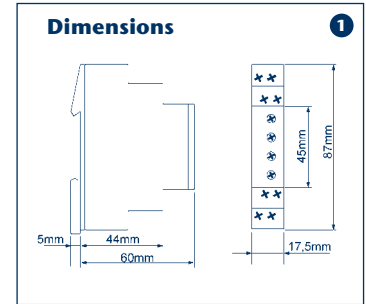

### Environmental conditions

Ambient temperature	-25 to +55°C (acc. to IEC 68-1) -25 to +40°C (UL 508)
Storage temperature	-25 to +70°C
Transport temperature	-25 to +70°C
Relative humidity	15% to 85% (acc. to IEC 721-3-3 Class 3K3)
Pollution degree	3 (acc. to IEC 664-1)
Vibration resistance	10 to 55 Hz 0.35 mm (acc. to IEC 68-2-6)
Shock resistance	15 g 11 ms (acc. to IEC 68-2-27)

### Description of function

Undervoltage monitoring for three-phase AC mains with a fixed (UFR 1) or variable (UFR 2) switching threshold, and a fixed hysteresis. All measuring inputs (L1, L2, and L3) must each be connected to a phase voltage. If three-phase measurements are not desired, then multiple measurement inputs should be connected to one phase, so that all inputs have the appropriate voltage applied. If the reverse voltage coming from the load exceeds the threshold  $U_s$ , then a phase failure can not be detected.

### Undervoltage monitoring without the optional time function

The output relay activates (yellow LED lit) when the measured voltage of all connected phases exceeds the threshold  $U_s$  by more than the hysteresis. When the voltage of one of the connected phases falls below the fixed threshold value, the output relay is deactivated (yellow LED not lit).

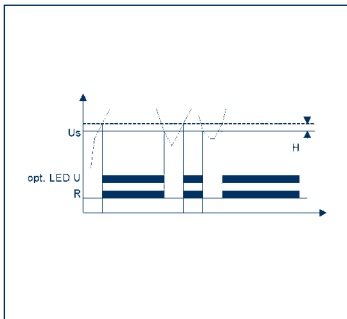

	USR 1	USR 2	
			
<b>Type</b>	<b>USR 1</b>	<b>USR 2</b>	
<b>Cat. no./Qty.</b>	<b>15682.2/1</b>	<b>15683.2/1</b>	
Dimensions	1	1	
Wiring diagrams	1, 2	1, 2	
Dimensions (L x W x H) TS 35 x 7.5	87 x 17.5 x 67.5 mm	87 x 17.5 x 67.5 mm	
Weight (individual packaging: module and packaging)	72 g	72 g	
<b>Short description</b>	<b>Undervoltage Monitoring relay</b>	<b>Undervoltage Monitoring relay</b>	
	Voltage monitoring 3-phase	Voltage monitoring 3-phase	
	Undervoltage monitoring of supply voltage = measured voltage	Undervoltage monitoring of supply voltage = measured voltage	
	Switching threshold fixed for systems acc. to VDE0108	Switching threshold, variable	
	1 CO contact Width 17.5 mm	1 CO contact Width 17.5 mm	
	Installation design	Installation design	
<b>Time ranges / setting ranges</b>	<b>Output delay</b>	<b>Output delay</b>	
	Quick, approx. 200 ms	Quick, approx. 200 ms	
<b>Display</b>	Yellow LED R ON/OFF*	Yellow LED R ON/OFF* Green LED L1 ON/OFF* Green LED L2 ON/OFF* Green LED L3 ON/OFF*	
<b>Input circuit</b>			
Supply voltage	= measured voltage	= measured voltage	
Terminals	N-L1-L2-L3	N-L1-L2-L3	
Rated voltage	Un: 3N-400/230 V	Un: 3N-400/230 V	
Tolerance	-30 % to +10 % from Un	-30 % to +10 % from Un	
Rated frequency	48 to 63 Hz	48 to 63 Hz	
Rated consumption	5 VA (0.6 W)	8 VA (0.8 W)	
ON duration	100 %	100 %	
Recovery time	500 ms	500 ms	
Stored energy time	-	-	
Release voltage	Defined by measurement function	Defined by measurement function	
Overvoltage category	III (acc. to IEC 664-1)	III (acc. to IEC 664-1)	
Rated impulse voltage	4 kV	4 kV	
<b>Output circuit</b>	<b>1 potential-free CO contact</b>	<b>1 potential-free CO contact</b>	
Switching capacity	250 V AC	250 V AC	
Switching capacity of module mounted side-by-side (gap < 5 mm)	1250 VA (5 A/250 V AC)	1250 VA (5 A/250 V AC)	
Switching capacity of module not mounted side-by-side (gap < 5 mm)	1250 VA (5 A/250V AC)	1250 VA (5 A/250 V AC)	
Fusing	5 A fast	5 A fast	
Mechanical life span	20 x 10 <sup>5</sup> switching cycles	20 x 10 <sup>5</sup> switching cycles	
Electrical service life	2 x 10 <sup>5</sup> switching cycles at 1000 VA*	2 x 10 <sup>5</sup> switching cycles at 1000 VA*	
Switching frequency	Max. 60/min at 100 VA* Max. 6/min at 1000 VA* (acc. to IEC 947-5-1)	Max. 60/min at 100 VA* Max. 6/min at 1000 VA* (acc. to IEC 947-5-1)	
Overvoltage category	III (acc. to IEC 664-1)	III (acc. to IEC 664-1)	
Rated impulse voltage	4 kV	4 kV	
<b>Measurement circuit</b>			
Measured quantity	AC sinusoidal, 48 to 68 Hz	AC sinusoidal, 48 to 68 Hz	
Measurement input	= supply voltage	= supply voltage	
Terminals	N-L1-L2-L3	N-L1-L2-L3	
Overload capability	Defined by the tolerance of the supply voltage	Defined by the tolerance of the supply voltage	
Input resistance	-	-	
Switching threshold Us	Fast 195.5 V (L-N) for installations to VDE 0108	160 to 240 V (L-N)	
Hysteresis H	Approx. 5 %	Approx. 5 %	
Overvoltage category	III (acc. to IEC 664-1)	III (acc. to IEC 664-1)	
Rated impulse voltage	4 kV	4 kV	
<b>Accuracy</b>			
Basic accuracy	± 5 % of rated voltage	± 5 % of rated voltage	
Setting tolerance	-	-	
Repeat accuracy	≤ 2 %	≤ 2 %	
Voltage influence	-	-	
Temperature influence	≤ 1 %	≤ 1 %	

#### Connection diagram

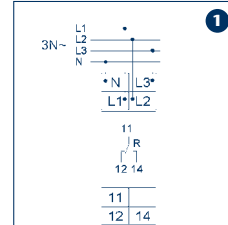

#### Connection diagram

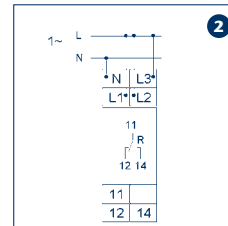

#### Legend:

**Yellow LED R ON/OFF:**  
Position of output relay  
**Green LED L1 ON/OFF:**  
Indication of voltage L1-N  
**Green LED L2 ON/OFF:**  
Indication of voltage L2-N  
**Green LED L3 ON/OFF:**  
Indication of voltage L3-N

**Output circuit**  
VA resistive load

# Star-delta switching relays SDR

## SDSR 1 | SDSR 2

### Specifications

#### Mechanical design

- Mount on TS 35
- Housing made of self-extinguishing plastic, IP40 protection
- Any mounting position possible
- Screw connections protected against accidental touch, according to VBG 4, IP20 protection

#### Screw connection

- 1 x 0.5 to 2.5 mm<sup>2</sup> with/without wire-end ferrules
- 1 x 4 mm<sup>2</sup> without wire-end ferrules
- 2 x 0.5 to 1.5 mm<sup>2</sup> with/without wire-end ferrules
- 2 x 2.5 mm<sup>2</sup> flexible without wire-end ferrules
- Tightening torque max. 1 Nm

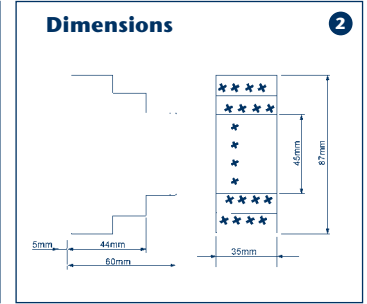
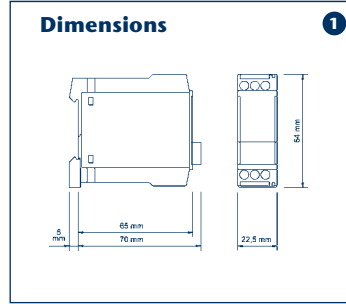



#### Environmental conditions

Ambient temperature	-25 to +55°C (acc. to IEC 68-1) -25 to +40°C (UL 508)
Storage temperature	-25 to +70°C
Transport temperature	-25 to +70°C
Relative humidity	15% to 85% (acc. to IEC 721-3-3 Class 3K3)
Pollution degree	2, in installed condition 3 (acc. to IEC 664-1)
Vibration resistance	10 to 55 Hz 0.35 mm (acc. to IEC 68-2-6)
Shock resistance	15 g 11 ms (acc. to IEC 68-2-27)

#### Description of function

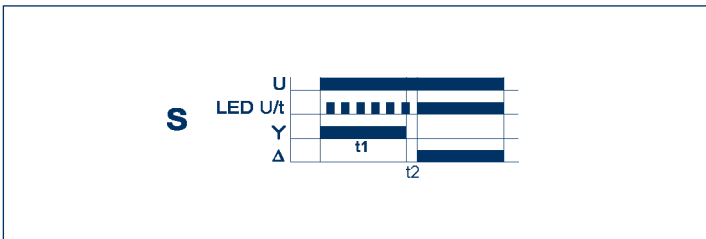
When supply voltage U is applied, the output relay for the star protection activates (yellow LED is lit), and the set star time (t1) begins to run (green LED U/t flashes). After the star time expires (green LED U/t is lit), the output relay for the star protection is deactivated (yellow LED is not lit), and the set transit time (t2) begins to run. After the transit time expires, the output relay for the delta protection activates. In order to re-start this function, the supply voltage must be interrupted and re-applied.



	SDSR 1	SDSR 2	
			
<b>Type</b>	<b>SDSR 1</b>	<b>SDSR 2</b>	
<b>Cat. no./Qty.</b>	<b>15776.2/1</b>	<b>15777.2/1</b>	
Dimensions	1	2	
Connection diagram	1	2	
Dimensions (L x W x H) TS 35 x 7.5	64 x 22.5 x 77.5 mm	87 x 35 x 67.5 mm	
Weight (individual packaging: module and packaging)	65 g	106 g	
<b>Short description</b>	<b>Star-delta start-up</b>	<b>Star-delta start-up</b>	
	2 NO	2 CO contact	
	Width 22.5 mm	Wide-range input	
	Industrial design	Width 35 mm	
		Installation design	
<b>Functions</b>			
	5 star-delta start-up	5 star-delta start-up	
<b>Time delay range</b>	<b>Time end range/setting range</b>	<b>Time end range/setting range</b>	
Star time	10 sec/500 ms to 10 sec 30 sec/1500 ms to 30 sec 1 min/3 sec to 1 min	10 sec/500 ms to 10 sec 30 sec/1500 ms to 30 sec 1 min/3 sec to 1 min	
<b>Transit time (fast)</b>			
	40 ms	40 ms	
	60 ms	60 ms	
	80 ms	80 ms	
	100 ms	100 ms	
<b>Display</b>			
	Green LED ON*	Green LED ON*	
	Green LED flashes*	Green LED flashes*	
	Yellow LED R ON/OFF*	Yellow LED R ON/OFF*	
<b>Supply circuit</b>			
Supply voltage	24 V DC, terminals A1(+)-A2(-), switch engaged 24 V DC, terminals A1-A2, Switch engaged 110 to 240 V AC, terminals A1-A2, switch dis-engaged	12 to 240 V AC/DC terminals A1(+)-A2(-)	
Tolerance	24 V DC $\pm 10\%$ 24 V AC -15% to +10% 110 to 240 VAC -15% to +10%	12 V -10% to 240 V +10%	
Rated frequency	48 to 63 Hz	48 to 63 Hz	
Rated consumption	24 V AC/DC 1.5 VA (1 W) 110 V AC/DC 2 VA (1 W) 240 V AC 8 VA (1.3W)	4 VA (1.5 W)	
ON duration	100%	100%	
Recovery time	100 ms	100 ms	
Residual ripple with DC	10%	10%	
Release voltage	> 30 % of the min. supply voltage	> 30 % of the min. supply voltage	
Overvoltage category	III (acc. to IEC 664-1)	III (acc. to IEC 664-1)	
Rated impulse voltage	4 kV	4 kV	
<b>Output circuit</b>			
Rated voltage	250 V AC	250 V AC	
Switching capacity of module mounted side-by-side (gap < 5 mm)	1250 VA (5A/250V AC)	2000 VA (8A/250V AC)	
Switching capacity of module not mounted side-by-side (gap < 5 mm)	2000 VA (8A/250V AC)	2000 VA (8A/250V AC)	
Fusing	8A fast	8A fast	
Mechanical life span	20 x 10 <sup>6</sup> switching cycles	20 x 10 <sup>6</sup> switching cycles	
Electrical service life	2 x 10 <sup>5</sup> switching cycles at 1000 VA resistive load	2 x 10 <sup>5</sup> switching cycles at 1000 VA resistive load	
Switching frequency	Max. 60/min at 100 VA resistive load Max. 6/min at 1000 VA resistive load (acc. to IEC 947-5-1)	Max. 60/min at 100 VA resistive load Max. 6/min at 1000 VA resistive load (acc. to IEC 947-5-1)	
Rated insulation voltage	250 VAC (acc. to IEC 664-1)	250 VAC (acc. to IEC 664-1)	
Overvoltage category	III (acc. to IEC 664-1)	III (acc. to IEC 664-1)	
Rated impulse voltage	4 kV	4 kV	
<b>Accuracy</b>			
Basic accuracy	$\pm 1\%$ (from scale reading)	$\pm 1\%$ (from scale reading)	
Setting tolerance	$\leq 25\%$ (from scale reading)	$\leq 25\%$ (from scale reading)	
Repeat accuracy	< 0.5% or $\pm 5$ ms	< 0.5% or $\pm 5$ ms	
Voltage influence	-	-	
Temperature influence	$\leq 20.01\%$ /°C	$\leq 20.01\%$ /°C	

#### Connection diagram

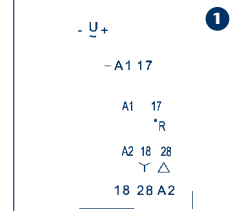

#### Connection diagram

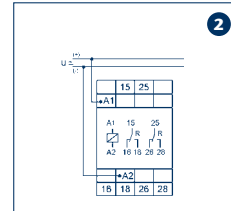

#### Legend:

**Green LED ON\*:**  
Supply voltage activated  
Output relay for delta protection is activated

**Green LED flashes\*:**  
Indicates expiration of star time

**Yellow LED R ON/OFF\*:**  
Position of output relay for star protection

# Voltage-monitoring relay VMR

## VMR 1 | VMR 2

The new voltage-monitoring relays conveniently monitor three-phase systems with and without a neutral wire. By precisely capturing characteristic values, they ensure the accessibility and reliability of a facility or machine. And in doing so, they deliver long-term added value. When operating facilities such as pumps and machines, it is critical to monitor the phase sequence, phase loss and asymmetry. Monitoring allows safe operation and prevents damage in a simple and efficient way. The power for the devices is supplied from the monitored measurement circuit. Thus the relays can easily and punctually record any irregularities in the three-phase supply systems, such as single-phase operations resulting from mains malfunctions which can lead to overheated motors. They notify of the need for maintenance or repair steps before further costs are incurred.

### Application areas:

- Monitoring the connection for mobile equipment (construction equipment, agricultural devices, refrigerated vehicles)
- For the protection of people and facilities – monitoring for reversal of rotation direction (for hoisting equipment, conveyor systems, elevators, escalators, etc.)
- Monitoring of sensitive systems
- Protection from the effects of passing temporary loads (loss of phase)
- Switching from normal to spare systems

### Screw connection

- 1 x 0.5 to 2.5 mm<sup>2</sup> with/without wire-end ferrules
- 1 x 4 mm<sup>2</sup> without wire-end ferrules
- 2 x 0.5 to 1.5 mm<sup>2</sup> with/without wire-end ferrules
- 2 x 2.5 mm<sup>2</sup> flexible without wire-end ferrules
- Tightening torque max. 1 Nm

### Dimensions

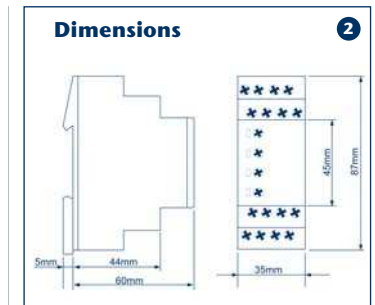

### Environmental conditions

Ambient temperature	-25 to +55°C (acc. to IEC 68-1) -25 to +40°C (UL 508)
Storage temperature	-25 to +70°C
Transport temperature	-25 to +70°C
Relative humidity	15 % to 85 % (acc. to IEC 721-3-3 Class 3K3)
Pollution degree	3 (acc. to IEC 664-1)
Vibration resistance	10 to 55 Hz 0.35 mm (acc. to IEC 68-2-6)
Shock resistance	15 g 11 ms (acc. to IEC 68-2-27)

### Description of function

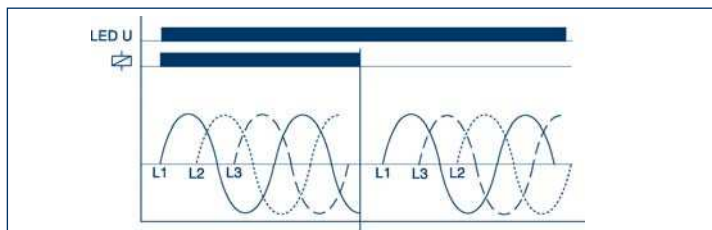

### Monitoring of phase sequence

If all phase are connected correctly and the voltage asymmetry is smaller than the defined set value, then the output relay R activates (yellow LED illuminated). If the rotational direction of the phase sequence changes, then the output relay R deactivates (yellow LED not illuminated).

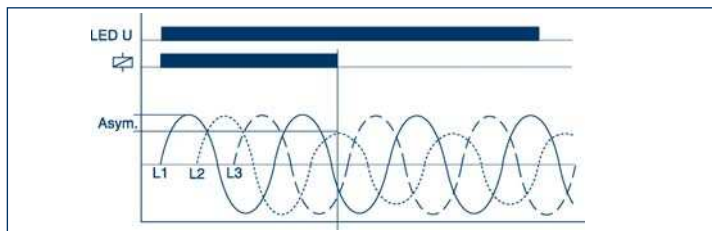

### Monitoring asymmetry

The output relay R is deactivated (the yellow LED is not illuminated) when the asymmetry exceeds the set value on the ASYM controller. The shut-off also takes place when the asymmetry is caused by inverse voltage from motors running on two phases.

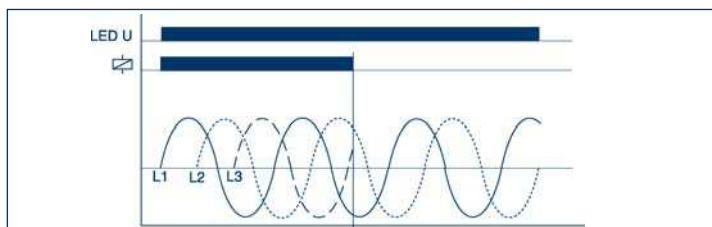

### Monitoring for loss of phase

In the event of a phase loss, the output relay R deactivates (yellow LED is not illuminated).

# Voltage-monitoring relay VMR

- Mount on TS 35
- Housing made of self-extinguishing plastic, IP40 protection
- Any mounting position possible
- Screw connection terminals protected against accidental touch, acc. to VBG 4 IP 20 protection

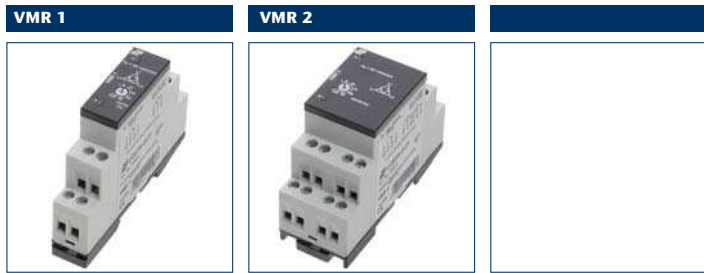

Type	VMR 1	VMR 2	
<b>Cat. no./Qty.</b>	15956.2/1	15957.2/1	
Dimensions	1	2	
Connection diagram	1	2	
Dimensions (L x W x H) TS 35 x 7,5	87 x 17,5 x 67,5 mm	87 x 35 x 67,5 mm	
Weight (individual packaging: module and packaging)	72 g	110 g	
<b>Short description</b>	Overvoltage monitoring in three-phase systems, monitoring for phase sequence and loss of phase Monitoring for asymmetrical connection of the neutral wire is optional; supply voltage = measuring-circuit voltage 1 CO contacts Width: 17,5 mm Installation design	Overvoltage monitoring in three-phase systems, monitoring for phase sequence and loss of phase Monitoring for asymmetrical connection of the neutral wire is optional; supply voltage = measuring-circuit voltage 2 CO contacts Width: 35 mm Installation design	
<b>Functions</b>	Monitoring asymmetry Monitoring for loss of phase	Monitoring asymmetry Monitoring for loss of phase	
<b>Time delay range</b>			
Triggering delay (quick)			
<b>Displays</b>			
Green LED ON			
Yellow LED ON/OFF	Position of output relay 1 min/3 s to 1 min	Position of output relay 1 min/3 s to 1 min	
<b>Supply circuit</b>			
Supply voltage	(N)-L1-L2-L3	(N)-L1-L2-L3	
Terminals	3(N)-400/230 V	3(N)-400/230 V	
Rated voltage UN	-30 % to +30 % of UN	-30 % to +30 % of UN	
Tolerance	8 VA (0.8 W)	11 VA (1.2 W)	
Rated consumption	AC 48 to 63 Hz	AC 48 to 63 Hz	
Rated frequency	100 %	100 %	
Power-on duration	500 ms	500 ms	
Recovery time	-	-	
Stored energy time	>20 % of supply voltage	>20 % of supply voltage	
Release voltage	III (acc. to IEC 60664-1)	III (acc. to IEC 60664-1)	
Overvoltage category	4 kV	6 kV	
Rated impulse voltage			
<b>Output circuit</b>			
Rated voltage	1250 VA (5 A/250 V AC)	1250 VA (5 A/250 V AC)	
Switching capacity	5 A fast	5 A fast	
Fusing	20 x 10 <sup>5</sup> switching cycles	20 x 10 <sup>5</sup> switching cycles	
Mechanical life span	2 x 10 <sup>5</sup> switching cycles at 1000 VA resistive load	2 x 10 <sup>5</sup> switching cycles at 1000 VA resistive load	
Electrical life span	Max. 60/min at 100 VA resistive load	Max. 60/min at 100 VA resistive load	
Switching frequency	Max. 6/min at 1000 VA resistive load (acc. to IEC 947-5-1) III (acc. to IEC 60664-1)	Max. 6/min at 1000 VA resistive load (acc. to IEC 947-5-1) III (acc. to IEC 60664-1)	
Overvoltage category	4 kV	6 kV	
Rated impulse voltage			
<b>Measurement circuit</b>			
Measured value	(= supply voltage)	(= supply voltage)	
Measurement input	(N)-L1-L2-L3	(N)-L1-L2-L3	
Terminals	Def. by tolerance of supply voltage	Def. by tolerance of supply voltage	
Overload capability	-	-	
Input resistance	5 % – 25 %	5 % – 25 %	
Asymmetry	III (acc. to IEC 60664-1)	III (acc. to IEC 60664-1)	
Overvoltage category	4 kV	6 kV	
Rated impulse voltage			
<b>Accuracy</b>			
Basic accuracy	≤5 %	≤5 %	
Setting tolerance	±2 %	±2 %	
Repeat accuracy	-	-	
Voltage influence	≤0.05 % / °C	≤0.05 % / °C	
Temperature influence			

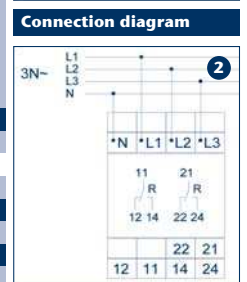
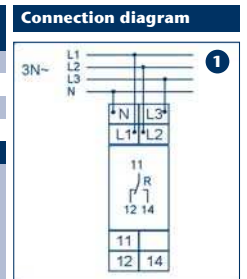

# Voltage-monitoring relay VMR

## VMR 3

The new **VMR 3** voltage-monitoring relay features professional monitoring of phase loss and phase sequence in three-phase and single-phase systems, with adjustable switching thresholds and triggering delay. The monitoring of the phase sequence, and thus the rotational direction of the phase sequence, is a very important function. A drive which is rotating incorrectly can lead to severe machine or system damage. In addition, this

component can monitor machines for possible surges or dips in the mains voltage. A breakage in a neutral wire can also be quickly, safely, and reliably detected. So the **VMR 3** is the compact solution for operating non-stationary machines securely and reliably, with a pluggable power supply from three-phase current.

### Screw connection

- 1 x 0.5 to 2.5 mm<sup>2</sup> with/without wire-end ferrules
- 1 x 4 mm<sup>2</sup> without wire-end ferrules
- 2 x 0.5 to 1.5 mm<sup>2</sup> with/without wire-end ferrules
- 2 x 2.5 mm<sup>2</sup> flexible without wire-end ferrules
- Tightening torque max. 1 Nm

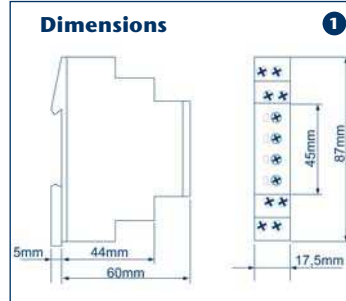

### Functional description

During all functions, if the minimum value for the measured voltage has been selected as a larger value than the maximum, then the Min and Max LEDs flash alternately (the relay is in off position). If a system error has occurred when activating the device, then the output relay remains off and the LED for the corresponding threshold illuminates. The device records every phase voltage (L-N) separately and monitors them according to the selection function (UNDER or WINDOW).

### Environmental conditions

Ambient temperature	-25 to +55°C (acc. to IEC 68-1) -25/+40°C (UL 508)
Storage temperature	-25 to +70°C
Transport temperature	-25 to +70°C
Relative humidity	15 % to 85 % (acc. to IEC 721-3-3 Class 3K3)
Pollution degree	3 (acc. to IEC 664-1)
Vibration resistance	10 to 55 Hz 0.35 mm (acc. to IEC 68-2-6)
Shock resistance	15 g 11 ms (acc. to IEC 68-2-27)

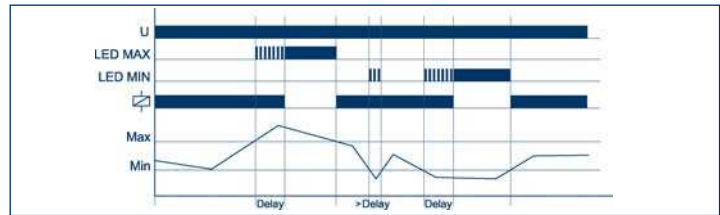
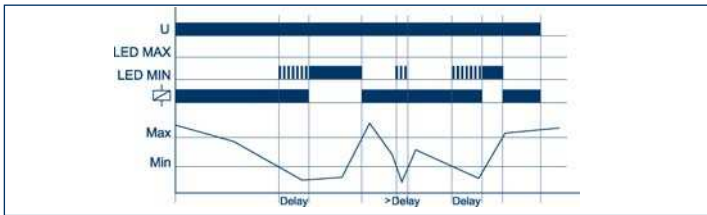

### Undervoltage monitoring (UNDER, UNDER+SEQ)

When the measured voltage (one of the phase voltages) falls under the value set at the Min controller, the set triggering delay time begins to run (the red LED Min flashes). The output relay R deactivates (yellow LED not illuminated) after the expiration of the delay time (red LED Min illuminated). If the measured voltage (all phase voltages) exceeds the value set at the Max controller, then the output relay R re-activates (yellow LED illuminated).

### Window function (WIN, WIN+SEQ)

The output relay R activates (yellow LED illuminated) when the measured voltage (all phase voltages) exceeds the set value on the Min controller. When the measured voltage (one of the phase voltages) exceeds the value set at the Max controller, the set triggering delay time begins to run (the red LED max flashes). The output relay R deactivates (yellow LED not illuminated) after the expiration of the delay time (red LED Max illuminated). The output relay re-activates (yellow LED illuminated) when the measured voltage once again falls below the maximum value (red LED Max not illuminated). When the measured voltage (one of the phase voltages) falls under the value set at the Min controller, the set triggering delay time begins to run (the red LED Min flashes). The output relay R deactivates (yellow LED not illuminated) after the expiration of the delay time (red LED Min illuminated).

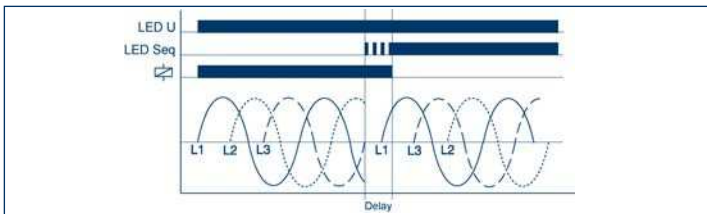

### Monitoring the phase sequence (SEQ)

The monitoring of the phase sequence is selectable for all functions. For single-phase circuits, monitoring of the phase sequence must be turned off. When the rotation direction of the phase changes (red LED SEQ illuminated), the output relay R is deactivated (yellow LED not illuminated) after the triggering delay time expires.

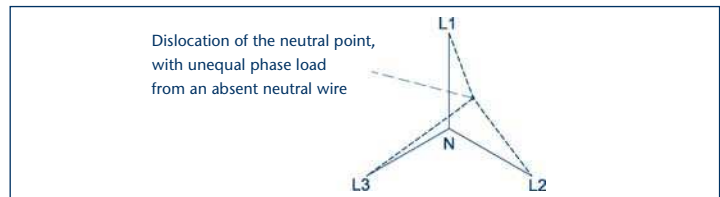

### Neutral wire break

The device monitors each phase (L1, L2 and L3) in reference to N. An asymmetrical phase load and a neutral wire breakage in the mains line will result in a dislocation of the neutral point. When one of the phase voltage exceeds the set shutdown threshold (Min or Max), the triggering delay then begins to run (red LED Min or Max flashes). The output relay R deactivates (yellow LED not illuminated) after the expiration of the delay time (red LED Max or Min illuminated).

# Voltage-monitoring relay VMR

- Mount on TS 35
- Housing made of self-extinguishing plastic, IP40 protection
- Any mounting position possible
- Screw connection terminals protected against accidental touch acc. to VBG 4 IP 20 protection

## VMR 3



<b>Type</b>	<b>VMR 3</b>
<b>Cat. no./Qty.</b>	<b>15958.2/1</b>
Dimensions	1
Connection diagram	1, 2
Dimensions (L x W x H) TS 35 x 7,5	87 x 17,5 x 67,5 mm
Weight (individual packaging:module and packaging)	72 g
<b>Short description</b>	Voltage monitoring in three-phase and single-phase systems, multi-function, monitoring for phase loss, monitoring for phase sequence selectable, Monitoring for asymmetrical connection of the neutral wire is optional; 1 CO contact, Width: 17.5 mm Installation design
<b>Functions</b>	Undervoltage monitoring, under-voltage and phase sequence monitoring
UNDER	Monitoring of the range between the Min and Max.
UNDER+SEQ	Monitoring of the range between the thresholds Min and Max and phase sequence monitoring
WIN	
WIN+SEQ	

<b>Time delay range</b>	<b>Setting range</b>
Start-up override	-
Output delay	0.1 s 10 s
<b>Displays</b>	Display error for corr. threshold.
Red LED ON/OFF	Display of triggering delay for corr. threshold
Red LED flashing	Position of output relay
Yellow LED ON/OFF	
<b>Supply circuit</b>	(= measuring-circuit voltage)
Supply voltage	(N)-L1-L2-L3
Terminals	3(N)-400/230 V
Rated voltage UN	-30 % to +30 % of Un
Tolerance	8 VA (1 W)
Rated consumption	AC 48 to 63 Hz
Rated frequency	100 %
Power-on duration	500 ms
Recovery time	-
Stored energy time	>20 % of supply voltage
Release voltage	III (acc. to IEC 60664-1)
Overvoltage category	4 kV
Rated impulse voltage	<b>Output circuit</b>
	1 potential-free CO contact
	Rated voltage
	250 V AC
	Switching capacity
	1250 VA (5 A / 250 V AC)
	Fusing
	5 A fast
	Mechanical life span
	20 x 10 <sup>6</sup> switching cycles
	Electrical life span
	2 x 10 <sup>5</sup> switching cycles at 1000 VA resistive load
	Switching frequency
	Max. 60/min at 100 VA resistive load
	Max. 6/min at 1000 VA resistive load (acc. to IEC 947-5-1)
	Overvoltage category
	III (acc. to IEC 60664-1)
	Rated impulse voltage
	4 kV
	<b>Measurement circuit</b>
	Measured value
	3(N)-, Sinus, 48 to 63 Hz
	Measurement input
	(= supply voltage)
	Terminals
	(N)-L1-L2-L3
	Overload capability
	Def. by tolerance of supply voltage
	Input resistance
	80 %–130 % of UN
	Asymmetry
	70 %–120 % of UN
	Overvoltage category
	III (acc. to IEC 60664-1)
	Rated impulse voltage
	4 kV
	<b>Accuracy</b>
	Basic accuracy
	±5% of scale limit
	Setting tolerance
	≤5 % of scale limit
	Repeat accuracy
	≤2 %
	Voltage influence
	-
	Temperature influence
	≤1 %

## Connection diagram

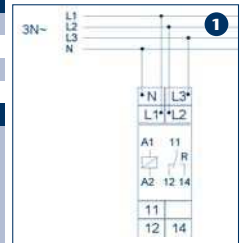

## Connection diagram

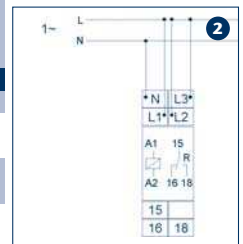

**CONTA-CONNECT**  
[Connection Systems]

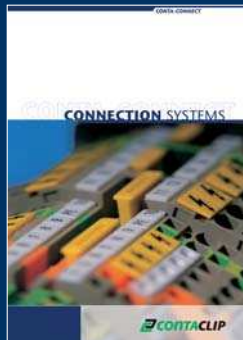

**CONTA-ELECTRONICS**  
[Electronics]

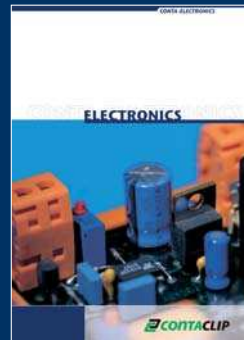

**CONTA-CON**  
[PCB Connectors]



www.kontor-media.de EN 10|11 All rights reserved.



Otto-Hahn-Str. 7  
D-33161 Hövelhof

Fon +49 (0) 52 57 . 98 33-0  
Fax +49 (0) 52 57 . 98 33-33

info@conta-clip.com  
www.conta-clip.com