

THESE DRAWINGS ARE THE PROPERTY OF QUALTEK ELECTRONICS AND NOT TO BE REPRODUCED FOR OR COMMUNICATED TO A THIRD PARTY WITHOUT THE EXPRESS WRITTEN PERMISSION OF AN OFFICER OF QUALTEK ELECTRONICS.

REVISION			
REV.	DESCRIPTION	DATE	APPROVED
B	RoHS Compliancy	06-01-06	DP
C	Updated Approvals	07-18-08	DP

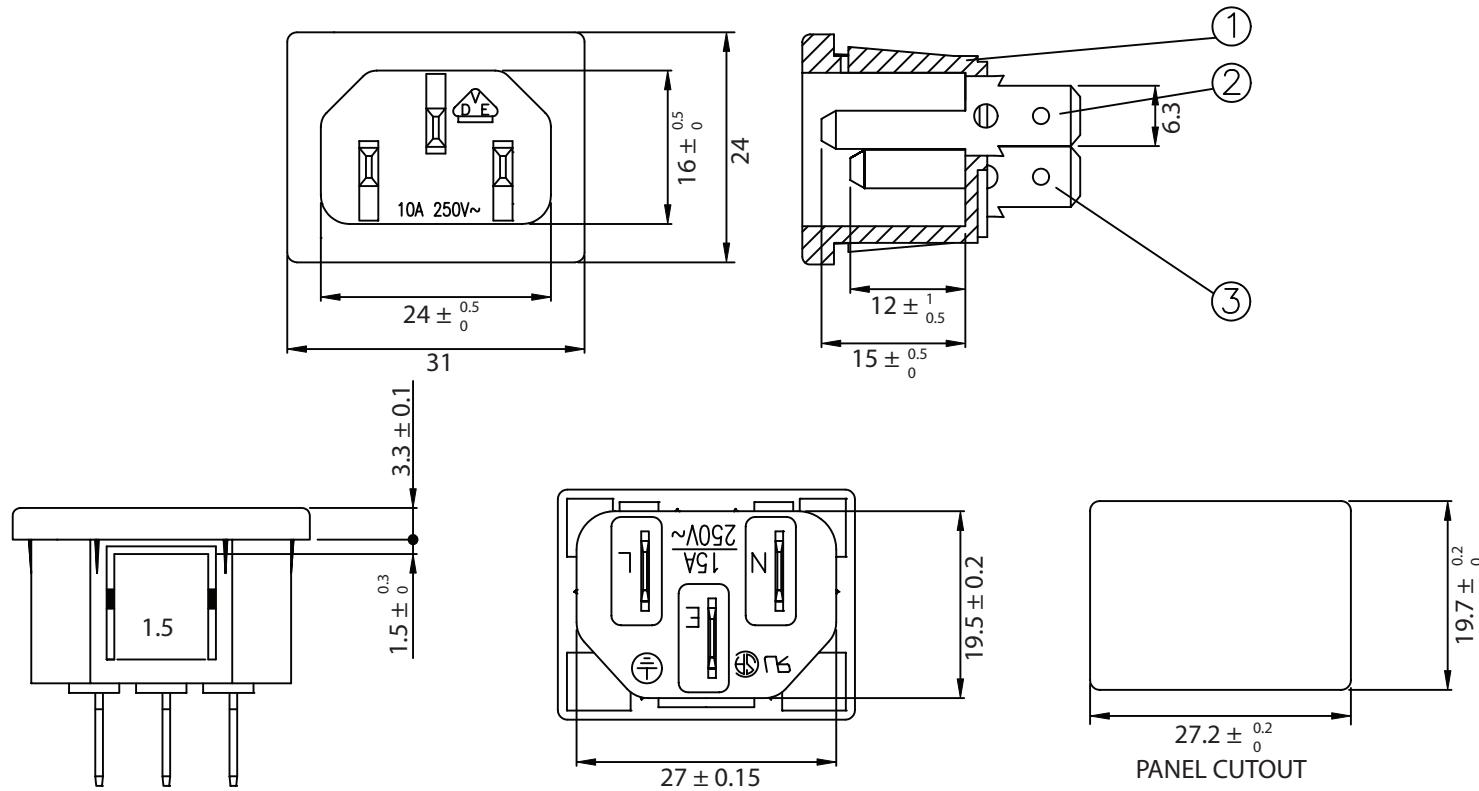

CONTROLLED

NOTES:

RATING:

UL, CSA: 15A 250V AC
 VDE: 10A 250V AC
 APPROVALS: UL, CSA, VDE, CCC
 PANEL THICKNESS: 1.5mm
 RoHS COMPLIANT

3	Contact PIN Bronze Strip t=2mm Tin-Plated	2
2	Contact PIN Bronze Strip t=2mm Tin-Plated	1
1	Body Insulator PC 940A Black Color	1

Dim range (mm)	Tolerance +/- (mm)	Qualtek Electronics Corp. PPC DIVISION		
		Part Number:	701W-15/31	RoHS Compliant
0-1	0.15	Description: SNAP-IN INLET		
1-6	0.20			
6-18	0.30			
18-50	0.50			
50-120	0.70	UNIT: mm	REV. C	
120-250	0.90	Drawn / Date	Checked / Date	Approved / Date
250-500	1.20	B.Zhang 06-06-02	06-06-02	JJH / 06-06-02