

THESE DRAWINGS ARE THE PROPERTY OF QUALTEK ELECTRONICS AND NOT TO BE REPRODUCED FOR OR COMMUNICATED TO A THIRD PARTY WITHOUT THE EXPRESS WRITTEN PERMISSION OF AN OFFICER OF QUALTEK ELECTRONICS.

REVISION			
REV.	DESCRIPTION	DATE	APPROVED
B	RoHS Compliancy	06-01-06	DP
C	Updated Specifications	12-20-07	DP

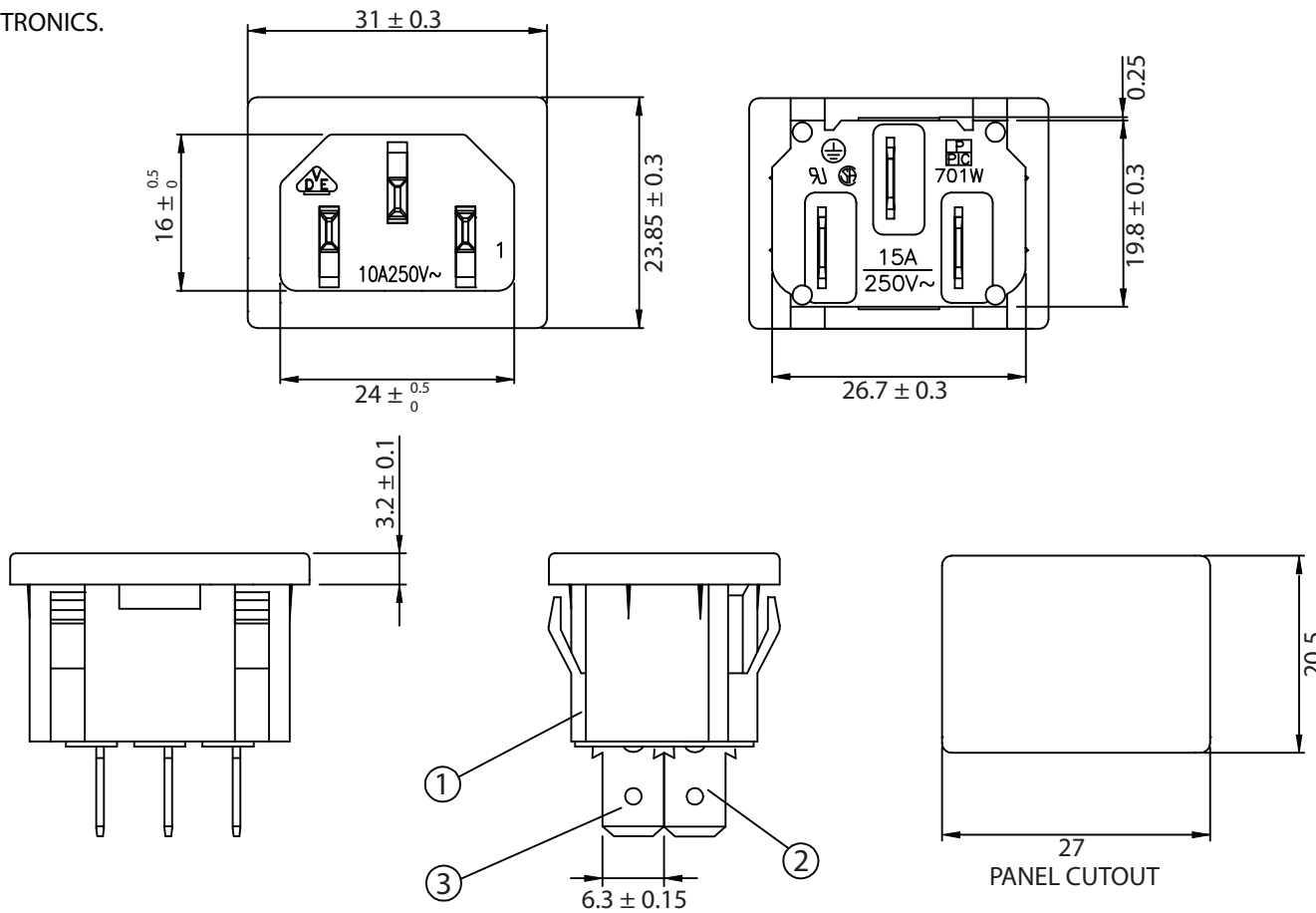

**CONTROLLED**

NOTES:

RATING:

UL, CSA: 15A 250V AC

VDE: 10A 250V AC

PANEL THICKNESS: 0.8mm~1.5mm

APPROVALS: UL, CSA, VDE

RoHS COMPLIANT

3	Contact PIN Bronze Strip t=2mm Ni-Plated	2
2	Contact PIN Bronze Strip t=2mm Ni-Plated	1
1	Body Insulator Nylon A216-BK	1

Dim range (mm)	Tolerance +/- (mm)	Qualtek Electronics Corp. PPC DIVISION		
		Part Number: 701W-X2/04	RoHS Compliant	
0-1	0.15	Description: AC RECEPTACLE		
1-6	0.20		UNIT: mm	REV. C
6-18	0.30			
18-50	0.50	Drawn / Date	Checked / Date	Approved / Date
50-120	0.70	B.Zhang 05-11-05	05-11-05	JJH / 05-11-05
120-250	0.90			
250-500	1.20			