

THESE DRAWINGS ARE THE PROPERTY OF QUALTEK ELECTRONICS AND NOT TO BE REPRODUCED FOR OR COMMUNICATED TO A THIRD PARTY WITHOUT THE EXPRESS WRITTEN PERMISSION OF AN OFFICER OF QUALTEK ELECTRONICS.

REVISION			
REV.	DESCRIPTION	DATE	APPROVED
B	RoHS Compliancy	06-01-06	DP

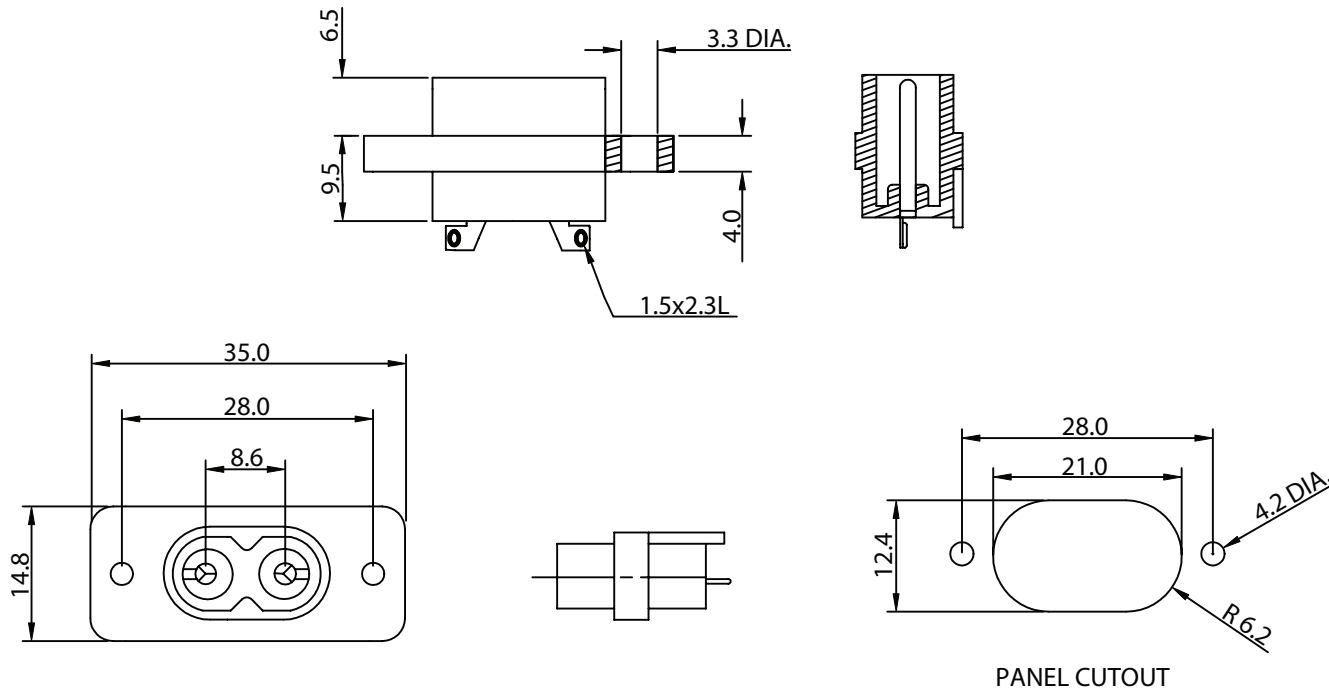

NOTES:

MATERIAL:

HOUSING: THERMOPLASTIC

TERMINAL: COPPER ALLOY

RATING: 2.5A 250V AC

INSULATION RESISTANCE: OVER 100 OHM 500V DC

DIELECTRIC STRENGTH: 2000V AC ONE MINUTE

APPROVALS: UL,CSA,VDE

RoHS COMPLIANT

CONTROLLED

Dim range (mm)	Tolerance +/- (mm)	Qualtek Electronics Corp. PPC DIVISION		
		Part Number:	770W-00/01	RoHS Compliant
0-1	0.15	Description: SCREW MOUNT C8 INLET		
1-6	0.20			
6-18	0.30			
18-50	0.50			
50-120	0.70	UNIT: mm	REV. B	
120-250	0.90	Drawn / Date	Checked / Date	Approved / Date
250-500	1.20	B.Zhang 10-28-03	10-28-03	JJH / 10-28-03