

THESE DRAWINGS ARE THE PROPERTY OF QUALTEK ELECTRONICS AND NOT TO BE REPRODUCED FOR OR COMMUNICATED TO A THIRD PARTY WITHOUT THE EXPRESS WRITTEN PERMISSION OF AN OFFICER OF QUALTEK ELECTRONICS.

REVISION			
REV.	DESCRIPTION	DATE	APPROVED
B	RoHS Compliancy	06-01-06	DP

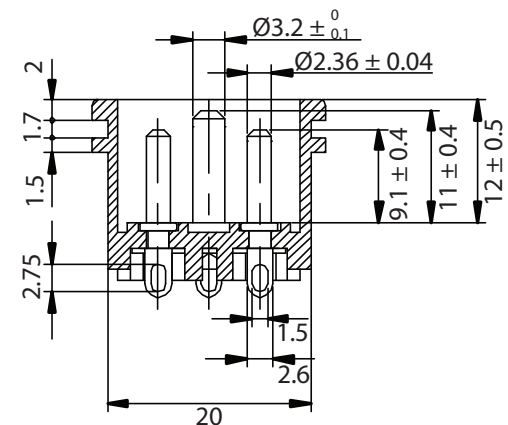
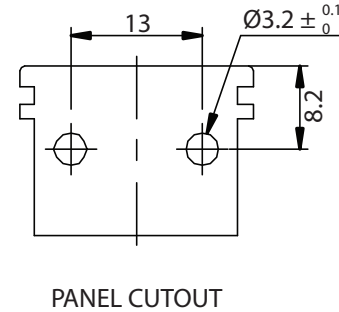
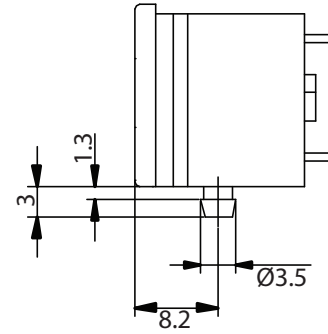
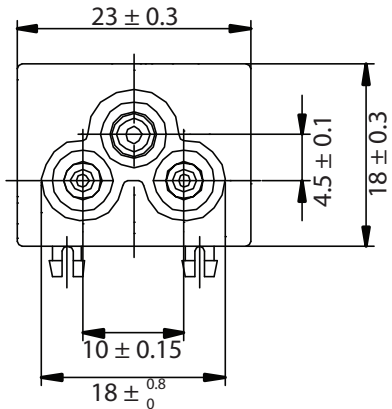
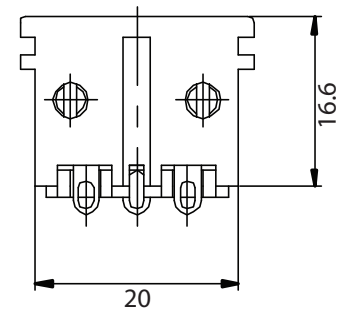
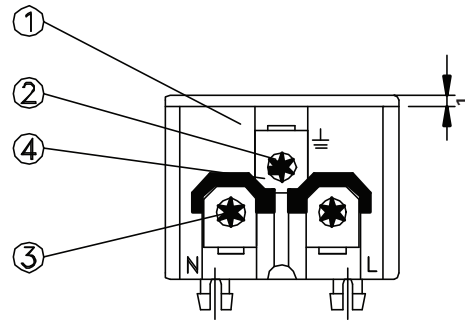
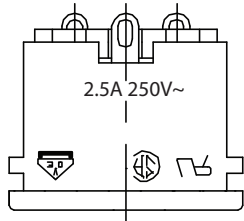

**CONTROLLED**

NOTES:

RATING: 2.5A 250V AC  
 APPROVALS: UL, CSA, VDE  
 RoHS COMPLIANT

4	Soldering PIN-TOP Bronze Strip t=0.5mm Tin-Plated	3
3	Solid Contact PIN Bronze Strip d=Ø2.36mm Ni-Plated	2
2	Solid Contact PIN Bronze Strip d=Ø3.2mm Ni-Plated	1
1	Body Insulator PC 940 Black Color	1

Dim range (mm)	Tolerance +/- (mm)	Qualtek Electronics Corp. PPC DIVISION		
		Part Number: 771W-CX2/01	RoHS Compliant	
0-1	0.15	Description: AC RECEPTACLE		
1-6	0.20		UNIT: mm	REV. B
6-18	0.30			
18-50	0.50			
50-120	0.70	Drawn / Date	Checked / Date	Approved / Date
120-250	0.90	B.Zhang 04-17-02	04-17-02	JJH / 04-17-02
250-500	1.20			