

**Model CK73041
Calibration Kit*****CK73041
CALIBRATION KIT***

The **POMONA CK73041 Calibration Kit** includes the major connectors and test cables you need for instrument calibration in a comprehensive kit. Versatile adapters and flexible cables greatly expand the variety of test cables you can create, reducing the number of special-purpose patch cords and connectors needed for calibration applications.

For data sheets / specifications of the individual components contained in the CK73041 Calibration Kit, please visit the POMONA website at:

www.pomonaelectronics.com

USA: Sales: 800-490-2361
Technical Support: technicalsupport@pomonatest.com
Fax: 425-446-5844
Europe: 31-(0) 40 2675 150 **International:** 425-446-5500
Where to Buy: www.pomonaelectronics.com

All dimensions are in inches. Tolerances (except noted): .xx = ± 0.02 " (.51 mm), .xxx = ± 0.005 " (.127 mm). All specifications are to the latest revisions. Specifications are subject to change without notice. Registered trademarks are the property of their respective companies.

**Model CK73041
Calibration Kit**

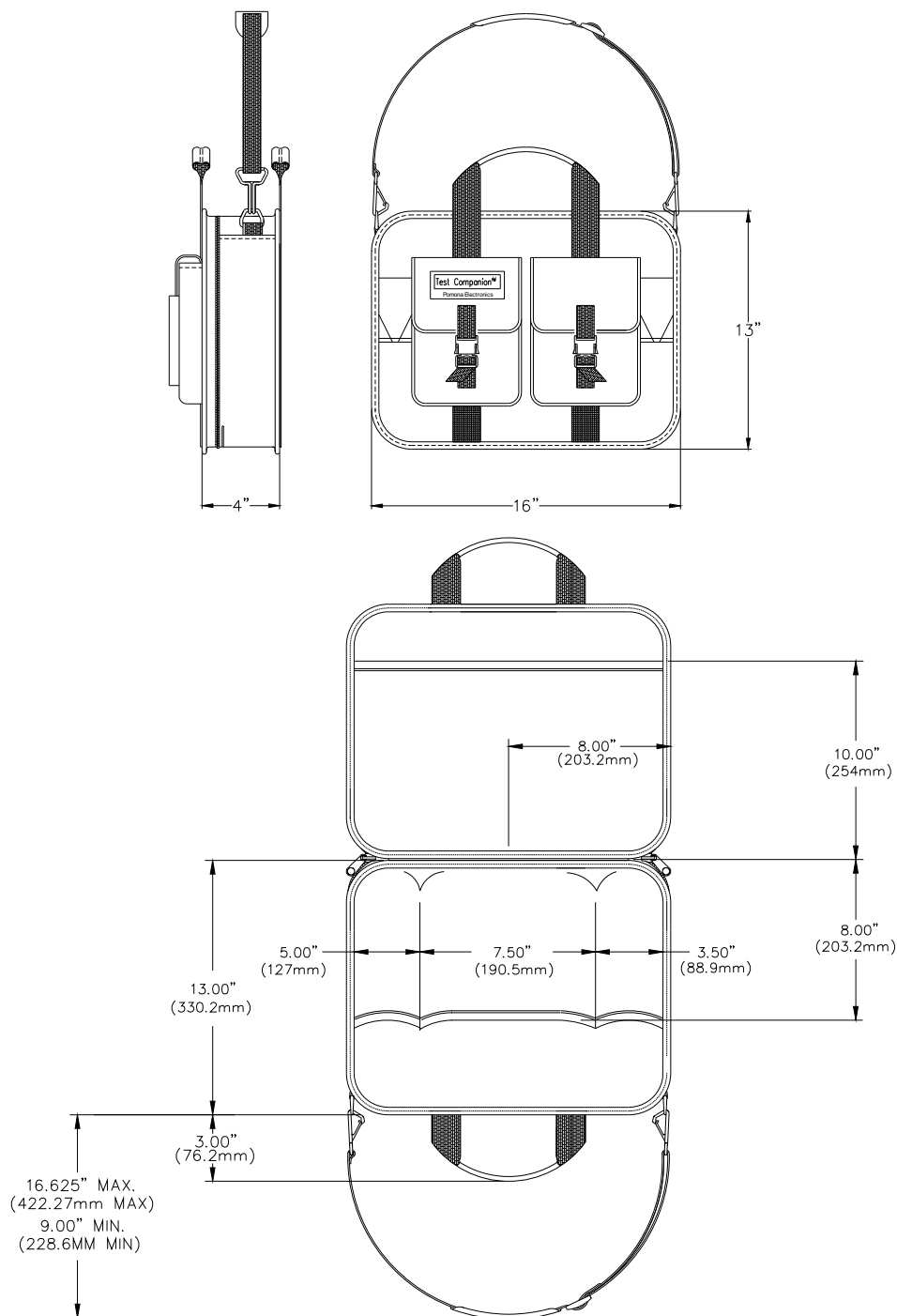

MODEL 6146
LARGE TEST COMPANION CARRYING CASE
QTY 1

USA: Sales: 800-490-2361
 Technical Support: technicalsupport@pomonatest.com
 Fax: 425-446-5844
Europe: 31-(0) 40 2675 150 **International:** 425-446-5500
Where to Buy: www.pomonaelectronics.com

All dimensions are in inches. Tolerances (except noted): .xx = ±.02" (.51 mm), .xxx = ±.005" (.127 mm). All specifications are to the latest revisions. Specifications are subject to change without notice. Registered trademarks are the property of their respective companies.

**Model CK73041
Calibration Kit**

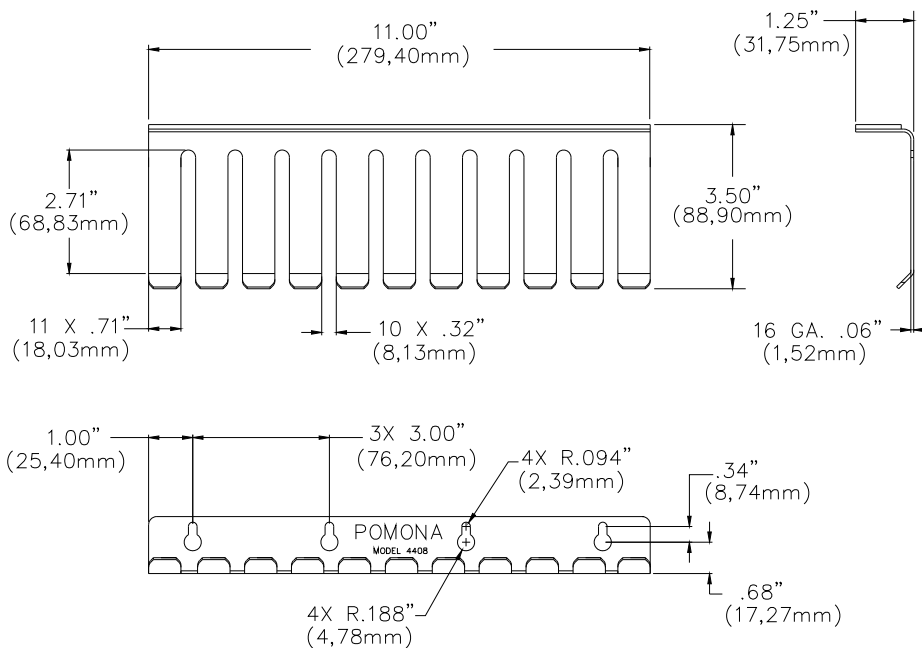

MODEL 4408
TEST LEAD HOLDER
QTY 1



MODEL HB-*
PATCH CORD SINGLE STACKING BANANA PLUG
QTY 4: 2 BLACK, 2 RED

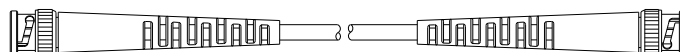

MODEL 2249
BNC (M), RG58C/U
QTY 4

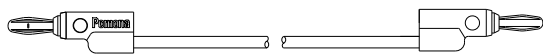

MODEL B-*
PATCH CORD SINGLE STACKING BANANA
QTY 8: 4 BLACK, 4 RED

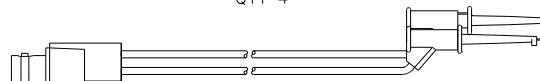

MODEL 5188
BREAKOUT BNC (F) TO MICROGRABBER
QTY 1:

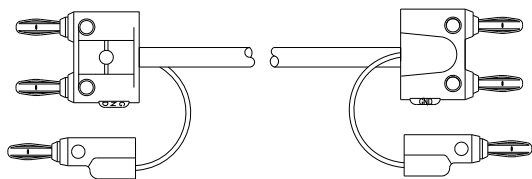

MODEL 1167
PATCH CORD DOUBLE BANANA PLUG
QTY 2

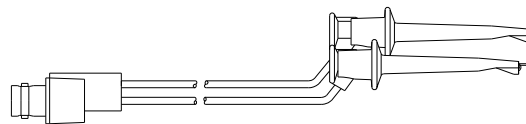

MODEL 3788
BREAKOUT BNC (F) TO MINIGRABBER
QTY 1:

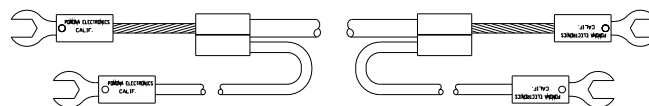

MODEL 1756
MICROVOLT SPADE LUG, SHIELDED
QTY 2

USA: Sales: 800-490-2361
Technical Support: technicalsupport@pomonatest.com
Fax: 425-446-5844
Europe: 31-(0) 40 2675 150 **International:** 425-446-5500
Where to Buy: www.pomonaelectronics.com

All dimensions are in inches. Tolerances (except noted): .xx = ±.02" (.51 mm), .xxx = ±.005" (.127 mm). All specifications are to the latest revisions. Specifications are subject to change without notice. Registered trademarks are the property of their respective companies.

**Model CK73041
Calibration Kit**

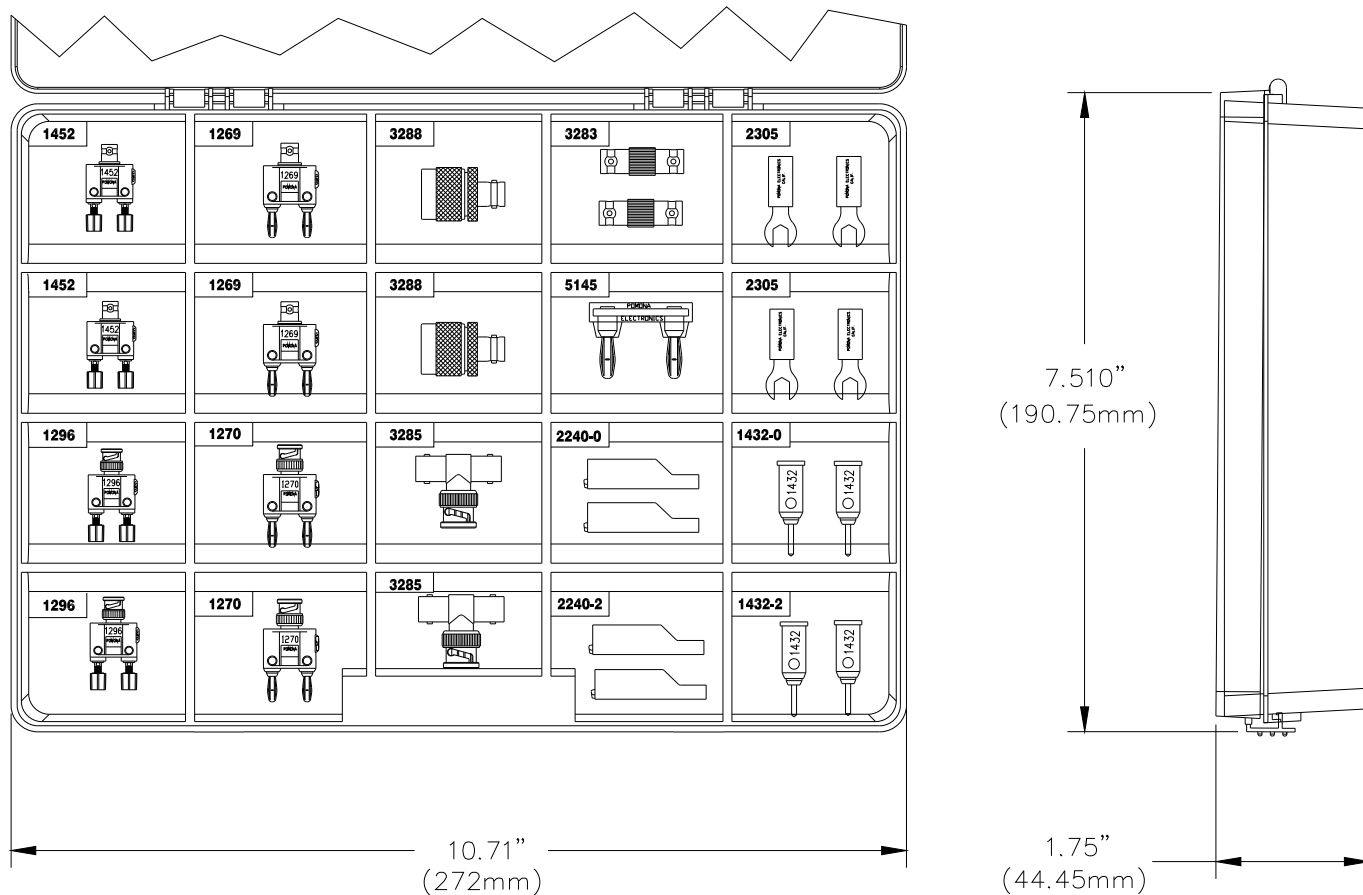

Features

- **Perfect for:**
 - Field Calibration
 - Outfitting a new technician or lab
 - Comprehensive replacement of important connectors and leads
- **The Calibration Kit allows you to:**
 - Combine connectors with patch cords to create a wide variety of necessary test cables.
 - Reduce the number of test cables needed by creating multiple combinations.
 - Make low voltage precision measurements with shielded low thermal EMF spade lug patch cords.
 - Easily connect to a variety of test equipment with BNC to banana and BNC to binding post adapters.
 - Use shielded coax cables for test and calibration rather than unshielded leads.
 - Turn banana plug patch cords into test leads terminated with alligator clips, spade lugs, or pin tips.
 - Access N Type instrument jacks.
 - Connect to analog components from coaxial cables.
 - Take advantage of shielded dual conductor patch cords.
 - Daisy-chain leads for those long lead situations.

USA: Sales: 800-490-2361
 Technical Support: technicalsupport@pomonatest.com
 Fax: 425-446-5844

Europe: 31-(0) 40 2675 150 **International:** 425-446-5500
Where to Buy: www.pomonaelectronics.com

All dimensions are in inches. Tolerances (except noted): .xx = ±.02" (.51 mm), .xxx = ±.005" (.127 mm). All specifications are to the latest revisions. Specifications are subject to change without notice. Registered trademarks are the property of their respective companies.

Model CK73041 Calibration Kit

- The **CK73041 CALIBRATION KIT** includes:

| Item | Model | Description | Quantity |
|------|------------------|---|----------|
| 1 | 6146 | LARGE TEST COMPANION CARRYING CASE | 1 |
| 2 | 4408 | TEST LEAD HOLDER | 1 |
| 3 | HB-36-0 | HORIZONTAL STACKING BANANA PLUG PATCH CORD, 36 INCHES (914.4 mm), BLACK | 2 |
| 4 | HB-36-2 | HORIZONTAL STACKING BANANA PLUG PATCH CORD, 36 INCHES (914.4 mm), RED | 2 |
| 5 | B-12-0 | STACKING BANANA PLUG PATCH CORD, 12 INCHES (304.8 mm), BLACK | 2 |
| 6 | B-12-2 | STACKING BANANA PLUG PATCH CORD, 12 INCHES (304.8 mm), RED | 2 |
| 7 | B-24-0 | STACKING BANANA PLUG PATCH CORD, 24 INCHES (609.6 mm), BLACK | 2 |
| 8 | B-24-2 | STACKING BANANA PLUG PATCH CORD, 24 INCHES (609.6 mm), RED | 2 |
| 9 | 1167-36 | DOUBLE BANANA PLUG ON SHIELDED BALANCE LINE, 36 INCHES (914.4 mm) | 2 |
| 10 | 1756-48 | SHIELDED LOW VOLTAGE SPADE LUG PATCH CORD, 48 INCHES (1219.2 mm) | 2 |
| 11 | 2249-C-36 | BNC (M) RG58C/U RF CABLE, 36 INCHES (914.4 mm) | 4 |
| 12 | 5188 | BNC (F) TO MICROGRABBER TEST CLIPS | 1 |
| 13 | 3788 | BNC (F) TO MINIGRABBER TEST CLIPS | 1 |
| 14 | 1269 | BNC (F) / DOUBLE BANANA PLUG ADAPTER | 2 |
| 15 | 1270 | BNC (M) / DOUBLE BANANA PLUG ADAPTER | 2 |
| 16 | 1452 | BNC (F) / DOUBLE BINDING POST ADAPTER | 2 |
| 17 | 1296 | BNC (M) / DOUBLE BINDING POST ADAPTER | 2 |
| 18 | 2305 | SET OF BLACK AND RED MICROVOLT SPADE LUG / BANANA JACK ADAPTER | 2 (SETS) |
| 19 | 2240-0 | ALLIGATOR CLIP / BANANA JACK ADAPTER, BLACK | 2* |
| 20 | 2240-2 | ALLIGATOR CLIP / BANANA JACK ADAPTER, RED | 2* |
| 21 | 1432-0 | PIN TIP / BANANA JACK ADAPTER, BLACK | 2* |
| 22 | 1432-2 | PIN TIP / BANANA JACK ADAPTER, RED | 2* |
| 23 | 3283 | BNC (F-F) ADAPTER | 2 |
| 24 | 3285 | BNC (F-M-F) T ADAPTER | 2 |
| 25 | 3288 | BNC (F) / N TYPE (M) ADAPTER | 2 |
| 26 | 5145 | DOUBLE BANANA PLUG SHORTING BAR, INSULATED | 1 |

* The model number refers to the standard item which is sold in 10 per package. However, the CK73041 contains only 2 pieces of the item.

Ordering Information

Model: **CK73041**
CALIBRATION KIT

USA: Sales: 800-490-2361
Technical Support: technicalsupport@pomonatest.com
Fax: 425-446-5844

Europe: 31-(0) 40 2675 150 **International:** 425-446-5500

Where to Buy: www.pomonaelectronics.com

All dimensions are in inches. Tolerances (except noted): .xx = ±.02" (.51 mm), .xxx = ±.005" (.127 mm). All specifications are to the latest revisions. Specifications are subject to change without notice. Registered trademarks are the property of their respective companies.