

Models 5117A
XLR (M) 3-Pin Rectangular Flanged Panel Mount

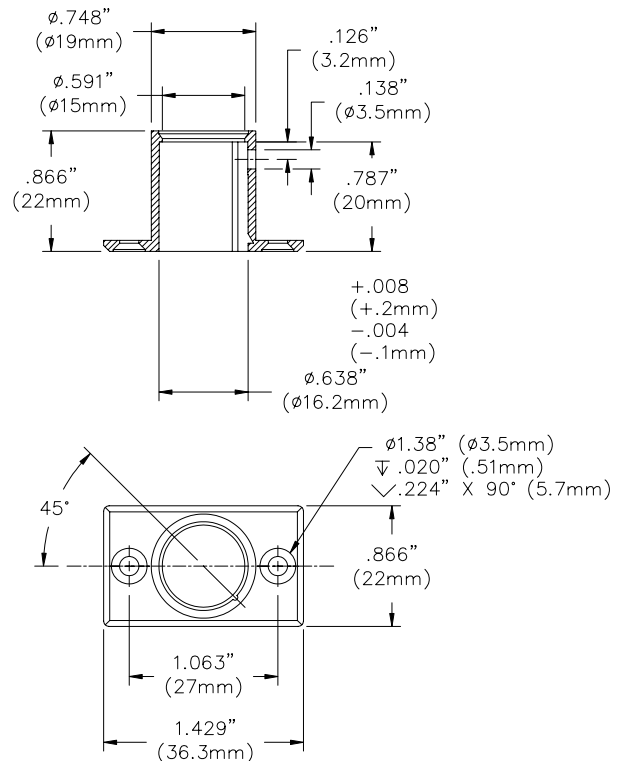

Model 5117A XLR (M) 3-Pin Rectangular Flanged Mount



Protect contacts and absorb vibrations in your audio applications

Features

- 3-pin XLR panel mount with sturdy all metal one piece design
- Solder cup terminations
- Low contact resistance
- Front mountable

Materials

- Housing is die cast zinc alloy with tarnish resistant nickel plating.
- Contacts are brass with nickel finish (Ground tab is steel).

Ordering Information

Model: 5117A.

Specifications

Number of contacts	3
Contact resistance	< 5 m Ω
Dielectric strength	1500 V dc
Wire size (AWG)	14 AWG (2.5 mm ²) max.

USA: Sales: 800-490-2361 Technical Support: 800-241-2060 Fax: 888-403-3360

Europe: 31-(0) 40 2675 150 International: 425-446-5500

e-mail: technicalsupport@pomonatest.com

Where to Buy: www.pomonaelectronics.com

All dimensions are in inches. Tolerances (except noted): .xx = $\pm .02"$ ($.51\text{mm}$), .xxx = $\pm .005"$ ($.127\text{mm}$). All specifications are to the latest revisions. Specifications are subject to change without notice. Registered trademarks are the property of their respective companies.