



SignalSure

*Mid-power automotive  
LED signal solutions*

Technical Datasheet DS11



AEC-Q101  
Qualified

Meets SAE/ECE Automotive  
Color Requirements

# SignalSure

## Mid-Power LED Light Source

### Introduction

SignalSure is the small, lightweight, surface-mount, mid-power LED signaling solution available in red-orange and amber colors that deliver an elevated standard of light output, flux density, color uniformity and manufacturability. SignalSure's robust design structure, coupled with high performance specification, ensures high quality and reliability. SignalSure allows you to create unique automotive signal lighting designs.

### Use SignalSure in:

- Automotive exterior lighting
  - CHMSL
  - Side Marker
  - Mirror Turn
  - Stop
  - Tail
  - Rear Fog
- Motorcycle Signaling
- Commercial Vehicle Signaling

**PHILIPS**  
LUMILEDS

# Table of Contents

General Information.....	3
Product Nomenclature .....	3
Test Conditions for Optical Characteristics at Junction Temperature.....	3
Product Selection Guide .....	3
Reliability Testing.....	4
Electrostatic Discharge (ESD) Test.....	4
Maximum Ratings .....	4
Optical Characterization .....	5
Electrical Characterization .....	5
Temperature Characterization .....	5
Recommended Reflow Profile and Solder Pad.....	6
Reflow Soldering Characteristics.....	6
Mechanical Dimensions.....	7
Solder Pad Design .....	8
Performance Measurement.....	9
Typical Spatial Radiation Pattern .....	9
Typical Relative Luminous Flux.....	9
Red-Orange and Amber Luminous Flux vs. Junction Temperature.....	10
Typical Forward Current Characteristics .....	10
Current Derating Curves .....	11
Typical Wavelength Characteristics .....	11
Binning Specification.....	12
Luminous Flux Bin Definition .....	12
Bin Range Option Codes.....	12
Color Bin Definition and Dominant Wavelength .....	13
Forward Current ( $V_f$ ) Bin Definition.....	13
Packing Information.....	14
Pocket Tape Packaging .....	14
Reel Packaging.....	15
Product Labeling Information .....	15
CAT Code Label.....	16

# General Information

## Product Nomenclature

The part number designation is explained as follows:

S M D A B C - D E F G - x x y y y

Where:

SMD — designates the product type

ABC — designates the current bin (75 mA)

D — designates the package type (L = Lambertian)

E — designates the color (O = Red-Orange, A = Amber)

F — indicates the chip information, binning and packaging scheme

G — indicates the binning and testing scheme

xx — designates the minimum flux and bin code

yyy — option code (standard part number = 000)

## Test Conditions for Optical Characteristics at Junction Temperature

Philips Lumileds tests SignalSure emitters for 20ms integration time at  $T_j = 25^\circ\text{C}$ . This datasheet specifies performance at a constant temperature of  $25^\circ\text{C}$ , except where noted.

## Environmental Compliance

Philips Lumileds is committed to providing environmentally friendly products to the solid-state lighting market. SignalSure is compliant to the European Union directives on the restriction of hazardous substances in electronic equipment, namely the RoHS directive. Philips Lumileds will not intentionally add the following restricted materials to SignalSure: lead, mercury, cadmium, hexavalent chromium, polybrominated biphenyls (PBB) or polybrominated biphenyl ethers (PBDE).

## Product Selection Guide

Table 1.

LED Color	Part Number <sup>[1]</sup>	Drive Current Range	Typical Viewing Angle <sup>[2]</sup> (degrees) $2\theta_{1/2}$
Red-Orange	SMD075-LO8I	75 mA	120
Amber	SMD075-LA8I	75 mA	120

Notes for Table 1:

1. SignalSure test current is at 75 mA.
2.  $2\theta_{1/2}$  viewing angle is the off axis angle from lamp centerline where the luminous intensity is  $1/2$  of the peak value.

## Reliability Testing

Philips Lumileds conducts extensive reliability stress testing before the introduction of new products to ensure that they meet the reliability expectations of the automotive market. The development of SignalSure includes reliability test simulations for both high voltage (24V) jump start and high voltage (18V) alternator failure conditions to ensure LED survivability, performance and quality integrity as well as design margin allowance.

**Table 2.**

Parameter	Pre-test Condition	$I_f$ (mA)	SMD075	Stress Duration (minute)
			$T_a$ (°C)	
Current overstress	High Voltage (24V) Jump Start Simulation	150	55	5
	High Voltage (18V) Alternator Failure Simulation	100	55	120
Temperature overstress (Junction Temperature)			max 185°C	

## Electrostatic Discharge (ESD) Test

**Table 3.**

Electrostatic Discharge (ESD) Test	Test Conditions	Rating
Human Body Model	8000V, 3 positive pulses, 3 negative pulses	JEDEC Class 3B (AEC: Class H3A)
Machine Model	400V, 3 positive pulses, 3 negative pulses	JEDEC Class B (AEC: Class 3M)
Charged Device Model	1000V, 3 positive pulses, 3 negative pulses	JEDEC Class III (AEC : Class C4)

## Maximum Ratings, $T_j = 25^\circ\text{C}$

**Table 4.**

Parameter	Symbol	Rating	Units
DC Forward Current <sup>[1]</sup>	$I_F$	75	mA
Pulsed Forward Current	$I_{FP}$	150	mA
Thermal Resistance	$R_{th\ J-Solder\ point}$	120	°C /W (Max)
Ambient Operating Temperature Range	$T_a$	-40 ~ 110	°C
Storage Temperature Range	$T_{stg}$	-55 ~ 110	°C
DC Junction Temperature	$T_j$	135	°C
Moisture Sensitivity Level (MSL)	MSL	L1	-----
High Temperature Chamber <sup>[2]</sup>	T(125)	125 (2 hours)	°C

Notes for Table 4:

1. See derating charts for more information.
2. High temperature characterization at non powered condition.

## Optical Characterization, $T_j = 25^\circ\text{C}$ [2]

Table 5.

Part Number	Total Flux/Luminous Intensity (lm/cd) Typ.	Dominant Wavelength (nm) $\lambda_{\text{dom}}$ Typ.	Peak Dominant Wavelength (nm) $\lambda_{\text{peak}}$ Typ.	Typical Viewing Angle $2\theta_{1/2}$ (°) @ 50% intensity	Typical Total Included Angle $\theta_{90V}$ (°) [1]
SMD075-LO81	2.8	615	622	120 +/- 10	150 +/- 10
SMD075-LA81	2.8	590	593	120 +/- 10	150 +/- 10

Note for Table 5:

- I.  $\theta_{90V}$  is the included angle at which 90% of the total luminous flux is captured.

## Electrical Characterization

Table 6.

Parameter	Symbol	Rating	Units
Forward Voltage	$V_F$	2.8	V (Typ)
Thermal Resistance [1]	$R_{\text{th J-Ambient}}$	180	$^\circ\text{C/W}$ (Typ)
Capacitance $V_F=0$ , $F=1\text{MHz}$	C	25	pF (Typ)
Speed of Response Time Constant, $e^{-t}/\tau_s$	$\tau_s$	20	ns (Typ)

Note for Table 6:

- I.  $R_{\text{th J-Ambient}}$  obtained based on mounting on PCB FR4 pad size  $\geq 16\text{ mm}^2$  per pad.

## Temperature Characterization

Table 7.

Parameter	Symbol	Part Number	Value	Unit
Typical Temperature coefficient of $\lambda_{\text{dom}}$ $I_F = 75\text{ mA}$ , $10^\circ\text{C} \leq T_j \leq 85^\circ\text{C}$	$TC_{\lambda_{\text{dom}}}$	SMD075-LO81	0.05	nm/ $^\circ\text{C}$
		SMD075-LA81	0.09	
Typical Temperature coefficient of $V_F$ $I_F = 75\text{ mA}$ , $10^\circ\text{C} \leq T_j \leq 85^\circ\text{C}$	$TC_V$	SMD075-LO81	-2.1	mV/ $^\circ\text{C}$
		SMD075-LA81	-1.0	
Typical Temperature coefficient of $\phi_V$ $I_F = 75\text{ mA}$ , $10^\circ\text{C} \leq T_j \leq 85^\circ\text{C}$	$TC_{\phi}$	SMD075-LO81	-47.0	mIm/ $^\circ\text{C}$
		SMD075-LA81	-55.0	

# Recommended Reflow Profile and Solder Pad

## Reflow Soldering Characteristics

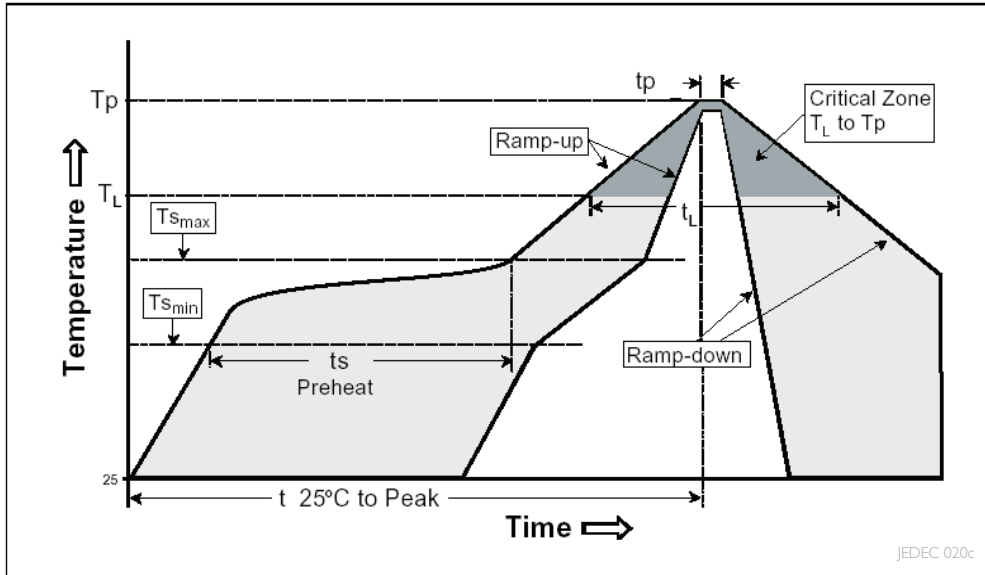

Figure 1. Temperature profile for Table 8.

Table 8.

Profile Feature	Lead Free Assembly
Average Ramp-Up Rate ( $T_{s_{max}}$ to $T_p$ )	3°C / second max
Preheat Temperature Min ( $T_{s_{min}}$ )	150°C
Preheat Temperature Max ( $T_{s_{max}}$ )	200°C
Preheat Time ( $t_{s_{min}}$ to $t_{s_{max}}$ )	60 - 120 seconds
Temperature ( $T_L$ )	217°C
Time Maintained Above Temperature $T_L$ ( $t_L$ )	60 - 150 seconds
Peak / Classification Temperature ( $T_p$ )	260°C
Time Within 5°C of Actual Peak Temperature ( $t_p$ )	10 - 30 seconds
Ramp-Down Rate	6°C / second max
Time 25°C to Peak Temperature	8 minutes max

Note for Table 8:

- All temperatures refer to the application Printed Circuit Board (PCB), measured on the surface adjacent to the package body.

## Mechanical Dimensions

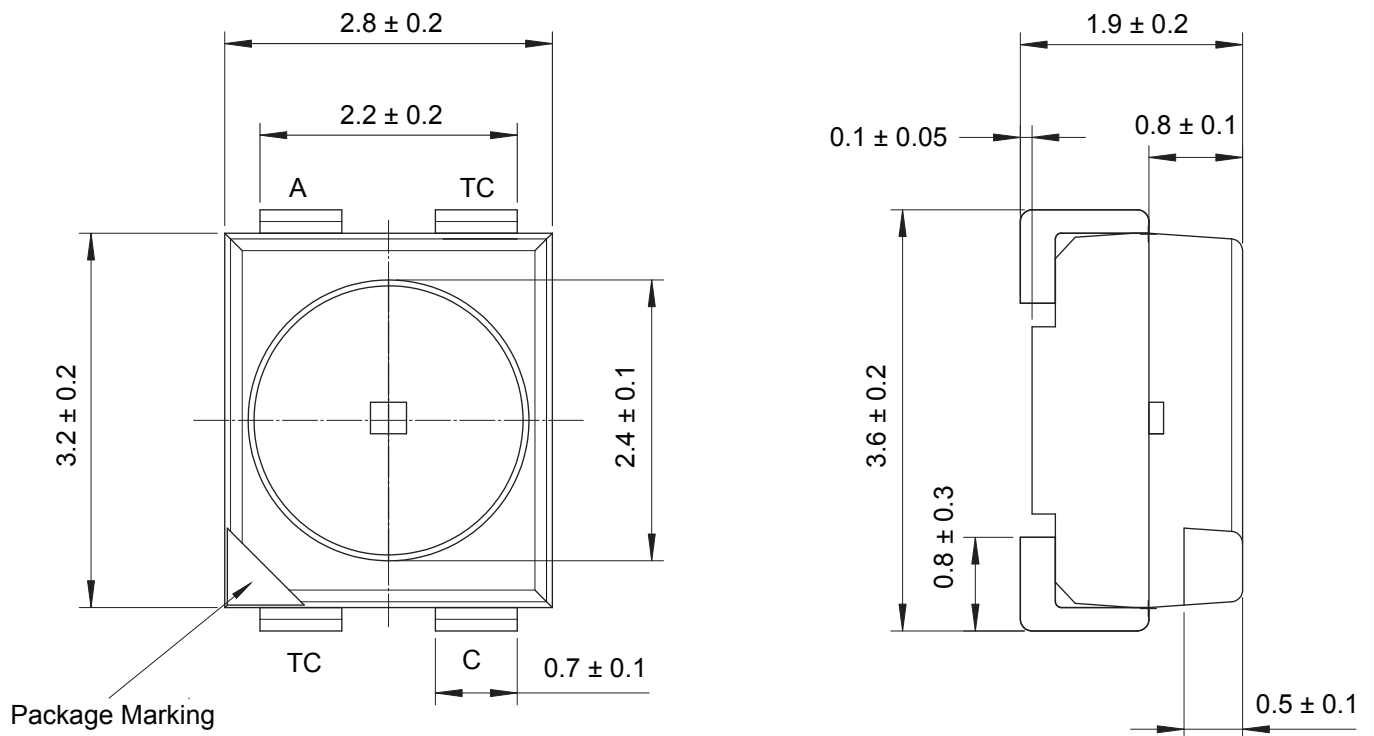
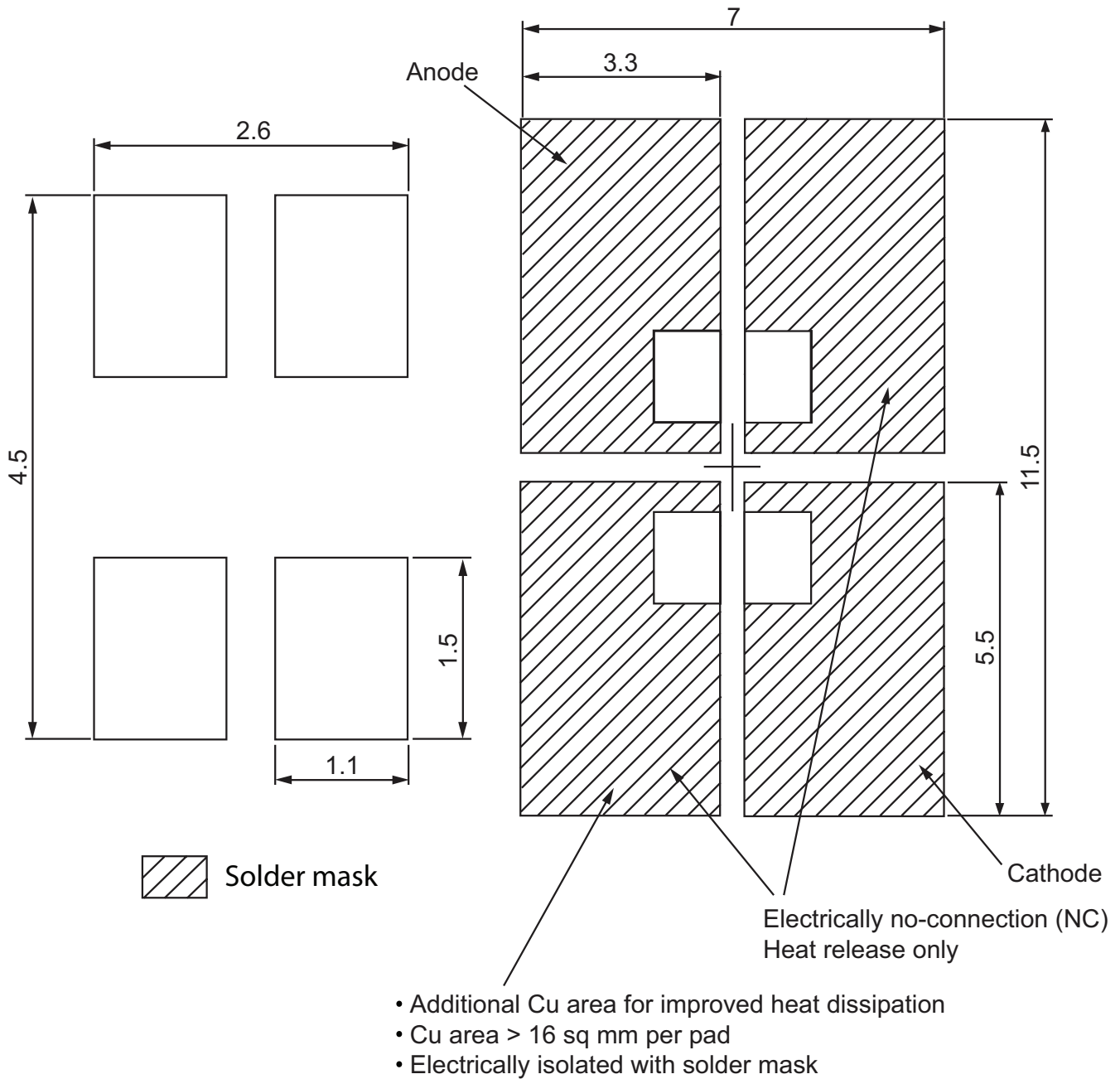

Figure 2.

### Notes for Figure 2:

- Dimensions are in millimeters.
- Cathode lead is indicated with a "C" and anode lead is indicated with an "A".
- "TC" is for thermal connection (image for illustration purpose).
- Optical focal point for illustration purposes only and not drawn to scale.

## Solder Pad Design



**Figure 3. Solder pad layout.**

Note for Figure 3:

- The drawing above shows the recommended SignalSure layout on Printed Circuit Board (PCB).

# Performance Measurement

## Typical Spatial Radiation Pattern

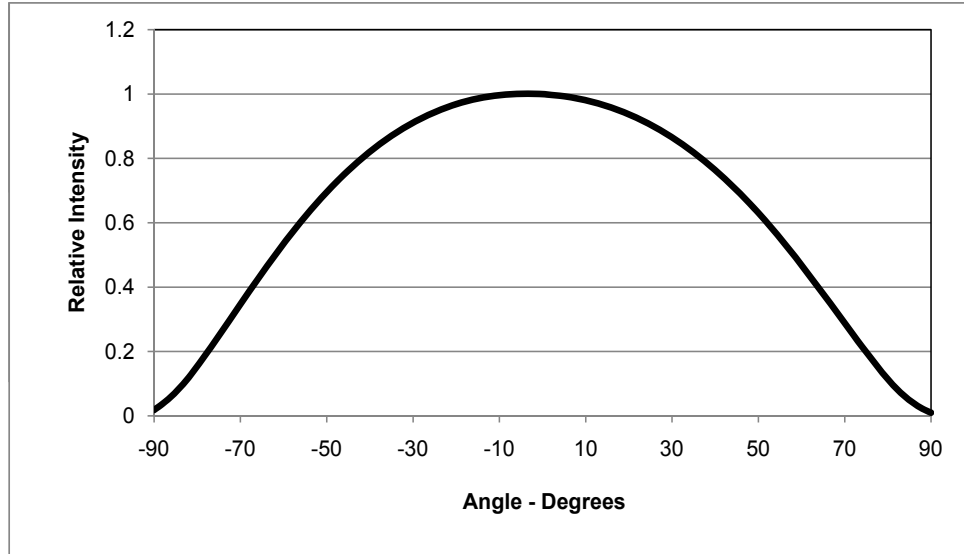

Figure 4. Typical spatial radiation pattern.

## Typical Relative Luminous Flux, Junction Temperature = 25°C

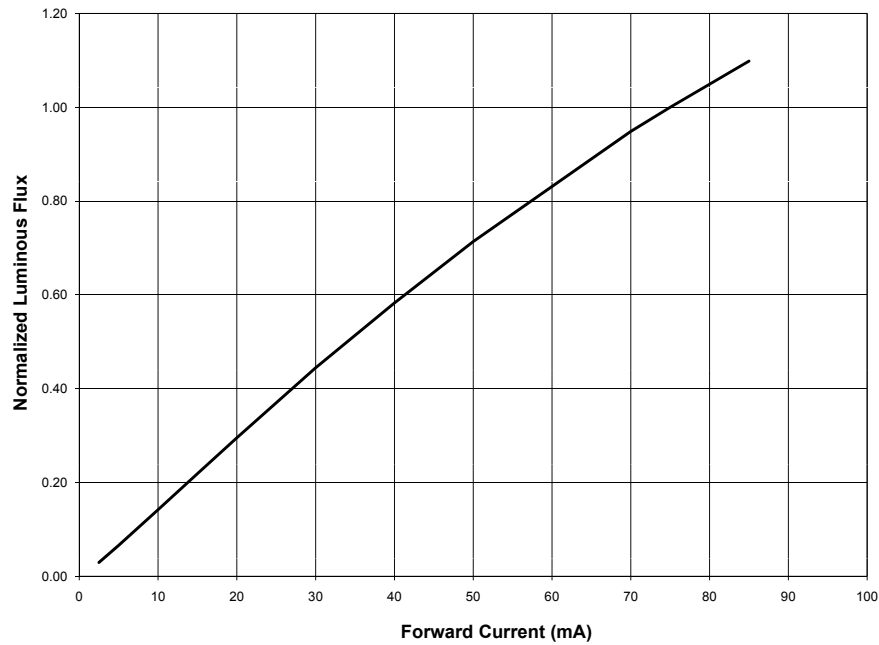

Figure 5. Typical relative luminous flux vs. forward current.

## SignalSure Red-Orange and Amber Luminous Flux vs. Junction Temperature

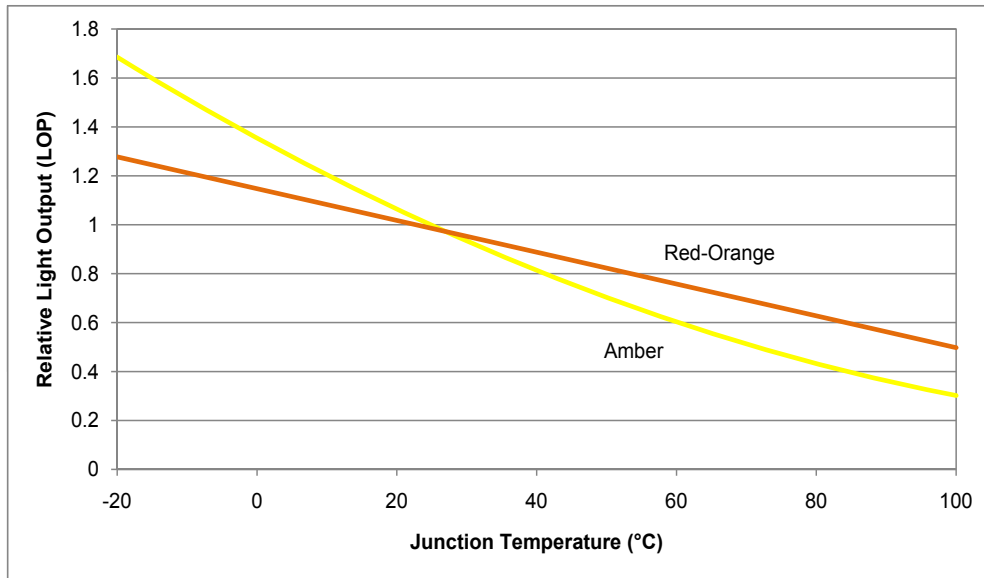

Figure 6. Relative light output vs. junction temperature normalized to junction temperature = 25°C.

## Typical Forward Current Characteristics, Junction Temperature = 25°C

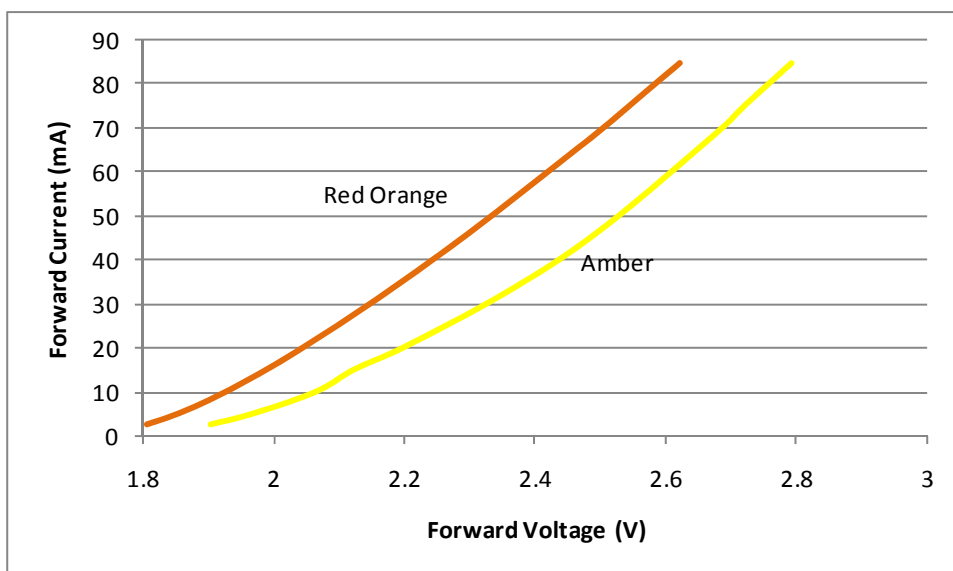

Figure 7. Forward current vs. forward voltage.

## Current Derating Curves

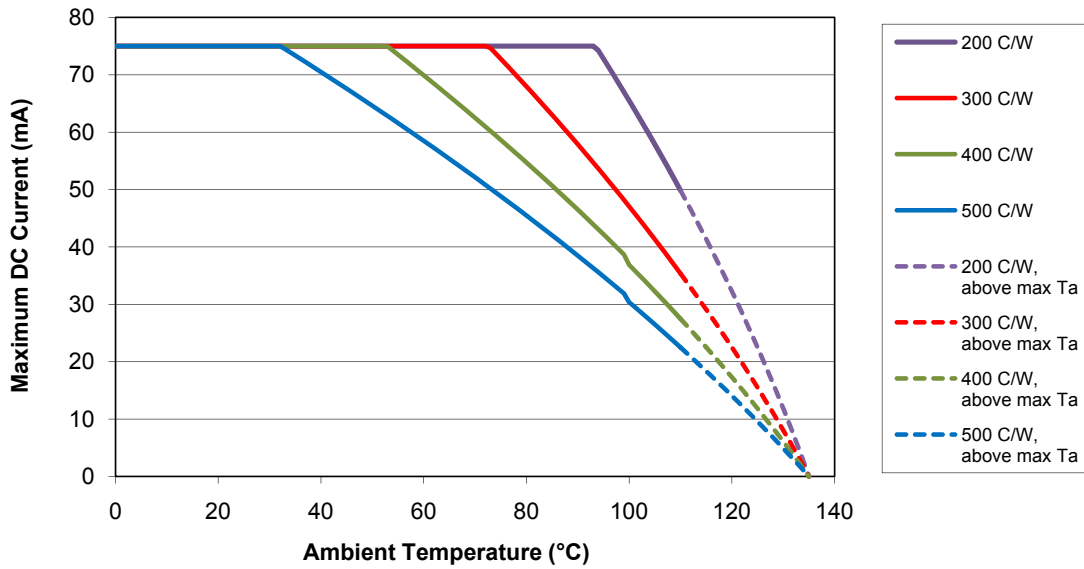

Figure 8. Maximum forward current vs. ambient temperature, based on  $T_j$  max 135°C.

## Typical Wavelength Characteristics, Junction Temperature = 25°C

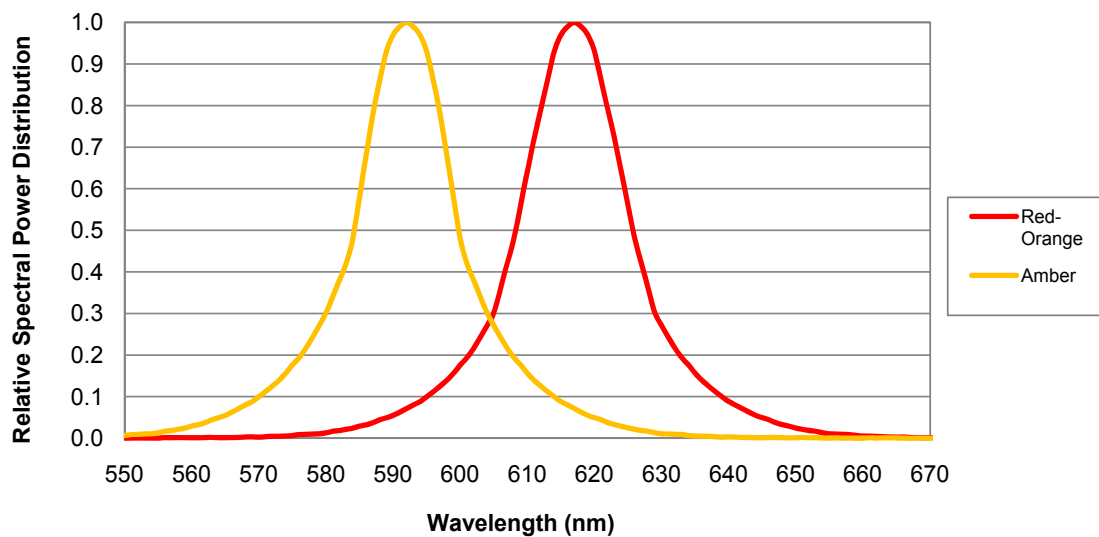

Figure 9. Relative intensity vs. wavelength.

# Binning Specification

## Luminous Flux Bin Definition

This section provides bin selection assistance for SignalSure. Product availability varies by color and other factors, and not all bin selection combinations are available. Contact your Philips Lumileds representative for further assistance.

**Table 9. Luminous Flux Bin Definition**

High Current Luminous Flux Bin					
Color	Applicable Product	Bin Code	Min Luminous Flux (lm) @ 75 mA	Max Luminous Flux (lm) @ 75 mA	Typical Luminous Intensity (cd) Reference
Red-Orange	SMD075-LO8I	D	6.10	7.30	2.40
		E	7.30	8.70	2.90
		F	8.70	10.40	3.40
		G	10.40	12.50	4.10
Amber	SMD075-LA8I	B	4.30	5.10	1.70
		C	5.10	6.10	2.00
		D	6.10	7.30	2.40
		E	7.30	8.70	2.90
		F	8.70	10.40	3.40

Note for Table 9:

- Tester error for brightness groups maintained at  $\pm 10\%$ . Parts are tested in Luminous Intensity.

## Bin Range Option Codes

Product availability varies by color and other factors, and not all bin selection combinations are available.

**Table 10.**

Flux Bin Codes	
Bin Range Option Codes	Bin Range
0	All bin above the Minimum
1	1 flux bin
2	2 flux bin
3	3 flux bin
4	4 flux bin
5	5 flux bin

Note for Table 10:

- Option codes indicate the inclusive range of flux bins allowed above the indicated requested bin.

## Color Bin Definition and Dominant Wavelength

**Table 11.**

Color	Color Code	Min (nm)	Max (nm)
Amber	1	588	590
	2	590	594
Red-Orange	3	613	618
	4	618	623
	5	623	628

Note for Table 11:

- Tester error for wavelength maintained at  $\pm 1$ nm.

## Forward Current ( $V_f$ ) Bin Definition

**Table 12. Forward Current ( $V_f$ ) Bin Definition**

High Current  $V_f$  Binning (75 mA)

$V_f$ Label	Min $V_f$ (V)	Max $V_f$ (V)
1	2.37	2.43
2	2.43	2.49
3	2.49	2.55
4	2.55	2.61
5	2.61	2.67
6	2.67	2.73
7	2.73	2.79
8	2.79	2.85
9	2.85	2.91
A	2.91	2.97
B	2.97	3.03
C	3.03	3.09

Note for Table 12:

- Tester error for  $V_f \pm 45$  mV @ 75 mA.

# Packing Information

SignalSure reel  $\phi$  180 mm = 2000 pieces/reel.

## SignalSure Pocket Tape Packaging

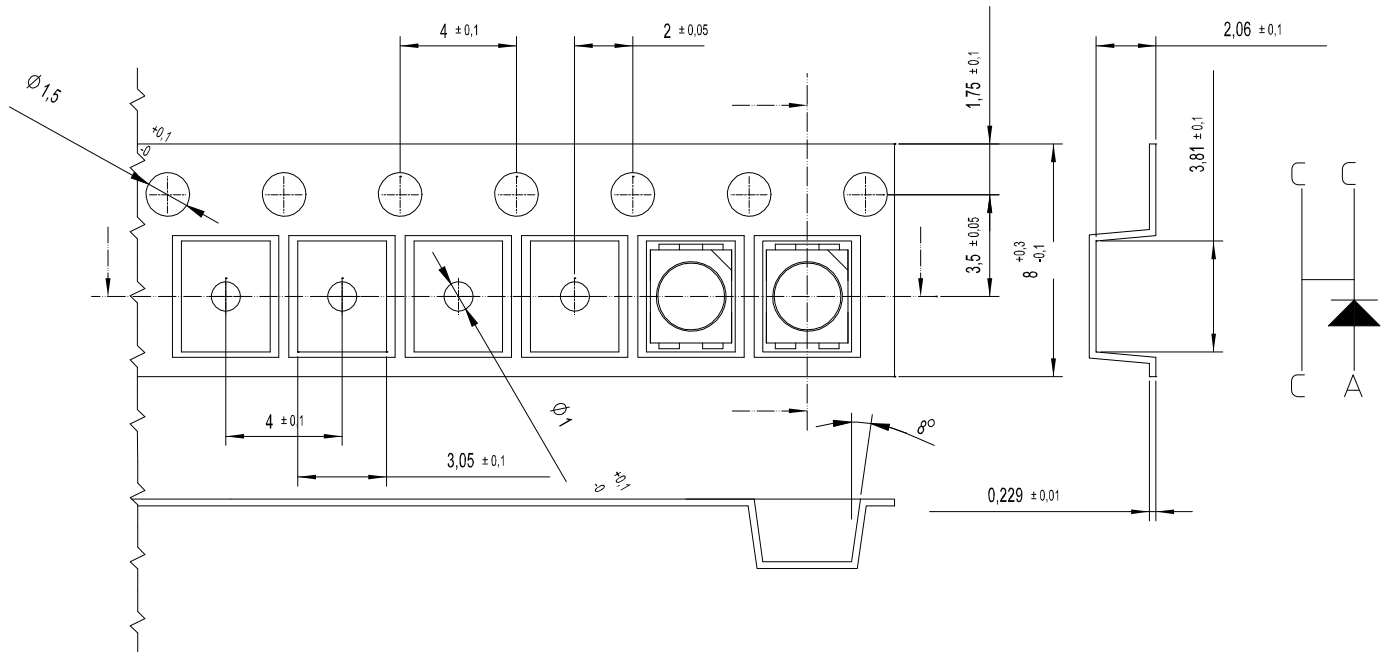

200 mm min. for  $\phi$ 180 reel.  
200 mm min. for  $\phi$ 330 reel.

480 mm min. for  $\phi$ 180 reel.  
960 mm min. for  $\phi$ 330 reel.

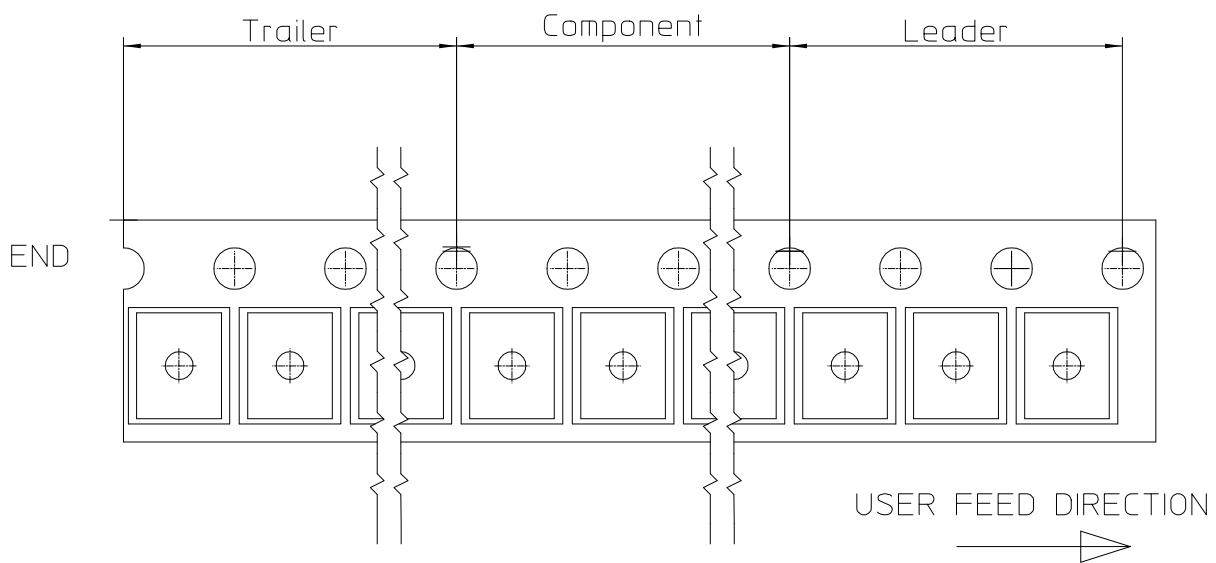

Figure 10. SignalSure pocket tape packaging.

# SignalSure Reel Packaging

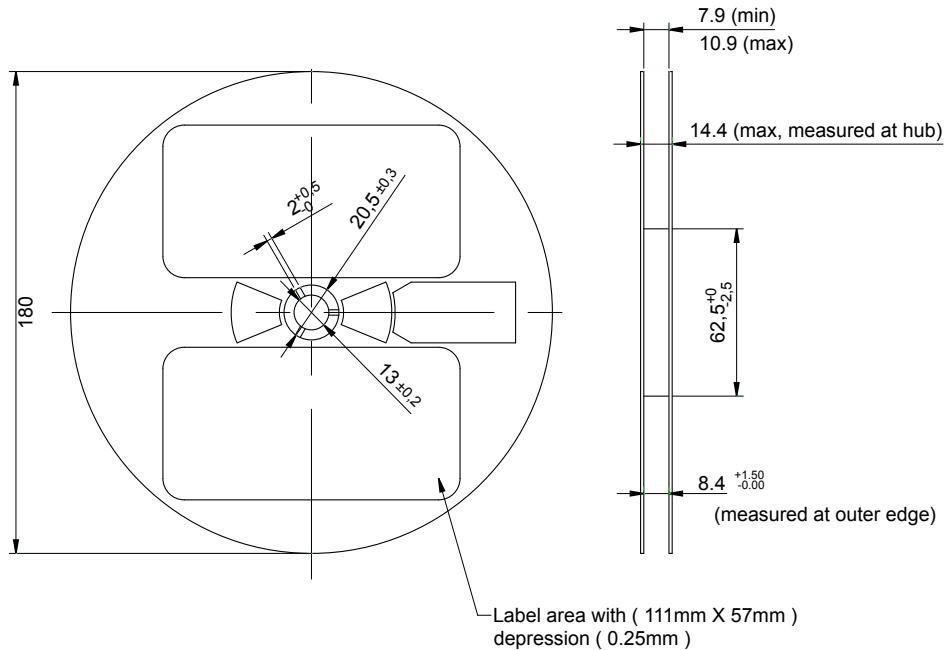

Figure 11. SignalSure reel packaging.

# Product Labeling Information

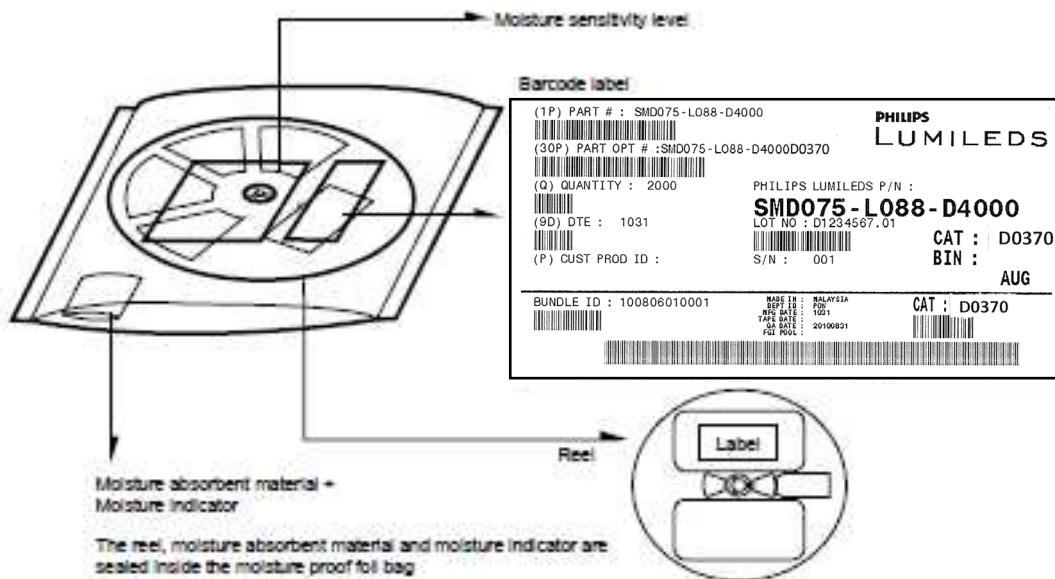

Figure 12. SignalSure labeling information.

## CAT Code Label

SignalSure is shipped in a moisture barrier bag (MBB). The CAT code label in the MBB indicates flux bin, color bin and  $V_f$ . For specific information please refer to example below and the preceding tables.

(1P) PART #: **SMD075-L088-D4000** **PHILIPS LUMILEDS**  
(30P) PART OPT#: **SMD075-L088-D4000D0370**  
(Q) QTY : **2000** LOT NO : D1234567.01 S/N : 001  
(9D) DTE : **1031** LUMILEDS LIGHTING P/N : **SMD075-L088-D4000**  
(P) CUST PROD ID : **CAT: D0370**  
(K) PO NO : **BIN: 70**  
**AUG**  
BUNDLE ID : **100806010001** MADE IN : MALAYSIA **CAT : D0370**  
DEPT ID : POW  
MFG DATE : 1031  
TAPE DATE :  
QA DATE : 20100831  
FGI POOL :

Indicates  
Flux Bin

Indicates  
Color Bin

Indicates  
 $V_f$

# Company Information

Philips Lumileds is a leading provider of LEDs for everyday lighting applications. The company's records for light output, efficacy and thermal management are direct results of the ongoing commitment to advancing solid-state lighting technology and enabling lighting solutions that are more environmentally friendly, help reduce CO<sub>2</sub> emissions and reduce the need for power plant expansion. Philips Lumileds LUXEON® LEDs are enabling never before possible applications in outdoor lighting, shop lighting, home lighting, consumer electronics, and automotive lighting.

Philips Lumileds is a fully integrated supplier, producing core LED material in all three base colors, (Red, Green, Blue) and white. Philips Lumileds has R&D centers in San Jose, California and in the Netherlands, and production capabilities in San Jose, Singapore and Penang, Malaysia. Founded in 1999, Philips Lumileds is the high flux LED technology leader and is dedicated to bridging the gap between solid-state technology and the lighting world. More information about the company's LUXEON LED products and solid-state lighting technologies can be found at [www.philipslumileds.com](http://www.philipslumileds.com).

©2012 Philips Lumileds Lighting Company. All rights reserved.  
Product specifications are subject to change without notice.  
LUXEON is a registered trademark of the Philips Lumileds  
Lighting Company in the United States and other countries.

**PHILIPS**  
**LUMILEDS**

[www.philipslumileds.com](http://www.philipslumileds.com)  
[www.philipslumileds.cn.com](http://www.philipslumileds.cn.com)