

HERMETIC SCHOTTKY RECTIFIER

1N6492

- Extremely Low V_F and I_R
- High Surge Capability
- Low Recovery Charge
- Low Profile TO-39 Hermetic Package
- High-Reliability Screening Options Available

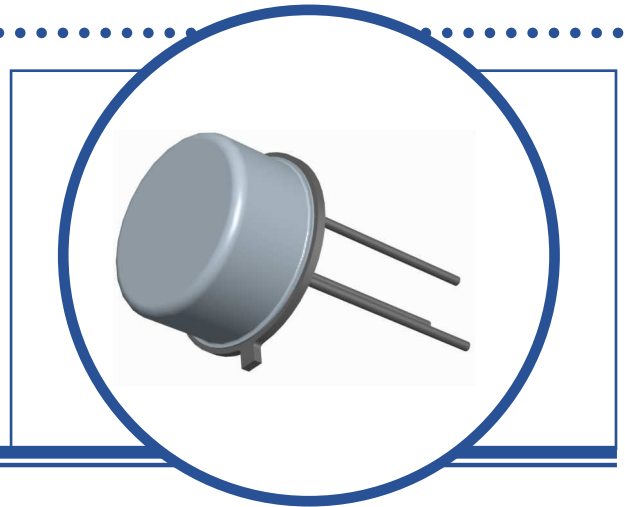

ABSOLUTE MAXIMUM RATINGS ($T_A = 25^\circ\text{C}$ unless otherwise stated)

| | | |
|-------------|--|---------------|
| V_{RRM} | Peak Repetitive Reverse Voltage | 45V |
| V_{RWM} | Working Peak Reverse Voltage | 45V |
| V_R | DC Blocking Voltage | 45V |
| V_{RSM} | Non-Repetitive Peak Reverse Voltage | 54V |
| $I_{F(av)}$ | Average Forward Current 50% Duty Cycle, $T_A = 25^\circ\text{C}$ | 1.2A |
| $I_{F(av)}$ | Average Forward Current 50% Duty Cycle, $T_{CASE} = 100^\circ\text{C}$ $T_{VRM} = 45\text{V}$ | 4.0A |
| I_{FSM} | Non-Repetitive Peak Surge Current 8.3ms, Half Sine Wave | 80.0A |
| T_J | Junction Temperature Range | -65 to +175°C |
| T_{stg} | Storage Temperature Range | -65 to +175°C |

THERMAL PROPERTIES

| Symbols | Parameters | Max. | Units |
|-----------------|---|------|-------|
| $R_{\theta JA}$ | Thermal Resistance, Junction To Ambient | 175 | °C/W |
| $R_{\theta JC}$ | Thermal Resistance, Junction To Case | 12 | °C/W |

Semelab Limited reserves the right to change test conditions, parameter limits and package dimensions without notice. Information furnished by Semelab is believed to be both accurate and reliable at the time of going to press. However Semelab assumes no responsibility for any errors or omissions discovered in its use. Semelab encourages customers to verify that datasheets are current before placing orders.

HERMETIC SCHOTTKY RECTIFIER 1N6492

ELECTRICAL CHARACTERISTICS (T_A = 25°C unless otherwise stated)

| Symbols | Parameters | Test Conditions | Min. | Typ. | Max. | Units |
|----------------|-------------------------|---|------|------|------|-------|
| I _R | Reverse Leakage Current | V _{RM} = 45V ⁽¹⁾ | | | 2 | mA |
| | | V _{RM} = 45V T _A = 125°C | | | 20 | |
| | | V _{RM} = 45V ⁽²⁾ T _A = 175°C | | | 200 | |
| | | V _{RM} = 45V T _A = -55°C | | | 20 | |
| V _F | Forward Voltage | I _{FM} = 8A (pk) ⁽¹⁾ | | | 0.92 | V |
| | | I _F = 4A (pk) | | | 0.68 | |
| | | I _F = 2A (pk) T _A = -55°C | | | 0.56 | |
| | | I _F = 1.0A (pk) | | | 0.63 | |

DYNAMIC CHARACTERISTICS

| | | | | | | |
|----------------|-------------|------------------------|--|--|-----|----|
| C _T | Capacitance | V _{RM} = 5.0V | | | 450 | pF |
|----------------|-------------|------------------------|--|--|-----|----|

Notes:

- (1) Pulse width = 400µSec, Duty Cycle 1%
- (2) By design, not a production test

MECHANICAL DATA

Dimensions in mm (inches)

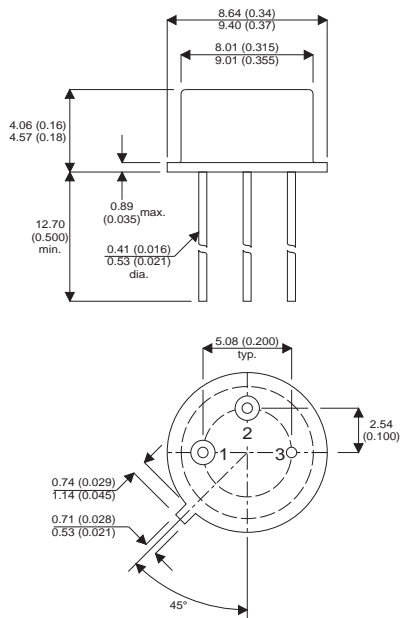

Low Profile TO-39 (TO-205AF) Underside View

Pin 1 - Anode

Pin 2 - N/C

Pin 3 / Case- Cathode

HERMETIC SCHOTTKY RECTIFIER

1N6492

SCREENING OPTIONS

Space Level (JQRS/ESA) and High Reliability options are available in accordance with the [High Reliability and Screening Options Handbook](#) available for download from the from the TT electronics Semelab web site.

ESA Quality Level Products are based on the testing procedures specified in the generic ESCC 5000 and in the corresponding part detail specifications.

Semelabs QR216 and QR217 processing specifications (JQRS), in conjunction with the companies ISO 9001:2000 approval present a viable alternative to the American MIL-PRF-19500 space level processing.

QR217 (Space Level Quality Conformance) is based on the quality conformance inspection requirements of MIL-PRF-19500 groups A (table V), B (table VIa), C (table VII) and also ESA / ESCC 5000 (chart F4) lot validation tests.

QR216 (Space Level Screening) is based on the screening requirements of MIL-PRF-19500 (table IV) and also ESA /ESCC 5000 (chart F3).

JQRS parts are processed to the device data sheet and screened to QR216 with conformance testing to Q217 groups A and B in accordance with MIL-STD-750 methods and procedures.

Additional conformance options are available, for example Pre-Cap Visual Inspection, Buy-Off Visit or Data Packs. These are chargeable and must be specified at the order stage (See Ordering Information). Minimum order quantities may apply.

Alternative or additional customer specific conformance or screening requirements would be considered. Contact Semelab sales with enquiries.

MARKING DETAILS

Screened parts are typically marked with specification number, serial number & week of seal.

Customer specific marking requirements can be arranged at time of order

ORDERING INFORMATION

Part number is built from part and screening level. The part number can be extended to include the additional options as shown below.

Type – See Electrical Stability Characteristics Table
Package Variant – See Mechanical Data
Screening Level – See Screening Options (ESA / JQRS)

Additional Options:

| | |
|--|-------------------|
| Customer Pre-Cap Visual Inspection | .CVP |
| Customer Buy-Off visit | .CVB |
| Data Pack | .DA |
| Solderability Samples | .SS |
| Scanning Electron Microscopy | .SEM |
| Radiography (X-ray) | .XRAY |
| Total Dose Radiation Test | .RAD |
| MIL-PRF-19500 (QR217) | |
| Group B charge | .GRPB |
| Group B destructive mechanical samples | .GBDM (12 pieces) |
| Group C charge | .GRPC |
| Group C destructive electrical samples | .GCDE (12 pieces) |
| Group C destructive mechanical samples | .GCDM (6 pieces) |
| ESA/ESCC | |
| Lot Validation Testing (subgroup 1) charge | .LVT1 |
| LVT1 destructive samples (environmental) | .L1DE (15 pieces) |
| LVT1 destructive samples (mechanical) | .L1DM (15 pieces) |
| Lot Validation Testing (subgroup 2) charge | .LVT2 |
| LVT2 endurance samples (electrical) | .L2D (15 pieces) |
| Lot Validation Testing (subgroup 3) charge | .LVT3 |
| LVT3 destructive samples (mechanical) | .L3D (5 pieces) |

Additional Option Notes:

- 1) All 'Additional Options' are chargeable and must be specified at order stage.
- 2) When Group B,C or LVT is required, additional electrical and mechanical destructive samples must be ordered
- 3) All destructive samples are marked the same as other production parts unless otherwise requested.

Example ordering information:

The following example is for the part with, JQRS screening, additional Group C conformance testing and a Data pack.

Part Numbers:

- 1N6492-JQRS (Include quantity for flight parts)
- 1N6492-JQRS.GRPC (chargeable conformance option)
- 1N6492-JQRS.GCDE (charge for destructive parts)
- 1N6492-JQRS.GCDM (charge for destructive parts)
- 1N6492-JQRS.DA (charge for Data pack)

Customers with any specific requirements (e.g. marking, package or screening) may be supplied with a similar alternative part number. Contact Semelab sales with all enquiries

High Reliability and Screening Options Handbook link: http://www.semelab.co.uk/pdf/misc/documents/hirel_and_screening_options.pdf