

**MECHANICAL DATA**

Dimensions in mm (inches)

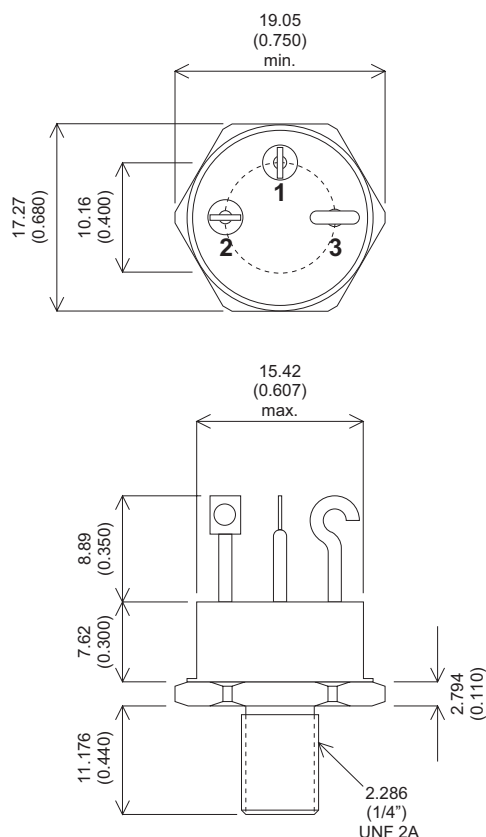

**TO-61 Metal Package.**

Pin 1 – Emitter      Pin 2 – Base      Case – Collector

**NPN SILICON TRANSISTOR**

- **Bipolar Power Transistor**
- **TO-61 Hermetic Package**
- **High Current Switching**
- **LF Large Signal Amplification**

**ABSOLUTE MAXIMUM RATINGS** ( $T_{case} = 25^{\circ}C$  unless otherwise stated)

$V_{CBO}$	Collector – Base Voltage	100V
$V_{CEO}$	Collector – Emitter Voltage	80V
$V_{EBO}$	Emitter – Base Voltage	8V
$I_C$	Continuous Collector Current	5A
$P_D$	Total Device Dissipation	85W
	Derate above 100°C	570 mW/°C
$T_{STG}, T_J$	Storage and Operating Junction Temperature Range	-65 to +175°C

Semelab Plc reserves the right to change test conditions, parameter limits and package dimensions without notice. Information furnished by Semelab is believed to be both accurate and reliable at the time of going to press. However Semelab assumes no responsibility for any errors or omissions discovered in its use. Semelab encourages customers to verify that datasheets are current before placing orders.

Parameter		Test Conditions	Min.	Typ.	Max.	Units
$I_{CBO}$	Collector-Base cut-off current $T_{case} = 150^{\circ}C$	$V_{CB} = 100V$ $I_E = 0$			10	mA
$I_{CEX}$	Collector-Emitter cut-off current	$V_{CB} = 100V$ $V_{BE} = -1V$			1	
$I_{EBO}$	Emitter-Base cut-off current	$V_{EB} = 8V$ $I_C = 0$			1	
$V_{(BR)CEO}^*$	Collector-Emitter Breakdown Voltage	$I_C = 100mA$ $I_B = 0$	80			V
$V_{(BR)EBO}^*$	Emitter-Base Breakdown Voltage	$I_B = 1mA$ $I_C = 0$	8			
$V_{(BR)CBO}^*$	Collector-Base Breakdown Voltage	$I_C = 1mA$ $I_E = 0$	100			
$h_{21E}$	Static Forward Current Transfer Ratio	$V_{CE} = 12V$ $I_C = 2A$	15		75	-
$V_{CEsat}$	Collector-Emitter Saturation Voltage	$I_C = 2A$ $I_B = 250mA$			2	V
$V_{BE}$	Base-Emitter Voltage	$V_{CE} = 12V$ $I_C = 2A$			3	
$f_T$	Transition Frequency (f=1MHz)	$V_{CE} = 30V$ $I_C = 300mA$	3			MHz
$R_{th(J-C)}$	Thermal Resistance (junction to case)				1.75	$^{\circ}C/W$

\* Pulse test  $t_p = 300\mu s$ ,  $\delta \leq 2\%$