

MECHANICAL DATA

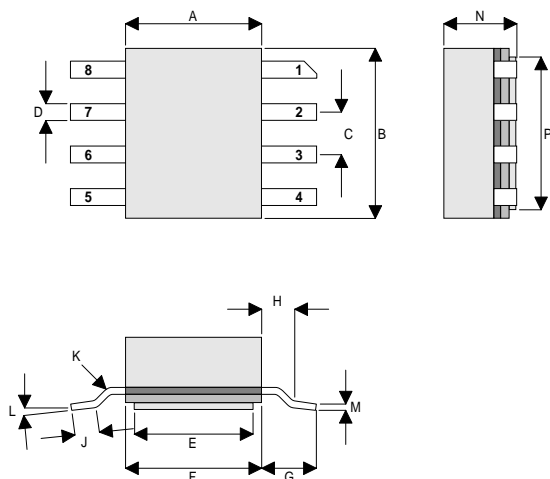

SO8 PACKAGE

PIN 1 – SOURCE                      PIN 5 – SOURCE  
 PIN 2 – DRAIN                      PIN 6 – GATE  
 PIN 3 – DRAIN                      PIN 7 – GATE  
 PIN 4 – SOURCE                      PIN 8 – SOURCE

Dim.	mm	Tol.	Inches	Tol.
A	4.06	±0.08	0.160	±0.003
B	5.08	±0.08	0.200	±0.003
C	1.27	±0.08	0.050	±0.003
D	0.51	±0.08	0.020	±0.003
E	3.56	±0.08	0.140	±0.003
F	4.06	±0.08	0.160	±0.003
G	1.65	±0.08	0.065	±0.003
H	0.76	+0.25 -0.00	0.030	+0.010 -0.000
J	0.51	Min.	0.020	Min.
	1.02	Max.	0.040	Max.
K	45°	Max.	45°	Max.
	0°	Min.	0°	Min.
L	7°	Max.	7°	Max.
	0°	Min.	0°	Min.
M	0.20	±0.08	0.008	±0.003
N	2.18	Max.	0.086	Max.
P	4.57	±0.08	0.180	±0.003

**GOLD METALLISED  
 MULTI-PURPOSE SILICON  
 DMOS RF FET  
 10W – 12.5V – 500MHz  
 SINGLE ENDED**

FEATURES

- SIMPLIFIED AMPLIFIER DESIGN
- SUITABLE FOR BROAD BAND APPLICATIONS
- VERY LOW  $C_{rss}$
- SIMPLE BIAS CIRCUITS
- LOW NOISE
- HIGH GAIN – 10 dB MINIMUM

APPLICATIONS

- HF/VHF/UHF COMMUNICATIONS  
 from 1 MHz to 1 GHz

ABSOLUTE MAXIMUM RATINGS ( $T_{case} = 25^{\circ}C$  unless otherwise stated)

$P_D$	Power Dissipation	30W
$BV_{DSS}$	Drain – Source Breakdown Voltage	40V
$BV_{GSS}$	Gate – Source Breakdown Voltage	±20V
$I_{D(sat)}$	Drain Current	10A
$T_{stg}$	Storage Temperature	-65 to 150°C
$T_j$	Maximum Operating Junction Temperature	200°C

Semelab Plc reserves the right to change test conditions, parameter limits and package dimensions without notice. Information furnished by Semelab is believed to be both accurate and reliable at the time of going to press. However Semelab assumes no responsibility for any errors or omissions discovered in its use. Semelab encourages customers to verify that datasheets are current before placing orders.

## ELECTRICAL CHARACTERISTICS (T<sub>case</sub> = 25°C unless otherwise stated)

Parameter	Test Conditions	Min.	Typ.	Max.	Unit
B <sub>V</sub> DSS Drain-Source Breakdown Voltage	V <sub>GS</sub> = 0      I <sub>D</sub> = 10mA	40			V
I <sub>D</sub> DSS Zero Gate Voltage Drain Current	V <sub>DS</sub> = 12.5V      V <sub>GS</sub> = 0			1	mA
I <sub>G</sub> DSS Gate Leakage Current	V <sub>GS</sub> = 20V      V <sub>DS</sub> = 0			1	μA
V <sub>GS(th)</sub> Gate Threshold Voltage*	I <sub>D</sub> = 10mA      V <sub>DS</sub> = V <sub>GS</sub>	1		7	V
g <sub>fs</sub> Forward Transconductance*	V <sub>DS</sub> = 10V      I <sub>D</sub> = 1A	0.8			S
G <sub>PS</sub> Common Source Power Gain	P <sub>O</sub> = 10W	10			dB
η Drain Efficiency	V <sub>DS</sub> = 12.5V      I <sub>DQ</sub> = 0.4A	50			%
VSWR Load Mismatch Tolerance	f = 500MHz	20:1			—
C <sub>iss</sub> Input Capacitance	V <sub>DS</sub> = 0V      V <sub>GS</sub> = -5V      f = 1MHz			60	pF
C <sub>oss</sub> Output Capacitance	V <sub>DS</sub> = 12.5V      V <sub>GS</sub> = 0      f = 1MHz			40	pF
C <sub>rss</sub> Reverse Transfer Capacitance	V <sub>DS</sub> = 12.5V      V <sub>GS</sub> = 0      f = 1MHz			4	pF

\* Pulse Test:    Pulse Duration = 300 μs , Duty Cycle ≤ 2%

## THERMAL DATA

R <sub>THj-case</sub>	Thermal Resistance Junction – Case	Max. 6°C / W
-----------------------	------------------------------------	--------------

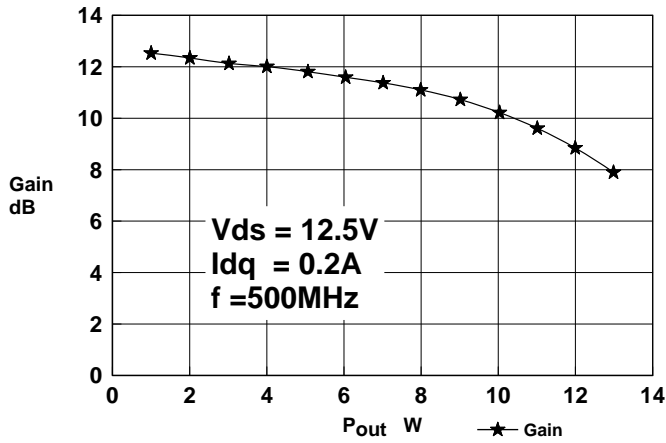

Figure 1 – Gain vs. Power Output.

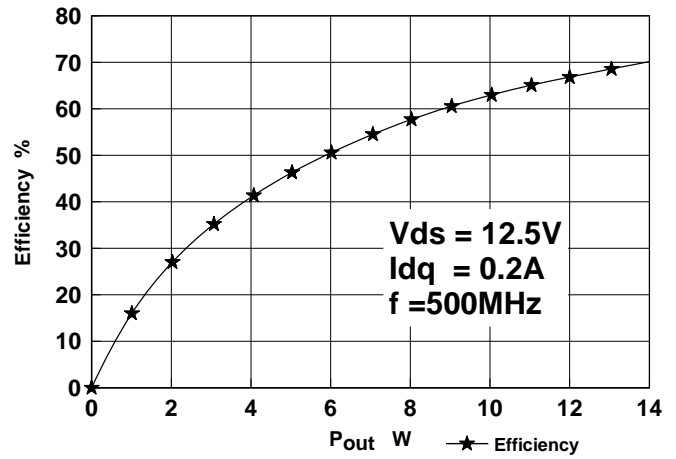

Figure 2 – Efficiency vs. Power Output.

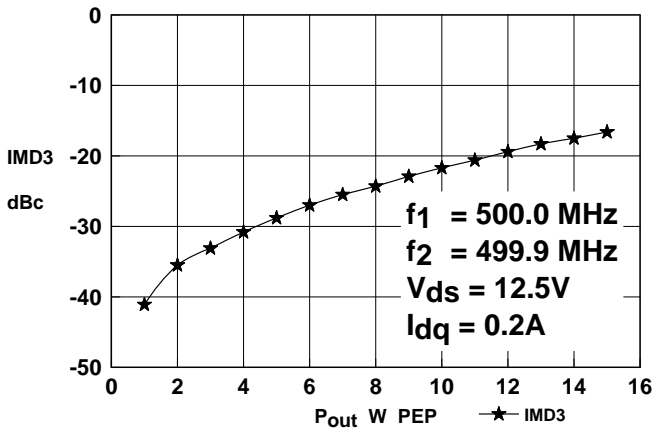

Figure 3 – IMD vs. Output Power.

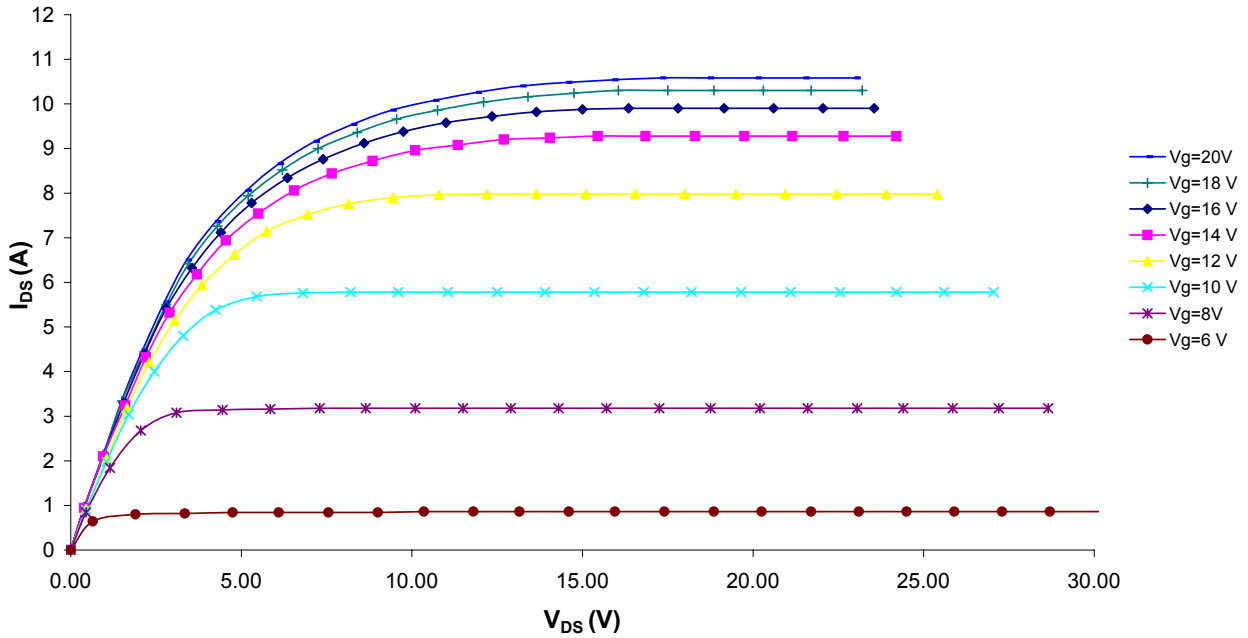

Figure 4 – Typical IV Characteristics.

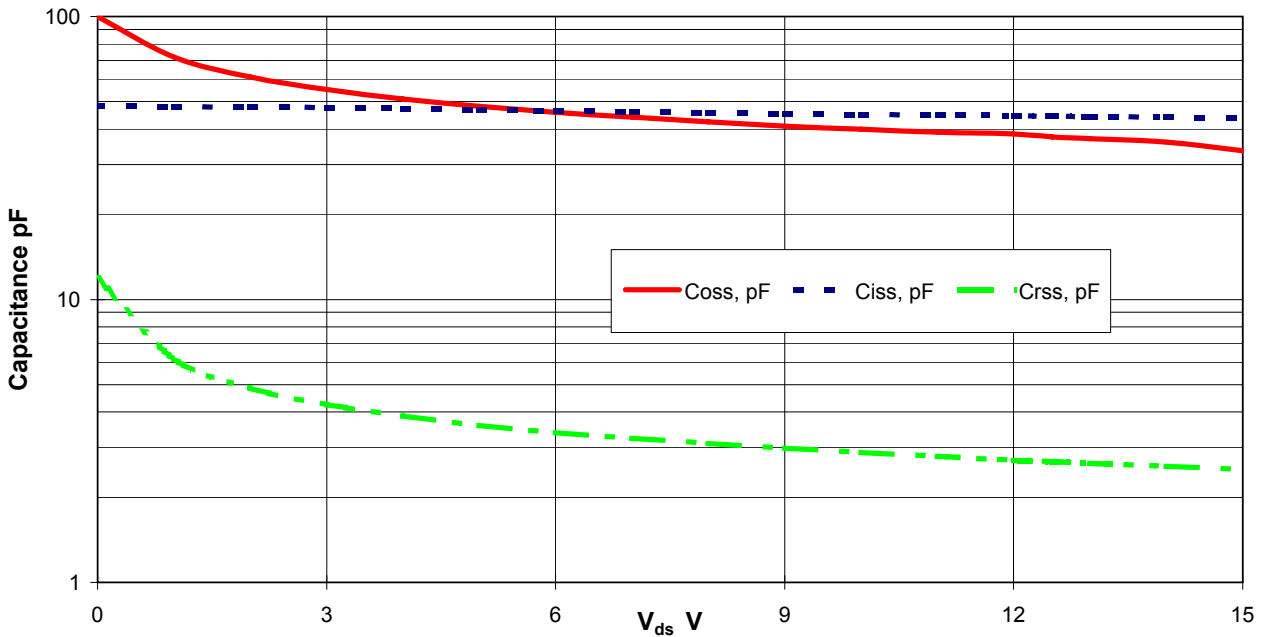
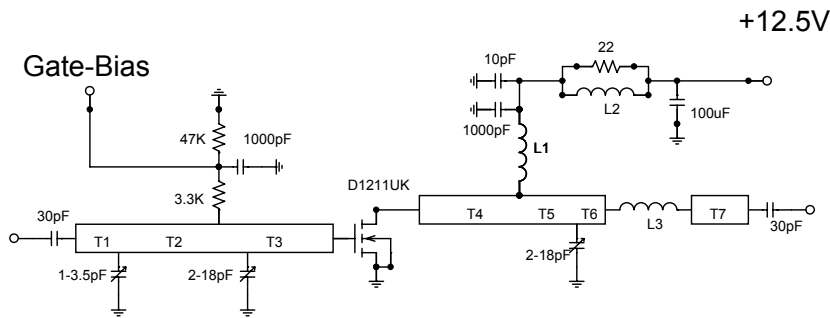

Figure 5 – Typical CV Characteristics.

Semelab Plc reserves the right to change test conditions, parameter limits and package dimensions without notice. Information furnished by Semelab is believed to be both accurate and reliable at the time of going to press. However Semelab assumes no responsibility for any errors or omissions discovered in its use. Semelab encourages customers to verify that datasheets are current before placing orders.



## D1211UK 500MHz TEST FIXTURE

Substrate 0.8mm PTFE/glass, Er=2.5

All microstrip lines W=1.5mm

T1 6mm

T2 35mm

T3 16mm

T4 11mm

T5 7mm

T6 7mm

T7 23mm

L1 6 turns 0.5mm dia enamelled copper wire, 4mm i.d.

L2 1.5 turns 0.5mm enamelled copper wire on 2 hole ferrite core

L3 1/16" dia wire hairpin loop 15mm long