

**MECHANICAL DATA**  
Dimensions in mm

**P-CHANNEL  
POWER MOSFET**

**POWER MOSFETS FOR  
AUDIO APPLICATIONS**

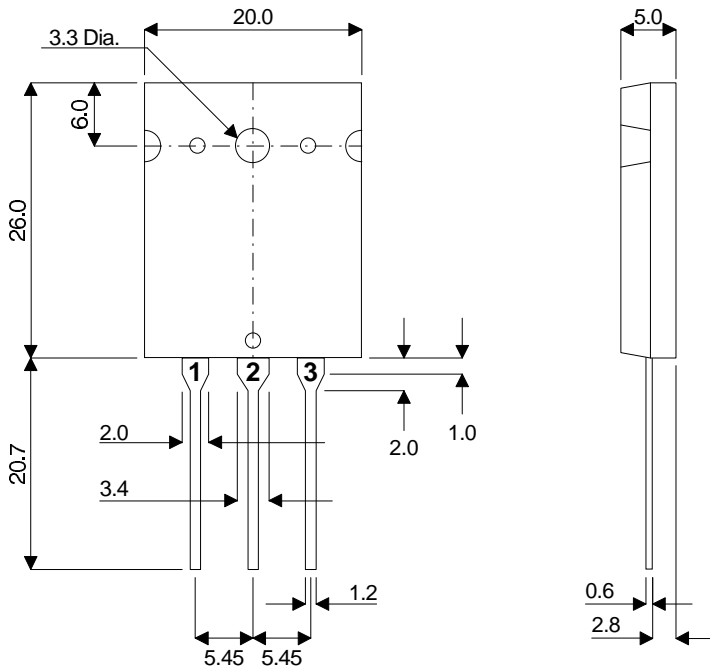

**TO-3PBL**

Pin 1 – Gate

Pin 2 – Source  
Case – Source

Pin 3 – Drain

**FEATURES**

- HIGH SPEED SWITCHING
- SEMEFAB DESIGNED AND DIFFUSED
- HIGH VOLTAGE (220V & 250V)
- HIGH ENERGY RATING
- ENHANCEMENT MODE
- INTEGRAL PROTECTION DIODES
- COMPLIMENTARY N-CHANNEL BUZ902DP & BUZ903DP

**ABSOLUTE MAXIMUM RATINGS**

( $T_{case} = 25^{\circ}C$  unless otherwise stated)

		<b>BUZ907DP</b>	<b>BUZ908DP</b>
$V_{DSX}$	Drain – Source Voltage	-220V	-250V
$V_{GSS}$	Gate – Source Voltage	$\pm 14V$	
$I_D$	Continuous Drain Current	-16A	
$I_{D(PK)}$	Body Drain Diode	-16A	
$P_D$	Total Power Dissipation @ $T_{case} = 25^{\circ}C$	250W	
$T_{stg}$	Storage Temperature Range	-55 to 150°C	
$T_j$	Maximum Operating Junction Temperature	150°C	
$R_{\theta JC}$	Thermal Resistance Junction – Case	0.5°C/W	

**STATIC CHARACTERISTICS** ( $T_{case} = 25^{\circ}C$  unless otherwise stated)

Characteristic	Test Conditions		Min.	Typ.	Max.	Unit
BV <sub>DSX</sub> Drain – Source Breakdown Voltage	V <sub>GS</sub> = 10V	BUZ907DP	-220			V
	I <sub>D</sub> = -10mA	BUZ908DP	-250			V
BV <sub>GSS</sub> Gate – Source Breakdown Voltage	V <sub>DS</sub> = 0	I <sub>G</sub> = ±100µA	±14			V
V <sub>GS(OFF)</sub> Gate – Source Cut-Off Voltage	V <sub>DS</sub> = -10V	I <sub>D</sub> = -100mA	-0.10		-1.5	V
V <sub>DS(SAT)</sub> * Drain – Source Saturation Voltage	V <sub>GD</sub> = 0	I <sub>D</sub> = -16A			-12	V
R <sub>DS(on)</sub> * Static – Source Resistance	V <sub>GS</sub> = -10	I <sub>D</sub> = -16A			0.75	Ω
I <sub>DSX</sub> Drain – Source Cut-Off Current	V <sub>GS</sub> = 10V	V <sub>DS</sub> = -220V BUZ907DP			-10	mA
		V <sub>DS</sub> = -250V BUZ908DP			-10	mA
y <sub>fs</sub> * Forward Transfer Admittance	V <sub>DS</sub> = -10V	I <sub>D</sub> = -3A	0.7		4	S

**DYNAMIC CHARACTERISTICS** ( $T_{case} = 25^{\circ}C$  unless otherwise stated)

Characteristic	Test Conditions		Min.	Typ.	Max.	Unit
C <sub>iSS</sub> Input Capacitance	V <sub>DS</sub> = -10V f = 1MHz			TBA		pF
C <sub>oss</sub> Output Capacitance				TBA		
C <sub>rSS</sub> Reverse Transfer Capacitance				TBA		
t <sub>on</sub> Turn-on Time	V <sub>DS</sub> = -20V I <sub>D</sub> = -5A			TBA		ns
t <sub>off</sub> Turn-off Time				TBA		

\* Pulse Test: Pulse Width = 300µs , Duty Cycle ≤ 2%.

