

MECHANICAL DATA

Dimensions in mm (inches)

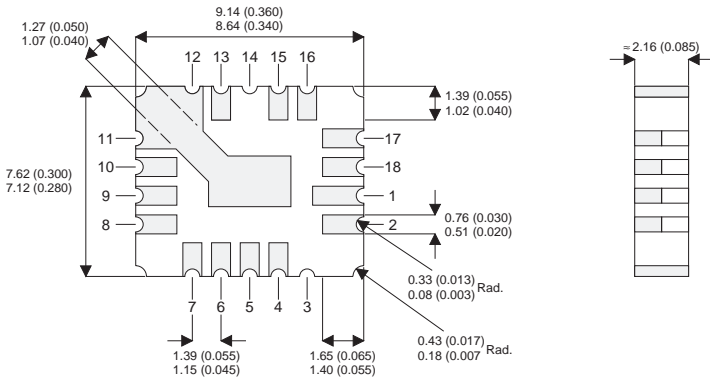

LCC4

MOSFET	TRANSISTOR	PINS
GATE	BASE	4,5
DRAIN	COLLECTOR	1,2,15,16,17,18
SOURCE	EMITTER	6,7,8,9,10,11,12,13

**P-CHANNEL
POWER MOSFET**

V_{DSS}	-100V
$I_{D(cont)}$	-2.2A
$R_{DS(on)}$	1.2Ω

FEATURES

- SURFACE MOUNT
- SMALL FOOTPRINT
- HERMETICALLY SEALED
- DYNAMIC dv/dt RATING
- AVALANCHE ENERGY RATING
- SIMPLE DRIVE REQUIREMENTS
- LIGHT WEIGHT

ABSOLUTE MAXIMUM RATINGS ($T_{case} = 25^{\circ}C$ unless otherwise stated)

V_{GS}	Gate – Source Voltage	$\pm 20V$
I_D	Continuous Drain Current @ $T_{case} = 25^{\circ}C$	- 2.2A
I_D	Continuous Drain Current @ $T_{case} = 100^{\circ}C$	- 1.4A
I_{DM}	Pulsed Drain Current	- 8.8A
P_D	Power Dissipation @ $T_{case} = 25^{\circ}C$	11W
	Linear Derating Factor	0.090W/ $^{\circ}C$
E_{AS}	Single Pulse Avalanche Energy ²	87mJ
dv/dt	Peak Diode Recovery ³	- 5.5V/ns
T_J, T_{stg}	Operating and Storage Temperature Range	- 55 to +150 $^{\circ}C$
	Surface Temperature (for 5 sec).	300 $^{\circ}C$

ELECTRICAL CHARACTERISTICS ($T_{\text{case}} = 25^{\circ}\text{C}$ unless otherwise stated)

Parameter	Test Conditions	Min.	Typ.	Max.	Unit
STATIC ELECTRICAL RATINGS					
BV_{DSS}	Drain – Source Breakdown Voltage	$V_{\text{GS}} = 0$ $I_{\text{D}} = -1\text{mA}$	-100		V
$\frac{\Delta BV_{\text{DSS}}}{\Delta T_{\text{J}}}$	Temperature Coefficient of Breakdown Voltage	Reference to 25°C $I_{\text{D}} = -1\text{mA}$		-0.10	$\text{V}/^{\circ}\text{C}$
$R_{\text{DS(on)}}$	Static Drain – Source On–State Resistance ¹	$V_{\text{GS}} = -10\text{V}$ $I_{\text{D}} = -1.4\text{A}$		1.2	Ω
		$V_{\text{GS}} = -10\text{V}$ $I_{\text{D}} = -2.2\text{A}$		1.38	
$V_{\text{GS(th)}}$	Gate Threshold Voltage	$V_{\text{DS}} = V_{\text{GS}}$ $I_{\text{D}} = -250\mu\text{A}$	-2	-4	V
g_{fs}	Forward Transconductance ¹	$V_{\text{DS}} \geq -15\text{V}$ $I_{\text{DS}} = -1.4\text{A}$	0.8		$\text{S} (\bar{\cup})$
I_{DSS}	Zero Gate Voltage Drain Current	$V_{\text{GS}} = 0$ $V_{\text{DS}} = 0.8BV_{\text{DSS}}$ $T_{\text{J}} = 125^{\circ}\text{C}$		-25	μA
				-250	
I_{GSS}	Forward Gate – Source Leakage	$V_{\text{GS}} = -20\text{V}$		-100	nA
I_{GSS}	Reverse Gate – Source Leakage	$V_{\text{GS}} = 20\text{V}$		100	
DYNAMIC CHARACTERISTICS					
C_{iss}	Input Capacitance	$V_{\text{GS}} = 0$		200	pF
C_{oss}	Output Capacitance	$V_{\text{DS}} = -25\text{V}$		85	
C_{rss}	Reverse Transfer Capacitance	$f = 1\text{MHz}$		30	
Q_{g}	Total Gate Charge	$V_{\text{GS}} = -10\text{V}$	4.0	9.8	nC
Q_{gs}	Gate – Source Charge	$I_{\text{D}} = -2.2\text{A}$	0.8	1.8	
Q_{gd}	Gate – Drain (“Miller”) Charge	$V_{\text{DS}} = 0.5BV_{\text{DSS}}$	1.9	4.3	
$t_{\text{d(on)}}$	Turn–On Delay Time	$V_{\text{DD}} = -50\text{V}$ $I_{\text{D}} = -2.2\text{A}$ $R_{\text{G}} = 7.5\Omega$		30	ns
t_{r}	Rise Time			60	
$t_{\text{d(off)}}$	Turn–Off Delay Time			40	
t_{f}	Fall Time			40	
SOURCE – DRAIN DIODE CHARACTERISTICS					
I_{S}	Continuous Source Current			-2.2	A
I_{SM}	Pulse Source Current ²			-8.8	
V_{SD}	Diode Forward Voltage ¹	$I_{\text{S}} = -2.2\text{A}$ $T_{\text{J}} = 25^{\circ}\text{C}$ $V_{\text{GS}} = 0$		-5.5	V
t_{rr}	Reverse Recovery Time	$I_{\text{F}} = -2.2\text{A}$ $T_{\text{J}} = 25^{\circ}\text{C}$		200	ns
Q_{rr}	Reverse Recovery Charge ¹	$d_{\text{i}} / d_{\text{t}} \leq -100\text{A}/\mu\text{s}$ $V_{\text{DD}} \leq -50\text{V}$		9.0	μC
t_{on}	Forward Turn–On Time		Negligible		
PACKAGE CHARACTERISTICS					
L_{D}	Internal Drain Inductance (measured from 6mm down drain lead to centre of die)		1.8		nH
L_{S}	Internal Source Inductance (from 6mm down source lead to source bond pad)		4.3		
THERMAL CHARACTERISTICS					
$R_{\theta\text{JC}}$	Thermal Resistance Junction – Case			11	$^{\circ}\text{C}/\text{W}$
$R_{\theta\text{JPC}}$	Thermal Resistance Junction – PC Board			27	

Notes

- 1) Pulse Test: Pulse Width $\leq 300\text{ms}$, $\delta \leq 2\%$
- 2) Repetitive Rating – Pulse width limited by maximum junction temperature.