

Mechanical Data
Dimensions in mm (inches)

MULTI-CHIP ARRAY

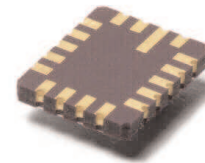

Case Style LCC6
Underside View

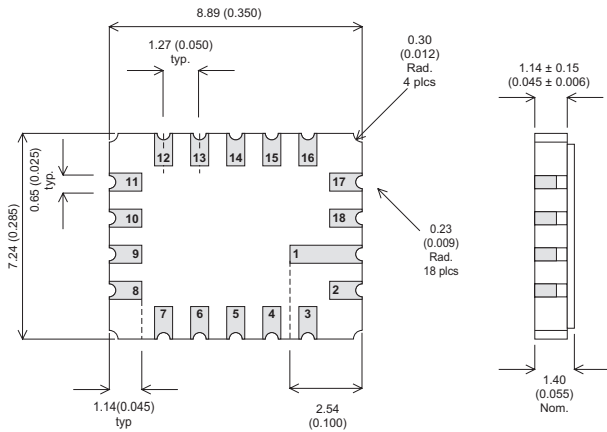
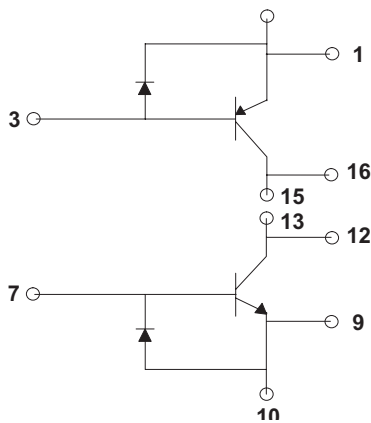

Circuit Diagram

FEATURES

- Silicon NPN & PNP Epitaxial Transistors
- Silicon Schottky Diode
- Hermetic Ceramic Surface Mount Package
- Small Size, Low Weight
- High Reliability
- Various Screening Options

ABSOLUTE MAXIMUM RATINGS

P_D	Total Power Dissipation @ $T_A = 25^\circ C$ Derate above $25^\circ C$	1.15W 11.5mW/ $^\circ C$
T_A	Operating Temperature Range	-55 to +125 $^\circ C$
T_{STG}	Storage Temperature Range	-55 to +150 $^\circ C$
T_{SOL}	Soldering Temperature @ $\Delta t = 10$ secs	230 $^\circ C$
$R_{\theta JA}$	Thermal Resistance Junction to Ambient	87 $^\circ C/w$

Semelab Plc reserves the right to change test conditions, parameter limits and package dimensions without notice. Information furnished by Semelab is believed to be both accurate and reliable at the time of going to press. However Semelab assumes no responsibility for any errors or omissions discovered in its use. Semelab encourages customers to verify that datasheets are current before placing orders.

ELECTRICAL CHARACTERISTICS ($T_A = 25^\circ\text{C}$ unless otherwise stated)

PNP TRANSISTOR

Parameter	Test Conditions	Min.	Typ.	Max.	Unit
$V_{(BR)CBO}^*$ Collector – Base Breakdown Voltage	$I_C = 10\mu\text{A}$ $I_E = 0$	- 12			V
$V_{(BR)CEO}$ Collector – Emitter Breakdown Voltage	$I_C = 10\text{mA}$ $I_B = 0$	- 12			
$V_{(BR)EBO}$ Emitter – Base Breakdown Voltage	$I_E = 10\mu\text{A}$ $I_C = 0$	- 4			
I_{CBO} Collector Cut-off Current	$V_{CB} = -6\text{V}$ $T_{amb} = 125^\circ\text{C}$			- 10	nA
I_{CES} Collector Cut-off Current	$V_{BE} = 0$ $V_{CE} = -6\text{V}$			- 80	
$V_{CE(sat)}$ Collector – Emitter Saturation Voltage	$I_C = -10\text{mA}$ $I_B = -1\text{mA}$			-0.15	V
	$I_C = -30\text{mA}$ $I_B = -3\text{mA}$			-0.20	
	$I_C = -100\text{mA}$ $I_B = -10\text{mA}$			- 0.50	
$V_{BE(sat)}$ Base – Emitter On Voltage	$I_C = -10\text{mA}$ $I_B = -1\text{mA}$	-0.78		-0.98	V
	$I_C = -30\text{mA}$ $I_B = -3\text{mA}$	-0.85		-1.2.	
	$I_C = -100\text{mA}$ $I_B = -10\text{mA}$			-1.7	
h_{FE} DC Current Gain	$I_C = -10\text{mA}$ $V_{CE} = -0.3\text{V}$	30			—
	$I_C = -30\text{mA}$ $V_{CE} = -0.5\text{V}$	40		150	
	$I_C = -100\text{mA}$ $V_{CE} = -1\text{V}$	25			
	$I_C = -30\text{mA}$ $V_{CE} = -0.5\text{V}$ $T_{amb} = 125^\circ\text{C}$	17			
f_T Current Gain Bandwidth Product	$V_{CE} = -10\text{V}$ $f = 100\text{MHz}$ $I_C = -30\text{mA}$	400			MHz
C_{ebo} Emitter – Base – Capacitance	$V_{EB} = -5\text{V}$ $I_C = 0$ $f = 1\text{MHz}$			6	pF
C_{cbo} Collector – Base – Capacitance	$V_{CB} = -5\text{V}$ $I_C = 0$ $f = 1\text{MHz}$			6	pF
t_{on} Turn on Time	$I_C = -30\text{mA}$ $V_{CE} = -2\text{V}$ $I_{B2} = -1.5\text{mA}$			60	ns
t_{off} Turn off Time	$I_C = -30\text{mA}$ $V_{CE} = -2\text{V}$ $I_{B1} = I_{B2} = -1.5\text{mA}$			9	ns

* Pulse Test: $t_p \leq 300\mu\text{s}$, $\delta \leq 2\%$.

ELECTRICAL CHARACTERISTICS ($T_A = 25^\circ\text{C}$ unless otherwise stated)

NPN TRANSISTOR

Parameter	Test Conditions	Min.	Typ.	Max.	Unit
$V_{(BR)CEO^*}$ Collector – Emitter Breakdown Voltage	$I_C = 10\text{mA}$	15			V
$V_{(BR)CBO}$ Collector – Base Breakdown Voltage	$I_C = 10\mu\text{A}$	40			V
$V_{(BR)EBO}$ Emitter – Base Breakdown Voltage	$I_E = 10\mu\text{A}$	4.5			V
I_{CES} Collector – Emitter Cut-off Current	$V_{CE} = 20\text{V}$			0.40	μA
	$V_{CE} = 10\text{V}$			0.30	
I_{CBO} Collector – Base Cut-off Current	$V_{CB} = 20\text{V}$			0.20	μA
		$T_A = +150^\circ\text{C}$		30	
I_{EBO} Emitter – Base Cut-off Current	$V_{EB} = 4\text{V}$			0.25	μA
$V_{CE(sat)}$ Collector – Emitter Saturation Voltage	$I_C = 10\text{mA}$ $I_B = 1\text{mA}$	$T_A = +150^\circ\text{C}$		0.20	V
				0.30	
		$I_C = 30\text{mA}$ $I_B = 3\text{mA}$		0.25	
	$I_C = 100\text{mA}$ $I_B = 10\text{mA}$			0.43	
$V_{BE(sat)}$ Base – Emitter Saturation Voltage	$I_C = 10\text{mA}$ $I_B = 1\text{mA}$	$T_A = +25^\circ\text{C}$	0.70	0.85	V
		$T_A = +150^\circ\text{C}$	0.59		
		$T_A = -55^\circ\text{C}$		1.02	
	$I_C = 30\text{mA}$ $I_B = 3\text{mA}$		0.90		
	$I_C = 100\text{mA}$ $I_B = 10\text{mA}$		1.20		
h_{FE^*} Current Gain	$I_C = 10\text{mA}$	$V_{CE} = 0.35\text{V}$	40	120	—
		$V_{CE} = 0.40\text{V}$	30	120	
	$V_{CE} = 1\text{V}$	$T_A = -55^\circ\text{C}$	40	120	
			20		
$ h_{fe} $ Magnitude of h_{fe}	$I_C = 10\text{mA}$ $f = 100\text{MHz}$	$V_{CE} = 10\text{V}$	5	10	—
C_{ob} Output Capacitance	$V_{CB} = 5\text{V}$ $I_E = 0$ $f = 100\text{kHz to } 1\text{MHz}$			4	pF
C_{ib} Input Capacitance	$V_{EB} = 0.5\text{V}$ $I_C = 0$ $f = 100\text{kHz to } 1\text{MHz}$			5	
t_s Storage Time	$I_C = 10\text{mA}$ $I_{B1} = -I_{B2} = 10\text{mA}$			13	ns
t_{on} Turn-On Time	$I_C = 10\text{mA}$			12	ns
t_{off} Turn-Off Time	$I_{B1} = 3\text{mA}$ $I_{B2} = -1.5\text{mA}$			18	

* Pulse Test: $t_p \leq 300\mu\text{s}$, $\delta \leq 2\%$.

Semelab Plc reserves the right to change test conditions, parameter limits and package dimensions without notice. Information furnished by Semelab is believed to be both accurate and reliable at the time of going to press. However Semelab assumes no responsibility for any errors or omissions discovered in its use. Semelab encourages customers to verify that datasheets are current before placing orders.

ELECTRICAL CHARACTERISTICS ($T_A = 25^\circ\text{C}$ unless otherwise stated)
SCHOTTKY DIODE

Parameter	Test Conditions	Min.	Typ.	Max.	Unit
I_R^* Reverse Current	$T_{amb} = 25^\circ\text{C}$ $V_R = 50\text{V}$			0.2	μA
V_F^* Forward Voltage	$T_{amb} = 25^\circ\text{C}$ $I_F = 1\text{mA}$			0.41	V
	$T_{amb} = 25^\circ\text{C}$ $I_F = 15\text{mA}$			1	
$V_{(BR)}$ Breakdown Voltage	$T_{amb} = 25^\circ\text{C}$ $I_R = 10\mu\text{A}$	70			V
C Capacitance	$T_{amb} = 25^\circ\text{C}$ $V_R = 0\text{V}$ $f = 1\text{MHz}$			2	pF
t Effective Minority Carrier Lifetime	$T_{amb} = 25^\circ\text{C}$ $I_F = 5\text{mA}$			100	ps

* Pulse test $\leq 300\mu\text{s}$, $\delta \leq 2\%$